

Client:

Customer Ref.:

Date:

Delivery desired date:

**01. INTRODUCTION**

**Chain Dimensions**

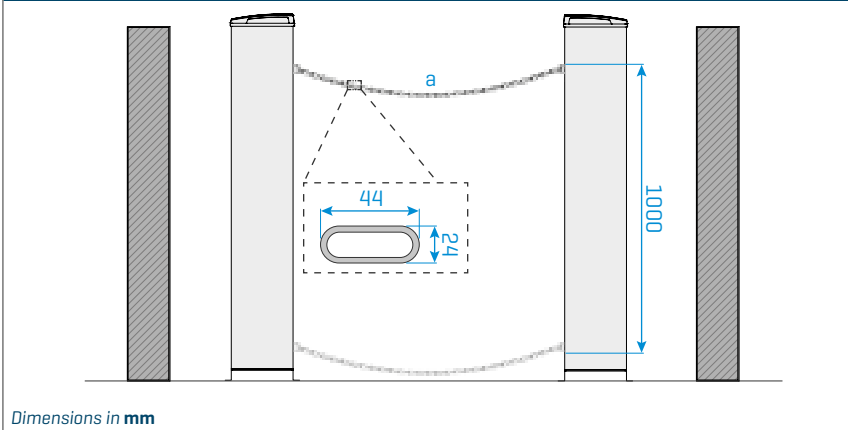

**Column Dimensions**

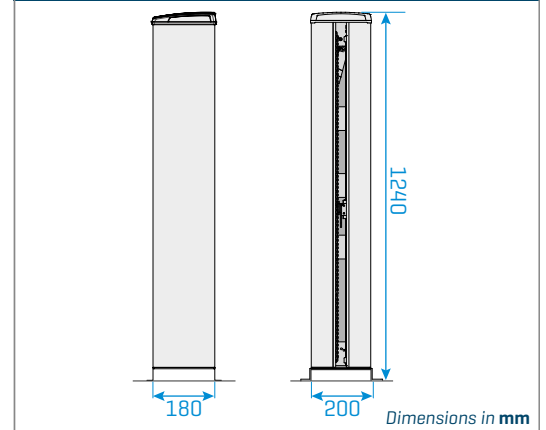

**Site Dimensions**

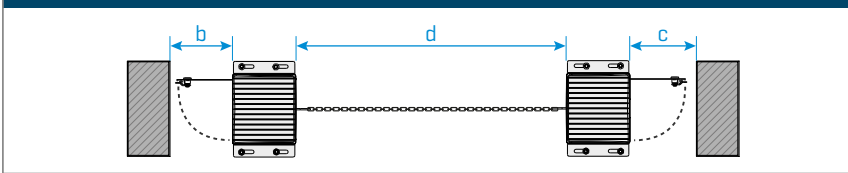

**Subtitle:**

- a - **Chain Weight:** maximum weight **20kg**;
- b - **Free space on the door side:** minimum **200mm**;
- c - **Free space on the door side:** minimum **200mm**;
- d - **Passageway**

**02. CHAIN**

**MATERIAL**

- Plastic (Standard)
- Iron



**LENGTH**

- 8 Meters (Standard)
- Meters

Please indicate if you require another length



**SPACE BETWEEN COLUMNS**

Meters



**03. EXTRAS**

**CHLCCCE** floor channel

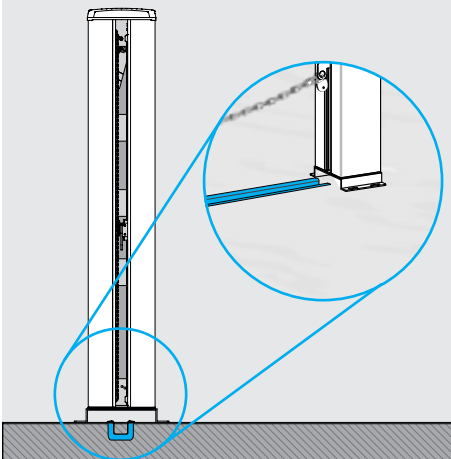

**CHLCCS** floor channel

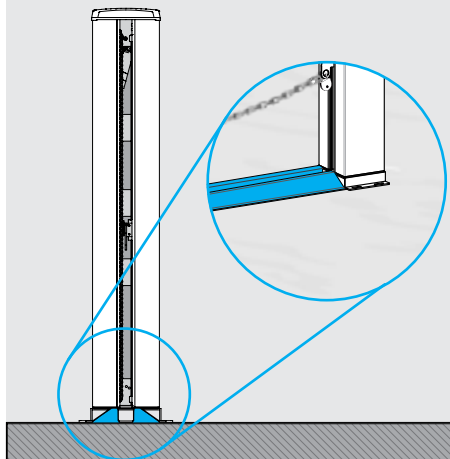

**2.2AH+CX50** Battery Kit

Magnetic loop **MD150**

**FALK**

Indicate the quantity you want

