

Client:

Réf. client :

Date:

Date désirée pour la livraison:

01. ENDROIT D'INSTALLATION

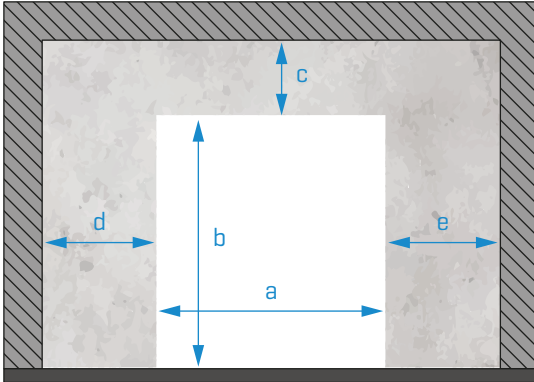

Quantité

Dimensions de l'endroit (mm):



REPLIR
OBLIGATOIREMENT

a

b

c

d

e

Couleur PVC:



5013



6026



1003



7037



9016



5002



3002



1015



7038



5010



5015



2004



9005



7035



7016

Autre:

Dispositifs supplémentaires:

MPR020

Kit tunnel

UPS (prix sur demande)

Télécommandes

Radars

Boucle magnétique

Modèle

Toutes les portes sont laquées en RAL9010 texturé.

Si vous souhaitez une autre couleur ou une autre finition, veuillez le mentionner ici:

INOX 304

INOX 316

Sans bande transparente

Cochez si vous **ne voulez pas** de bande transparente

Autres options:

OBSERVATIONS:

[DANS CE CHAMP, VOUS DEVEZ DÉCRIRE TOUT CE QUE VOUS PENSEZ QUI EST PERTINENT POUR LA PRODUCTION]

POSITION DU MOTEUR ET DE LA CENTRALE:

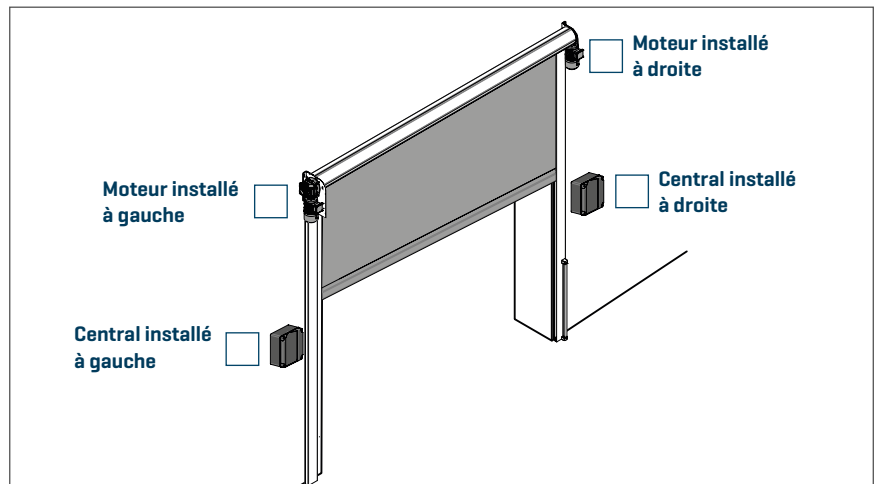

[DANS CE CHAMP, VOUS DEVEZ CONCEVOIR TOUT CE QUE VOUS PENSEZ QUI EST PERTINENT POUR LA PRODUCTION]

02. DESSIN TECHNIQUE [KIT NORMAL]

Dimensions en mm

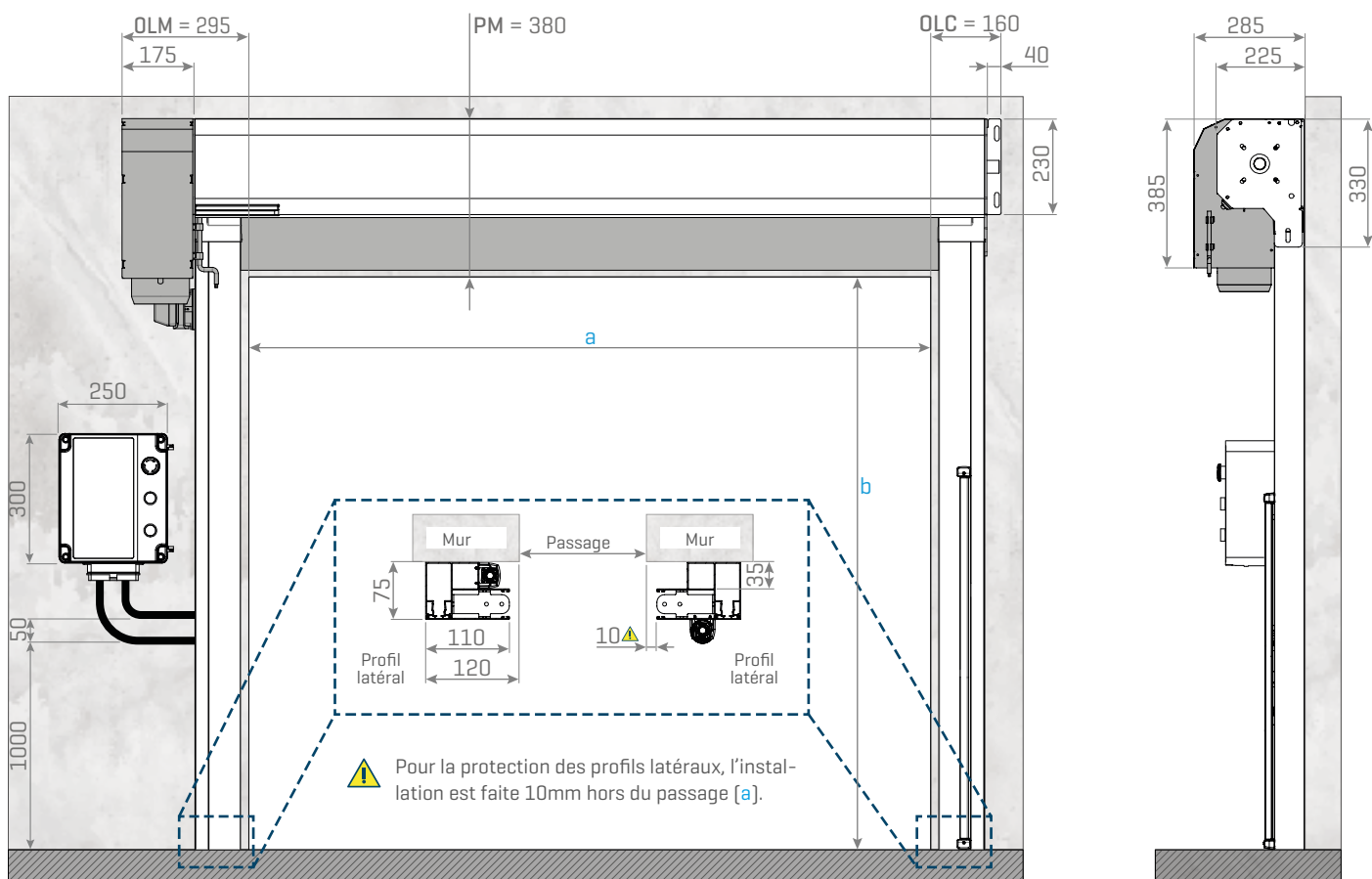

Légende: OLM - Écoinçon côté moteur; OLC - Ecoinçon côté opposé; PM - Linteau minimale

03. DESSIN TECHNIQUE [KIT TUNNEL]

Dimensions en mm

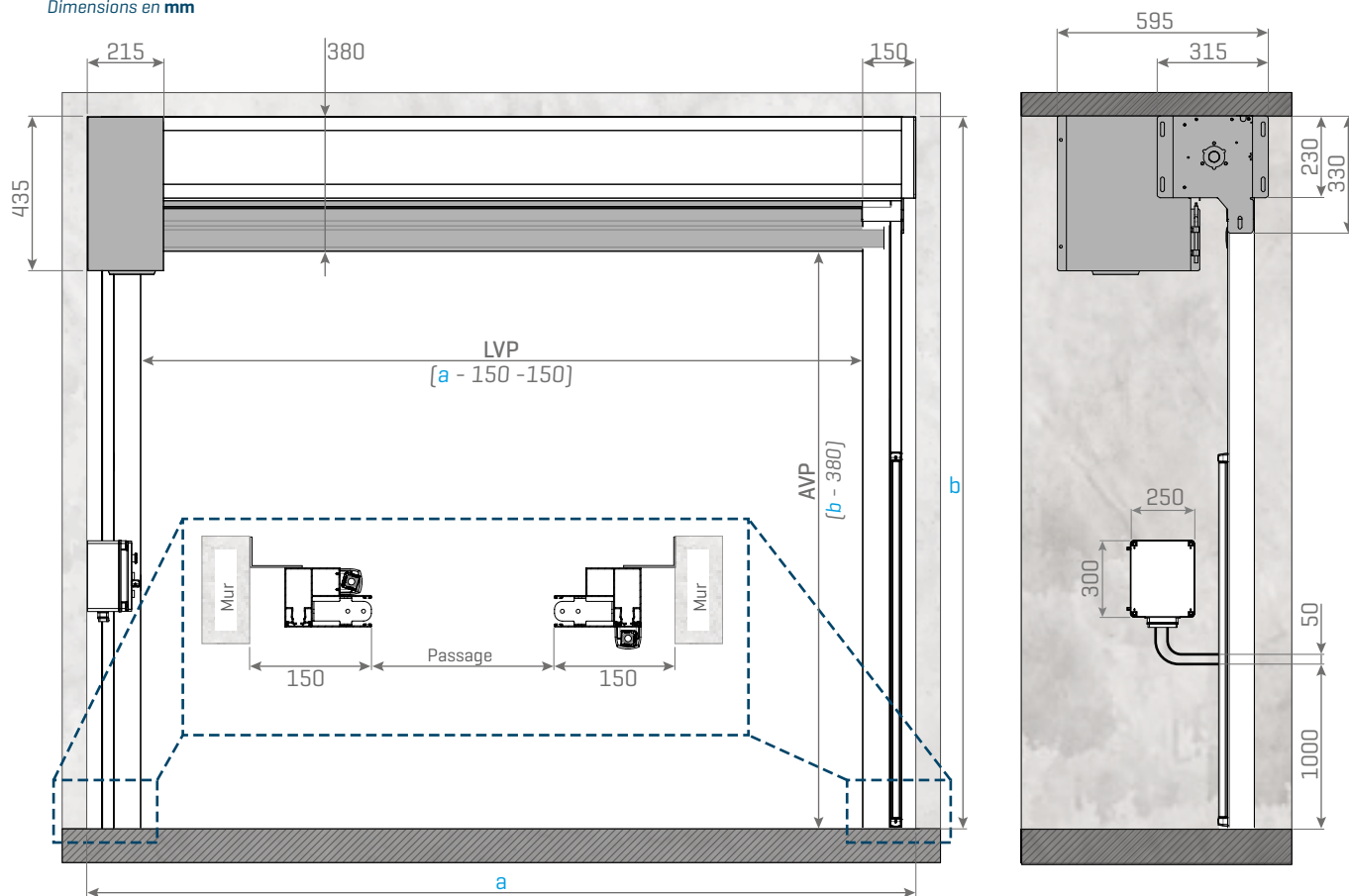

Légende: LVP - Largeur de passage; AVP - Hauteur de l'espace de passage;