

Cliente:

Ref. cliente:

Fecha:

 / /

Fecha deseada para la entrega:

 / /

01. LUGAR DE INSTALACIÓN

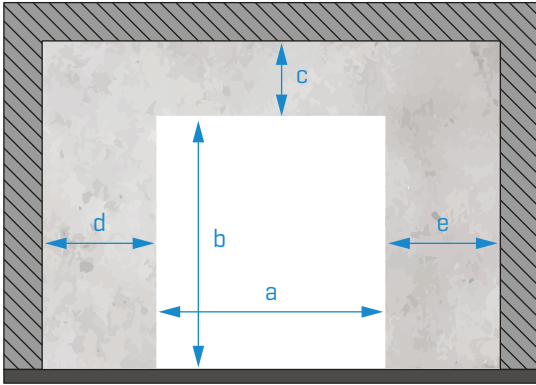

Cantidad

Dimensiones del lugar [mm]:

RELLENAR OBLIGATORIAMENTE

a

b

c

d

e

Color PVC:



Otro:

Componentes opcionales:

MPR020

Mandos

Kit túnel

Radares

Kit anti-tormenta

Espiral magnética

UPS [Precio bajo consulta]



Modelo

Todas las puertas son lacadas en **RAL9010 Texturizado**

Si desea otro color o acabado, por favor indíquelo aquí:

INOX 304

INOX 316

Sin mica transparente

Seleccione en caso **de no querer** la mica transparente

Otras opciones:

OBSERVACIONES:

[EN ESTE CAMPO DEBE DESCRIBIR TODO LO QUE CONSIDERE RELEVANTE PARA LA PRODUCCIÓN]

POSICIÓN DEL MOTOR Y DE LA CENTRAL:

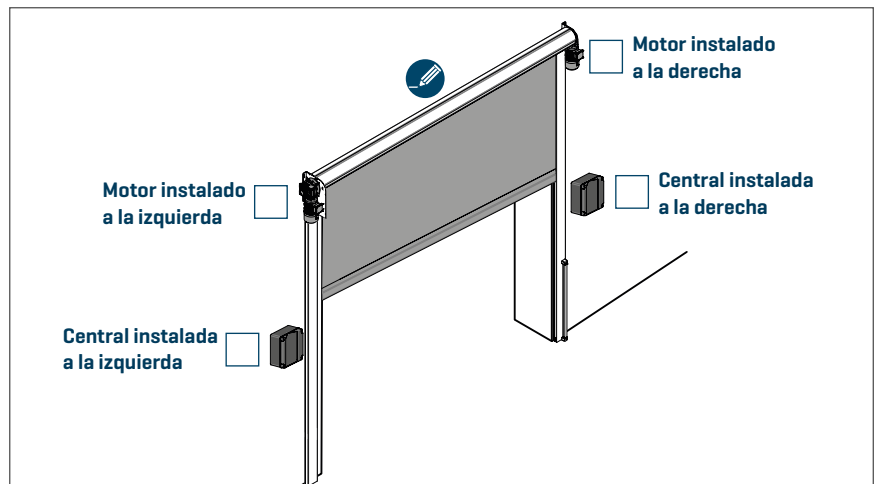

[EN ESTE CAMPO DEBE DISEÑAR TODO LO QUE CONSIDERE RELEVANTE PARA LA PRODUCCIÓN]

02. DISEÑO TÉCNICO [KIT NORMAL]

Dimensiones presentadas en mm

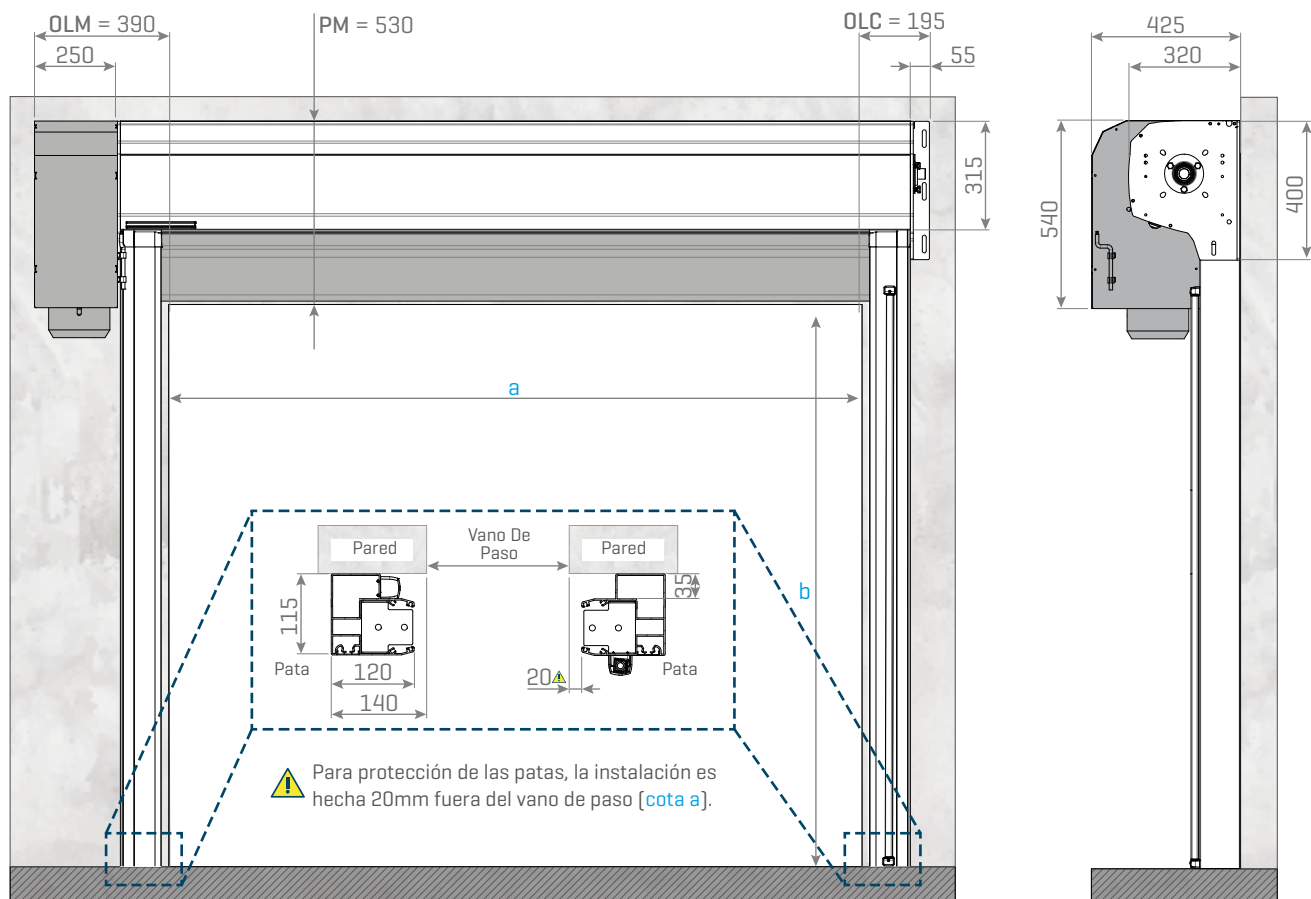

Leyenda: OLM - Umbral Lado del Motor; OLC - Umbral Lado Contrario; PM - Dintel Mínimo

03. DISEÑO TÉCNICO [KIT TÚNEL]

Dimensiones presentadas en mm

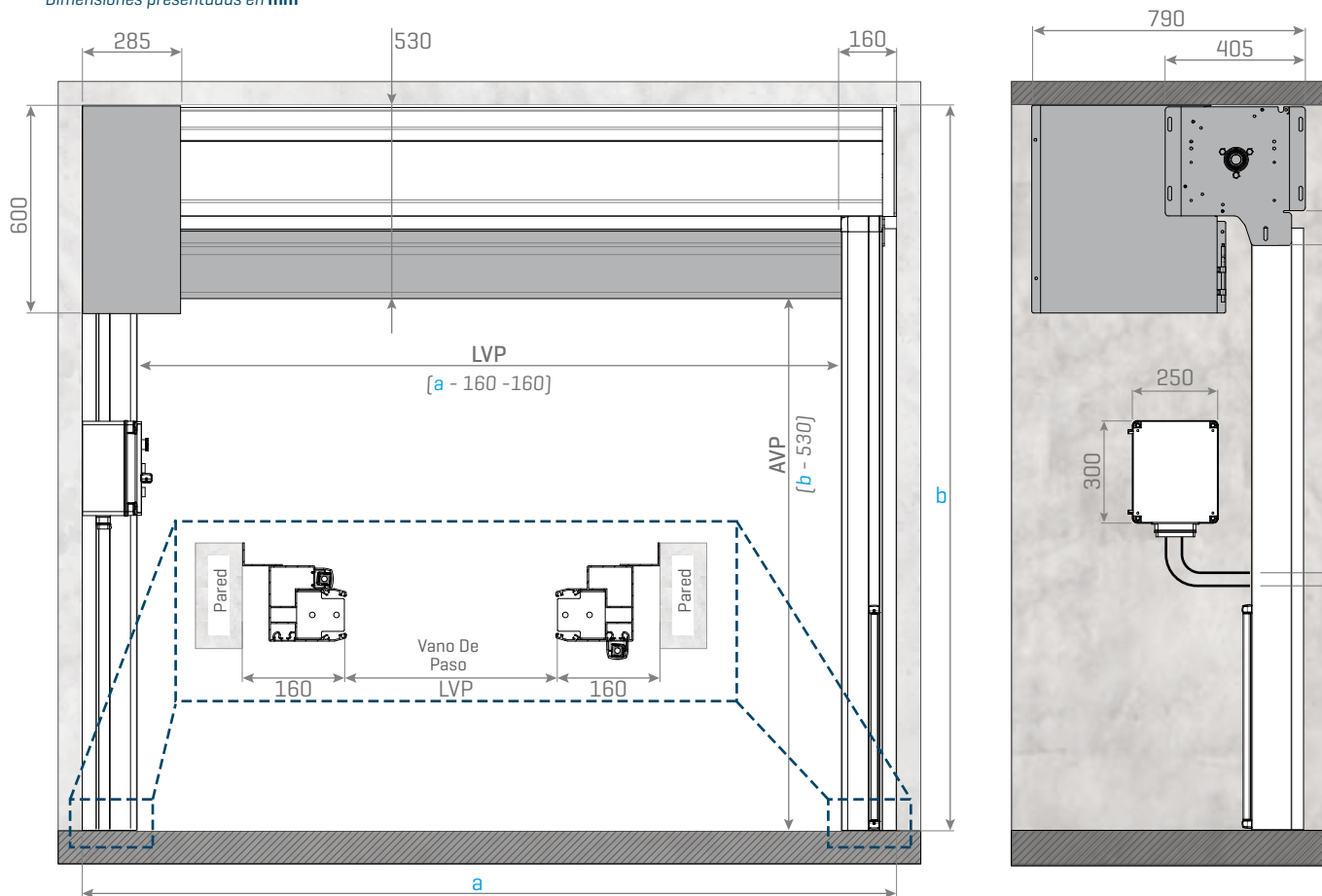

Leyenda: LVP - Ancho Del Vano De Paso; AVP - Altura del Vano de Paso;