

Client:

Réf. client :

Date:

 / /

Date désirée pour la livraison:

 / /

01. ENDROIT D'INSTALLATION

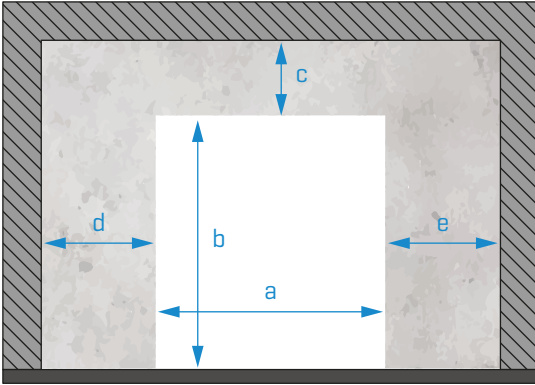

Quantité

Dimensions de l'endroit (mm):



REPLIR
OBLIGATOIREMENT

a

b

c

d

e

Couleur PVC:



5013



5002



5015



6026



3002



2004



1003



1015



9005



7037



7038



7035



9016



5010



7016

Autre:

Dispositifs supplémentaires:

MPR020

Kit tunnel

UPS (prix sur demande)

Télécommandes

Radars

Boucle magnétique



Modèle

Toutes les portes sont laquées en **RAL9010 texturé**.

Si vous souhaitez une autre couleur ou une autre finition, veuillez le mentionner ici:

INOX 304

INOX 316

Sans bande transparente

Cochez si vous **ne voulez pas** de bande transparente

Autres options:

OBSERVATIONS:

[DANS CE CHAMP, VOUS DEVEZ DÉCRIRE TOUT CE QUE VOUS PENSEZ QUI EST PERTINENT POUR LA PRODUCTION]

POSITION DU MOTEUR ET DE LA CENTRALE:

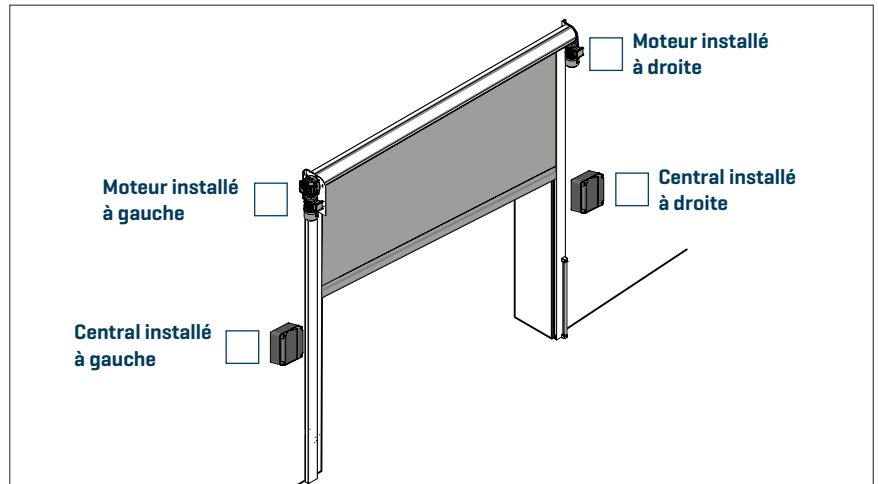

[DANS CE CHAMP, VOUS DEVEZ CONCEVOIR TOUT CE QUE VOUS PENSEZ QUI EST PERTINENT POUR LA PRODUCTION]

02. DESSIN TECHNIQUE (KIT NORMAL)

Dimensions en mm

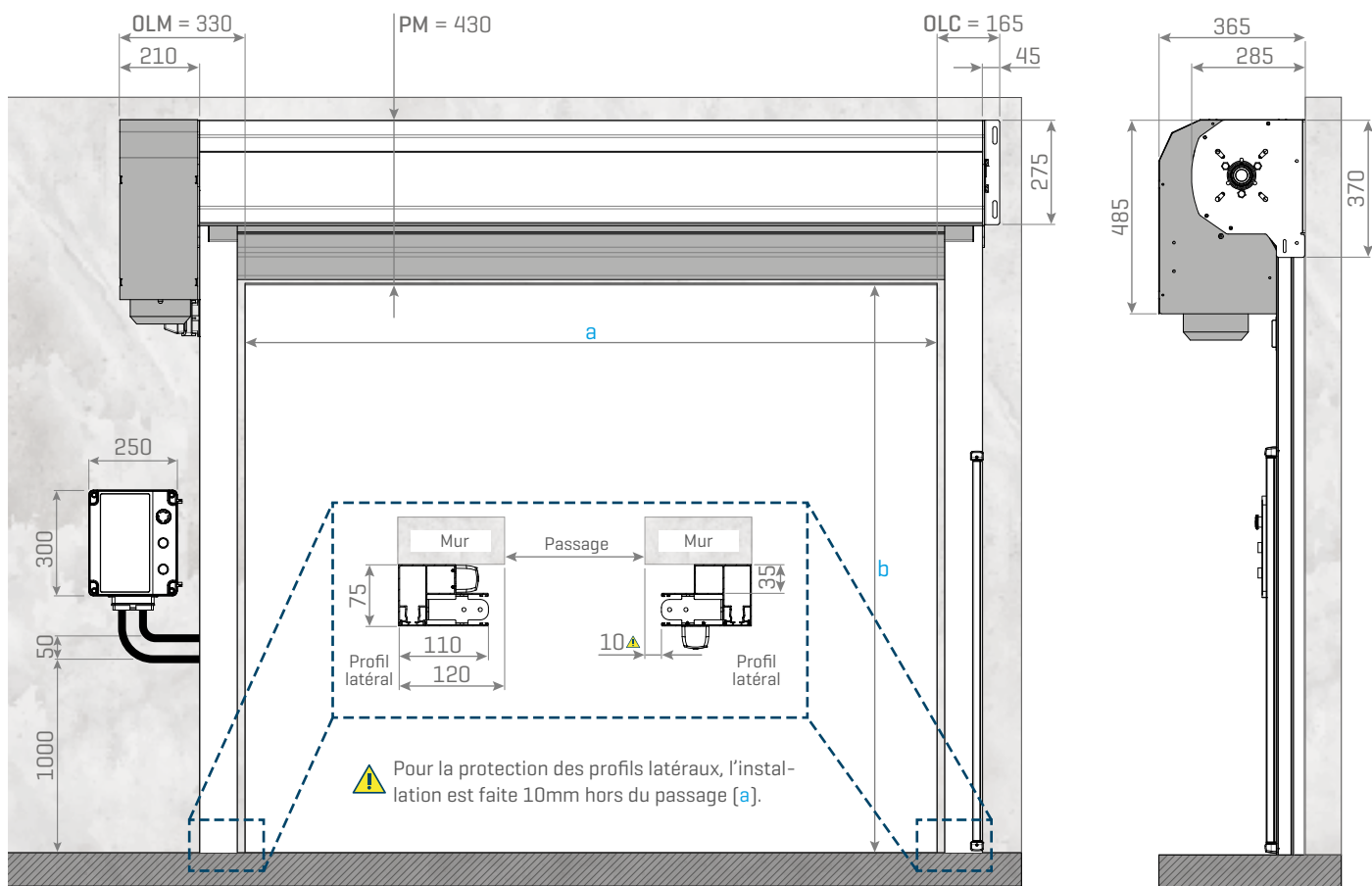

Légende: OLM - Écoinçon côté moteur; OLC - Ecoinçon côté opposé; PM - Linteau minimale

03. DESSIN TECHNIQUE (KIT TUNNEL)

Dimensions en mm

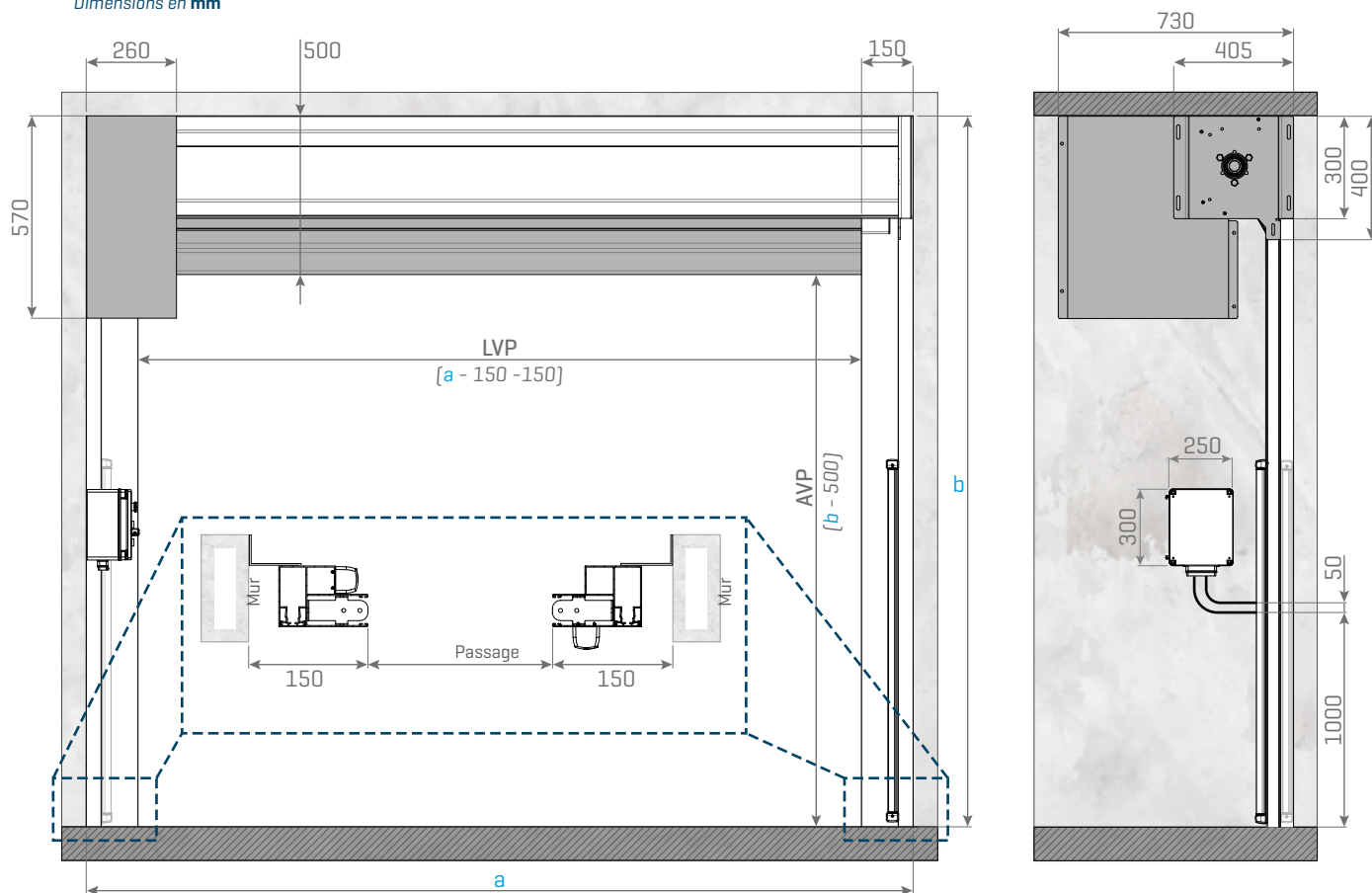

Légende: LVP - Largeur de passage; AVP - Hauteur de l'espace de passage;