

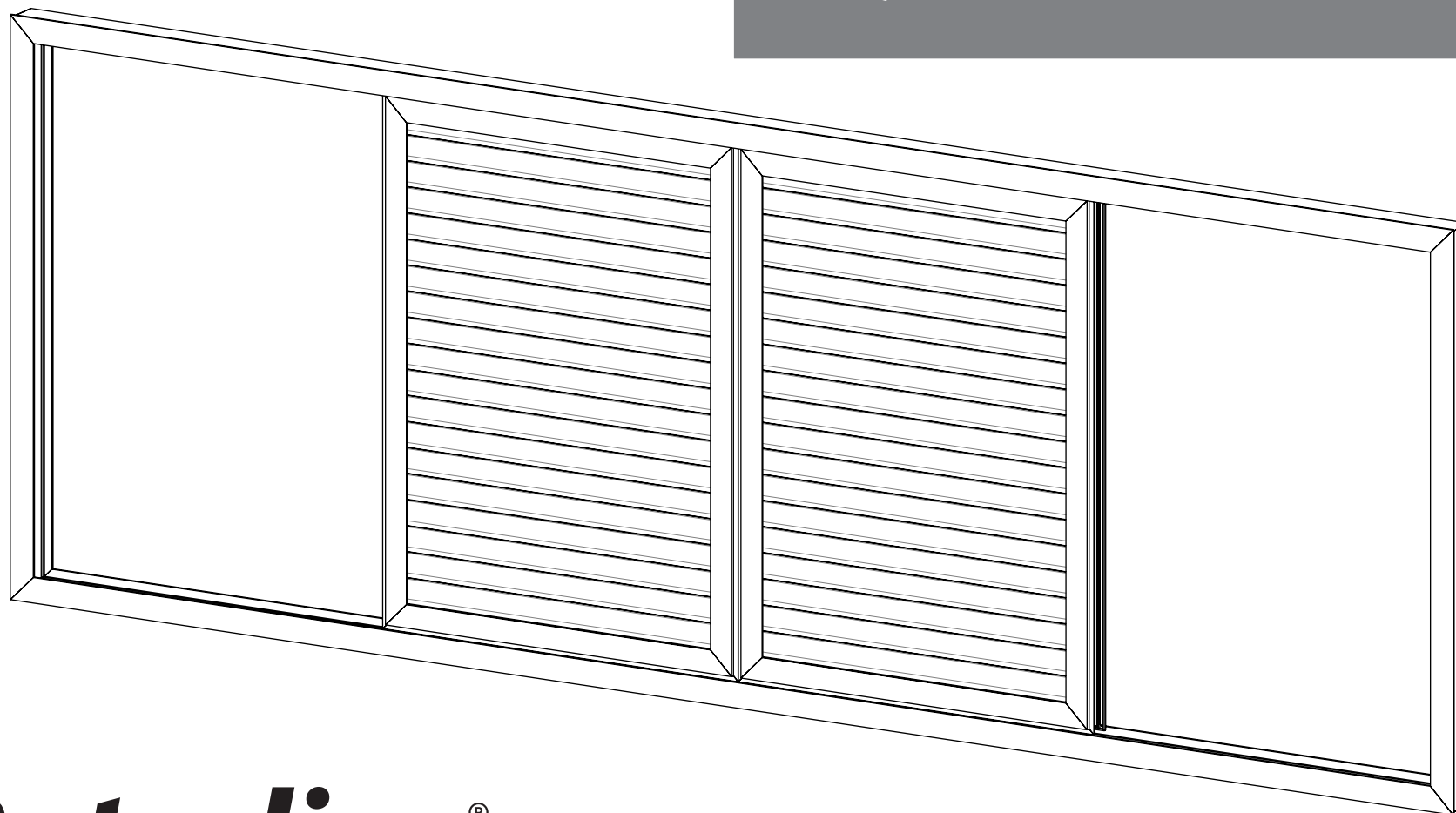

KPORTC85

USER/INSTALLER'S MANUAL



00. CONTENT

INDEX

01. SAFETY INSTRUCTIONS

STANDARDS TO FOLLOW 1B

02. CONNECTIONS SCHEME

CONNECTING COMPONENTS TO CONTROL BOARD 4

03. THE AUTOMATION

TECHNICAL CHARACTERISTICS 5A

04. INSTALLATION

AUTOMATISM INSTALLATION 5B

05. PROGRAMMING

CONTROL BOARD 6A

REMOTE CONTROL PROGRAMMING 6A







WORKING TIME PROGRAMMING 6A

PAUSE TIME PROGRAMMING 6B

POTENTIOMETERS 6B

DELETING REMOTE CONTROLS AND SETTINGS OF THE CONTROL BOARD 6B

01. SAFETY INSTRUCTIONS

	This product is certified in accordance with European Community (EC) safety standards.
	This product complies with Directive 2011/65/EU of the European Parliament and of the Council, of 8 June 2011, on the restriction of the use of certain hazardous substances in electrical and electronic equipment and with Delegated Directive (EU) 2015/863 from Commission.
	(Applicable in countries with recycling systems). This marking on the product or literature indicates that the product and electronic accessories (eg. Charger, USB cable, electronic material, controls, etc.) should not be disposed of as other household waste at the end of its useful life. To avoid possible harm to the environment or human health resulting from the uncontrolled disposal of waste, separate these items from other types of waste and recycle them responsibly to promote the sustainable reuse of material resources. Home users should contact the dealer where they purchased this product or the National Environment Agency for details on where and how they can take these items for environmentally safe recycling. Business users should contact their vendor and check the terms and conditions of the purchase agreement. This product and its electronic accessories should not be mixed with other commercial waste.
	This marking indicates that batteries should not be discarded like other household waste at the end of their useful life. Batteries must be delivered to selective collection points for recycling.
	The different types of packaging (cardboard, plastic, etc.) must be subject to selective collection for recycling. Separate packaging and recycle it responsibly.
	This marking indicates that the product and electronic accessories (eg. charger, USB cable, electronic material, controls, etc.) are susceptible to electric shock by direct or indirect contact with electricity. Be cautious when handling the product and observe all safety procedures in this manual.

01. SAFETY INSTRUCTIONS

GENERAL WARNINGS

- This manual contains very important safety and usage information. Read all instructions carefully before beginning the installation/usage procedures and keep this manual in a safe place that it can be consulted whenever necessary.
- This product is intended for use only as described in this manual. Any other enforcement or operation that is not mentioned is expressly prohibited, as it may damage the product and put people at risk causing serious injuries.
- This manual is intended firstly for specialized technicians, and does not invalidate the user's responsibility to read the "User Norms" section in order to ensure the correct functioning of the product.
- The installation and repair of this product may be done by qualified and specialized technicians, to assure every procedure are carried out in accordance with applicable rules and norms. Nonprofessional and inexperienced users are expressly prohibited of taking any action, unless explicitly requested by specialized technicians to do so.
- Installations must be frequently inspected for unbalance and the wear signals of the cables, springs, hinges, wheels, supports and other mechanical assembly parts.
- Do not use the product if it is necessary repair or adjustment is required.
- When performing maintenance, cleaning and replacement of parts, the product must be disconnected from power supply. Also including any operation that requires opening the product cover.
- The use, cleaning and maintenance of this product may be carried out by any persons aged eight years old and over and persons whose physical, sensorial or mental capacities are lower, or by persons without any knowledge of the product, provided that these are supervision and instructions given by persons with experienced in terms of usage of the product in a safe manner and who understands the risks and dangers involved.

- Children shouldn't play with the product or opening devices to avoid the motorized door or gate from being triggered involuntarily.
- If the power cable is damaged, it must be replaced by the manufacturer, after-sales service or similarly qualified personnel to avoid danger.
- The device must be disconnected from the electrical network when removing the battery.
- Ensure that blocking is avoided between the actuated part and its fixed parts due to the opening movement of the actuated part.

WARNINGS FOR TECHNICIANS

- Before beginning the installation procedures, make sure that you have all the devices and materials necessary to complete the installation of the product.
- You should note your Protection Index (IP) and operating temperature to ensure that is suitable for the installation site.
- Provide the manual of the product to the user and let them know how to handle it in an emergency.
- If the automatism is installed on a gate with a pedestrian door, a door locking mechanism must be installed while the gate is in motion.
- Do not install the product "upside down" or supported by elements do not support its weight. If necessary, add brackets at strategic points to ensure the safety of the automatism.
- Do not install the product in explosive site.
- Safety devices must protect the possible crushing, cutting, transport and danger areas of the motorized door or gate.
- Verify that the elements to be automated (gates, door, windows, blinds, etc.) are in perfect function, aligned and level. Also verify if the necessary mechanical stops are in the appropriate places.
- The control board must be installed on a safe place of any fluid (rain, moisture, etc.), dust and pests.
- You must route the various electrical cables through protective tubes, to protect them against mechanical exertions, essentially on

01. SAFETY INSTRUCTIONS

the power supply cable. Please note that all the cables must enter the control board from the bottom.

- If the automatism is to be installed at a height of more than 2,5m from the ground or other level of access, the minimum safety and health requirements for the use of work equipment workers at the work of Directive 2009/104/CE of European Parliament and of the Council of 16 September 2009.
- Attach the permanent label for the manual release as close as possible to the release mechanism.
- Disconnect means, such as a switch or circuit breaker on the electrical panel, must be provided on the product's fixed power supply leads in accordance with the installation rules.
- If the product to be installed requires power supply of 230Vac or 110Vac, ensure that connection is to an electrical panel with ground connection.
- The product is only powered by low voltage safety with control board (only at 24V motors).
- Parts/products weighing more than 20 kg must be handled with special care due to the risk of injury. It is recommended to use suitable auxiliary systems for moving or lifting heavy objects.
- Pay special attention to the danger of falling objects or uncontrolled movement of doors/gates during the installation or operation of this product.

WARNINGS FOR USERS

- Keep this manual in a safe place to be consulted whenever necessary.
- If the product has contact with fluids without being prepared, it must immediately disconnect from the power supply to avoid short circuits, and consult a specialized technician.
- Ensure that technician has provided you the product manual and informed you how to handle the product in an emergency.
- If the system requires any repair or modification, unlock the automatism, turn off the power and do not use it until all safety

conditions have been met.

- In the event of tripping of circuits breakers or fuse failure, locate the malfunction and solve it before resetting the circuit breaker or replacing the fuse. If the malfunction is not repairable by consult this manual, contact a technician.
- Keep the operation area of the motorized gate free while the gate in in motion, and do not create strength to the gate movement.
- Do not perform any operation on mechanical elements or hinges if the product is in motion.

RESPONSABILITY

- Supplier disclaims any liability if:
 - Product failure or deformation result from improper installation use or maintenance!
 - Safety norms are not followed in the installation, use and maintenance of the product.
 - Instructions in this manual are not followed.
 - Damaged is caused by unauthorized modifications
 - In these cases, the warranty is voided.

MOTORLINE ELECTROCELOS SA.

Travessa do Sobreiro, nº29
4755-474 Rio Côvo (Santa Eugénia)
Barcelos, Portugal

SYMBOLS LEGEND:



• Important safety notices



• Useful information



• Programming information



• Potentiometer information



• Connectors information



• Buttons information

02. CONNECTIONS SCHEME

CONNECTING COMPONENTS TO CONTROL BOARD

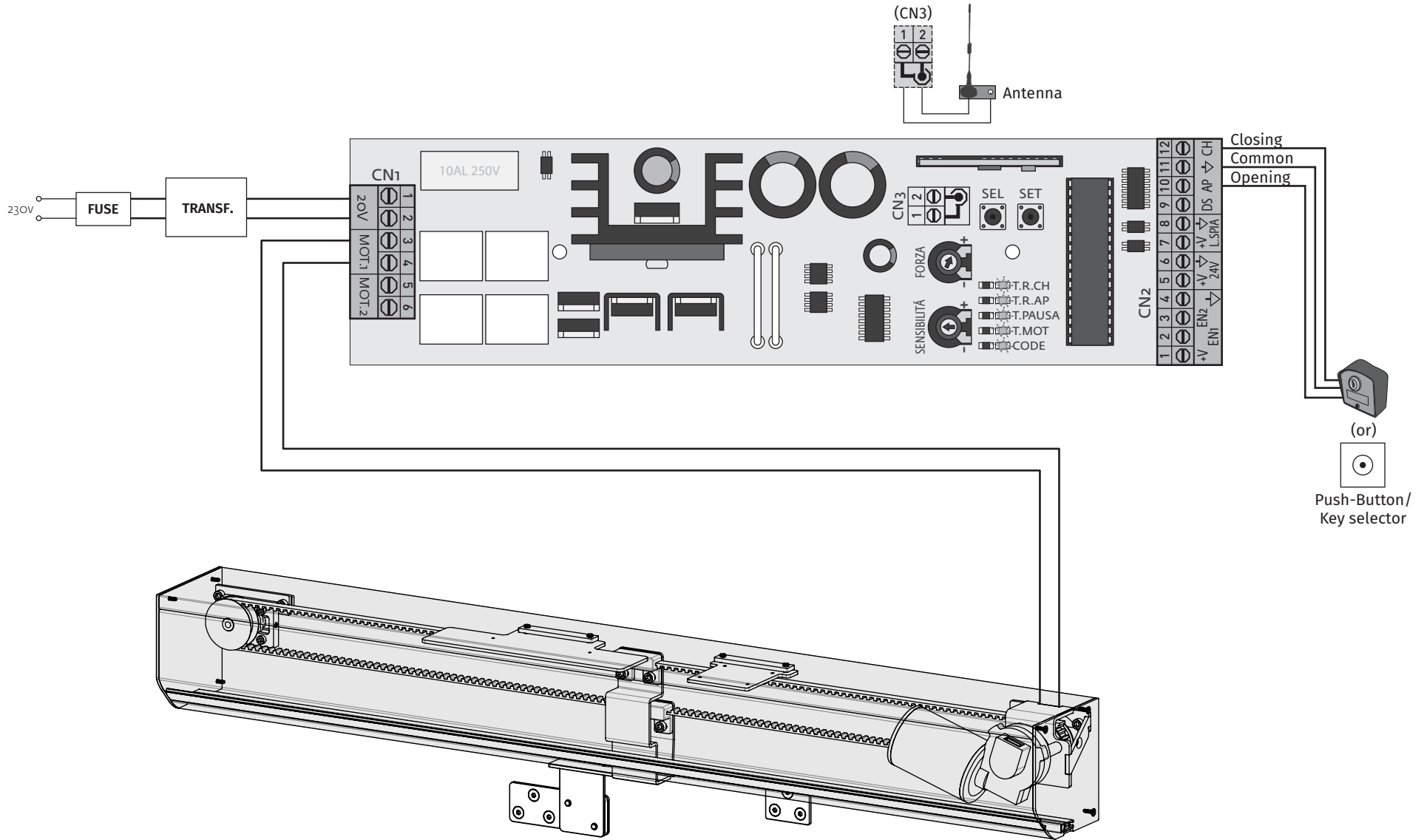

03. THE AUTOMATION

TECHNICAL CHARACTERISTICS

The **KPORTC85** is a sliding shutter kit, developed for application on leaves with a maximum of 2m² per leaf, and maximum weight of 60Kg.

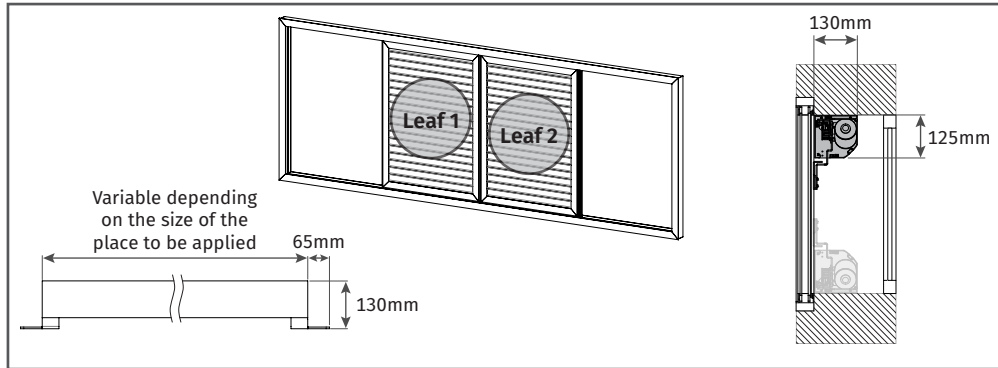

Transformer	• Primary	230Vac 50/60Hz
	• Secondary	20Vac
	• Power	30 VA
	• Dimensions	65 x 55 x 60mm
MC18	• Motor output	24 Vdc 2x50 W max.
	• Lamp Output	24 Vdc 3 W max.
	• Photocell power supply	24 Vdc 3 W max.
	• Working temperature	-10 to +55 °C
	• Radio receiver	433,92 Mhz
	• Remote controls	12-18 Bit or Rolling Code
	• Maximum memory capacity	5
	• Box dimensions	110 x 121 x 47 mm
Motor	• Power supply	24 V
	• Consumption per leaf	0.5 A
	• Torque	4Nm
	• Speed	40mm/s
	• Working temperature	-20 to +55° C
	• Protection class	IP13

04. INSTALLATION

AUTOMATISM INSTALLATION

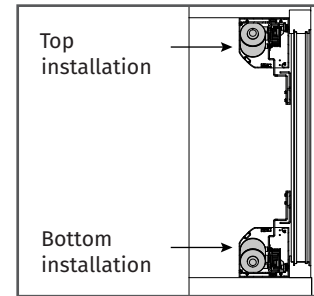

01 • Select the type of installation you want, and place the automation profile against the shutter frame.

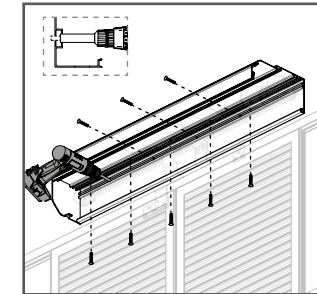

02 • Mark the holes every 30cm (approx.). You can choose to drill the holes inside the guide in the top or bottom profile.

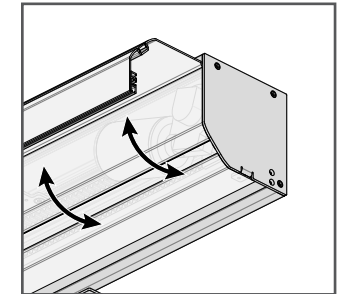

03 • Close the safe profile cover.

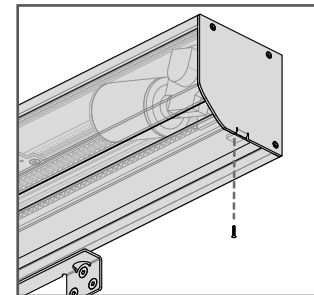

04 • Tighten the screws. If the distance between the window and the shutter is less than 200mm, the cover is only fixed with screws.

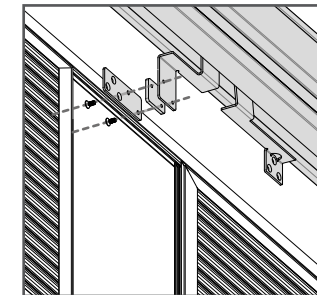

05 • Connect the support plates to the automation by tightening the screw from the inside out.

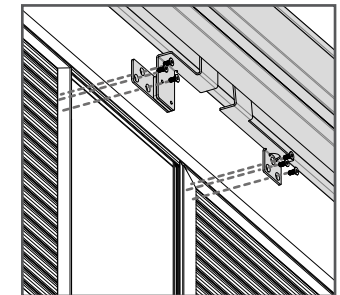

06 • Attach the support plates to the shutter.



The kit may consist of 1 or 2 leaves. When it is a 1-leaf kit, the course is 190mm less than the length of the safe profile.
Ex: 1000mm safe profile has a course of 810mm.

05. PROGRAMMING

CONTROL BOARD

LED	LED OFF	LED ON
• CODE	No code	Code inserted
• T.MOT	Motor time 30 seconds	Programmed time
• T. PAUSA	Without automatic closing	With automatic closing
• T. R.AP	Not used (LED OFF)	
• T. R. CH	Not used (LED OFF)	



- The settings must all be made with the control board connected to a 20V transformer (IN: 230V OUT: 20V) supplied in the kit.
- Whenever you perform a setting - T.MOT/T. PAUSA, etc., you must wait 10 seconds or press the SEL button as many times as necessary until all LEDs remain steady (on or off). While some LED is blinking, the control board is in programming mode.

REMOTE CONTROL PROGRAMMING



- 01 • Press the **SEL** button once, and the **CODE LED** will flash slowly.
- 02 • Press the **SEL** button again and the **CODE LED** will flash rapidly.
- 03 • Press the **↑** button of the remote control to configure it.
- 04 • The **CODE LED** will light without blinking, which means the configuration's success. The remote control is programmed with a opening button, a closing button and a Stop button.

WORKING TIME PROGRAMMING



- T.MOT LED on (soft stop enabled) / T.MOT LED off (soft stop disabled)**
- 01 • Press the **SET** button for 5 seconds until the **T.R.AP** and **T.R.CH** LEDs flash alternately and the **T.MOTOR** LED stays on. This means that you entered an extended menu of the control board.
 - 02 • Press the **SEL** button until the **T.MOTOR** LED blinks and press the **SET** button.
 - 03 • By pressing the **SET** button, the **T.MOTOR** LED will turn ON/OFF. Wait 20 seconds or turn off the power to exit the extended menu 1.

Working time without soft stop (start with closed sliding shutter(s)):

NOTE • Go to the extended menu and turn off the T.MOT LED. (See T.MOT LED warning)

- 01 • Put the sliding shutter(s) in closed position (s).
- 02 • Press the **SEL** button as many times as necessary until the T. MOT LED begins to flash.
- 03 • Press the **SET** button once, and the leaf(s) will start to open.
- 04 • When the leaf(s) reaches the open position, press **SET** once to save that position.
- 05 • Press **SET**, wait 2 seconds, and press **SET** once again.
- 06 • The leaf(s) will start to close immediately.
- 07 • When the leaf(s) reaches the closed position, press **SET** once to save this position.

Working time with soft stop (start with closed sliding shutter(s)):

NOTE • Go to the extended menu and turn on the T.MOT LED. (See T.MOT LED warning)

- 01 • Put the sliding shutter(s) in closed position (s).
- 02 • Press the **SEL** button as many times as necessary until the T. MOT LED begins to flash.
- 03 • Press the **SET** button once, and the leaf(s) will start to open. Press the **SET** button again when you

05. PROGRAMMING

WORKING TIME PROGRAMMING

want the leaf(s) to start slowing down.

04 • When the leaf(s) reaches the open position, press **SET** once to save that position.

05 • Press **SET**, wait 2 seconds, and press **SET** once again.

06 • Press **SET** again, wait 2 seconds, and press **SET** once more.

07 • The leaf(s) will start to close immediately. Press the **SET** button again when you want the leaf(s) to start slowing down.

08 • When the leaf(s) is fully closed, press **SET** once to save this position.

NOTE • To put the sliding shutters in the closed position, you have two options:

Option 1 • Disconnect the motor cables and reconnect the motors directly to a 12/24V battery until the sliding shutters are in the closed position. Reconnect the wires to the motors as they were before.

Option 2 • Perform a false working time programming to cause the motors to return to the closed position. At the end of this false programming, you can restart and make the correct programming.

PAUSE TIME PROGRAMMING (OPTIONAL)

The pause time is the time that the sliding shutter stays paused after the opening maneuver being performed and before the closing maneuver.

01 • Press the **SEL** button as many times as necessary until the **T. PAUSA** LED starts to blink.

02 • Press the **SET** button once, wait for the desired time for the pause and press the **SET** button once more, ending the pause time programming.

The time you have waited between the two times you have pressed the **SET** button will be the time the control board will wait after the end of the opening maneuver and before the sliding shutter's closing maneuver.

POTENTIOMETERS

Tune potentiometers force and sensitivity:

The force potentiometer controls the motor's force and speed when it is opening or closing.

The sensitivity potentiometer controls the sensitivity of the control board during the detection of obstacles. The more sensitive the control board is, the faster it will detect any obstacles during the course and reverse the direction of the motor.

01 • To adjust the potentiometers, simply rotate them with a small key. Turning to the right side will increase it, and turning to the left, will decrease it.



NOTE: Whenever a change to the force potentiometer is made, it is mandatory to reset the working time (see page 02.A).

DELETING REMOTE CONTROLS AND SETTINGS TO THE CONTROL BOARD

Delete remote controls:

01 • Press the **SEL** button once, and the **CODE LED** will flash slowly.

02 • Press the **SEL** button again for 5 seconds until the **CODE LED** is off. All remote controls are erased from the control board memory.

Restore all control board values to the factory values (reset):

01 • Press the **SEL** and **SET** buttons for about 5 seconds until all the LEDs light up and then go off.