



KVM205 | KVM210 | KVM215

USER/INSTALLER MANUAL









00. CONTENT

INDEX

01. SAFETY INSTRUCTIONS	1B
02. THE AUTOMATION	
TECHNICAL CHARACTERISTICS	4A
PACKAGE	4B
MOTOR DIAGRAM	5A
DIMENSIONS OF THE MOTOR AND MANEUVER BOARD	5B
03. INSTALLATION	
AUTOMATION INSTALLATION	6
INSTALLATION GUIDE	7A
04. PROGRAMMING	
MC200 CONTROL BOARD	7B
SET THE SETTINGS OF SWITCH FUNCTIONS	8A
CONNECTIONS	8A
BUTTONS	8A
DISPLAY	8B
LEDS	8B
COURSE PROGRAMMING(Working Time)	8B
AUTOMATIC CLOSING	9A
PARAMETER CONFIGURATION (P1-01 to P1-16)	9A
PARAMETER CONFIGURATION (P2-01 to P2-13)	9B
PARAMETER CONFIGURATION (P3-01 to P3-06)	10A
05. TROUBLESHOOTING	
ERRORS MAP	10B
INSTRUCTIONS FOR FINAL CONSUMERS / TECHNICIANS	11
06. CONNECTION SCHEME	
CONNECTION SCHEME	12

01. SAFETY INSTRUCTIONS

	This product is certified in accordance with European Community (EC) safety standards.
	This product complies with Directive 2011/65/EU of the European Parliament and of the Council, of 8 June 2011, on the restriction of the use of certain hazardous substances in electrical and electronic equipment and with Delegated Directive (EU) 2015/863 from Commission.
	(Applicable in countries with recycling systems). This marking on the product or literature indicates that the product and electronic accessories (eg. Charger, USB cable, electronic material, controls, etc.) should not be disposed of as other household waste at the end of its useful life. To avoid possible harm to the environment or human health resulting from the uncontrolled disposal of waste, separate these items from other types of waste and recycle them responsibly to promote the sustainable reuse of material resources. Home users should contact the dealer where they purchased this product or the National Environment Agency for details on where and how they can take these items for environmentally safe recycling. Business users should contact their vendor and check the terms and conditions of the purchase agreement. This product and its electronic accessories should not be mixed with other commercial waste.
	This marking indicates that batteries should not be discarded like other household waste at the end of their useful life. Batteries must be delivered to selective collection points for recycling.
	The different types of packaging (cardboard, plastic, etc.) must be subject to selective collection for recycling. Separate packaging and recycle it responsibly.
	This marking indicates that the product and electronic accessories (eg. charger, USB cable, electronic material, controls, etc.) are susceptible to electric shock by direct or indirect contact with electricity. Be cautious when handling the product and observe all safety procedures in this manual.

01. SAFETY INSTRUCTIONS

GENERAL WARNINGS

- This manual contains very important safety and usage information. Read all instructions carefully before beginning the installation/usage procedures and keep this manual in a safe place that it can be consulted whenever necessary.
- This product is intended for use only as described in this manual. Any other enforcement or operation that is not mentioned is expressly prohibited, as it may damage the product and put people at risk causing serious injuries.
- This manual is intended firstly for specialized technicians, and does not invalidate the user's responsibility to read the "User Norms" section in order to ensure the correct functioning of the product.
- The installation and repair of this product may be done by qualified and specialized technicians, to assure every procedure are carried out in accordance with applicable rules and norms. Nonprofessional and inexperienced users are expressly prohibited of taking any action, unless explicitly requested by specialized technicians to do so.
- Installations must be frequently inspected for unbalance and the wear signals of the cables, springs, hinges, wheels, supports and other mechanical assembly parts.
- Do not use the product if it is necessary repair or adjustment is required.
- When performing maintenance, cleaning and replacement of parts, the product must be disconnected from power supply. Also including any operation that requires opening the product cover.
- The use, cleaning and maintenance of this product may be carried out by any persons aged eight years old and over and persons whose physical, sensorial or mental capacities are lower, or by persons without any knowledge of the product, provided that these are supervision and instructions given by persons with experienced in terms of usage of the product in a safe manner and who understands the risks and dangers involved.

- Children shouldn't play with the product or opening devices to avoid the motorized door or gate from being triggered involuntarily.
- If the power cable is damaged, it must be replaced by the manufacturer, after-sales service or similarly qualified personnel to avoid danger.
- The device must be disconnected from the electrical network when removing the battery.
- Ensure that blocking is avoided between the actuated part and its fixed parts due to the opening movement of the actuated part.

WARNINGS FOR TECHNICIANS

- Before beginning the installation procedures, make sure that you have all the devices and materials necessary to complete the installation of the product.
- You should note your Protection Index (IP) and operating temperature to ensure that is suitable for the installation site.
- Provide the manual of the product to the user and let them know how to handle it in an emergency.
- If the automatism is installed on a gate with a pedestrian door, a door locking mechanism must be installed while the gate is in motion.
- Do not install the product "upside down" or supported by elements do not support its weight. If necessary, add brackets at strategic points to ensure the safety of the automatism.
- Do not install the product in explosive site.
- Safety devices must protect the possible crushing, cutting, transport and danger areas of the motorized door or gate.
- Verify that the elements to be automated (gates, door, windows, blinds, etc.) are in perfect function, aligned and level. Also verify if the necessary mechanical stops are in the appropriate places.
- The control board must be installed on a safe place of any fluid (rain, moisture, etc.), dust and pests.
- You must route the various electrical cables through protective tubes, to protect them against mechanical exertions, essentially on

01. SAFETY INSTRUCTIONS

the power supply cable. Please note that all the cables must enter the control board from the bottom.

- If the automatism is to be installed at a height of more than 2,5m from the ground or other level of access, the minimum safety and health requirements for the use of work equipment workers at the work of Directive 2009/104/CE of European Parliament and of the Council of 16 September 2009.
- Attach the permanent label for the manual release as close as possible to the release mechanism.
- Disconnect means, such as a switch or circuit breaker on the electrical panel, must be provided on the product's fixed power supply leads in accordance with the installation rules.
- If the product to be installed requires power supply of 230Vac or 110Vac, ensure that connection is to an electrical panel with ground connection.
- The product is only powered by low voltage safety with control board (only at 24V motors).
- Parts/products weighing more than 20 kg must be handled with special care due to the risk of injury. It is recommended to use suitable auxiliary systems for moving or lifting heavy objects.
- Pay special attention to the danger of falling objects or uncontrolled movement of doors/gates during the installation or operation of this product.

WARNINGS FOR USERS

- Keep this manual in a safe place to be consulted whenever necessary.
- If the product has contact with fluids without being prepared, it must immediately disconnect from the power supply to avoid short circuits, and consult a specialized technician.
- Ensure that technician has provided you the product manual and informed you how to handle the product in an emergency.
- If the system requires any repair or modification, unlock the automatism, turn off the power and do not use it until all safety

conditions have been met.

- In the event of tripping of circuits breakers or fuse failure, locate the malfunction and solve it before resetting the circuit breaker or replacing the fuse. If the malfunction is not repairable by consult this manual, contact a technician.
- Keep the operation area of the motorized gate free while the gate in in motion, and do not create strength to the gate movement.
- Do not perform any operation on mechanical elements or hinges if the product is in motion.

RESPONSABILITY

- Supplier disclaims any liability if:
 - Product failure or deformation result from improper installation use or maintenance!
 - Safety norms are not followed in the installation, use and maintenance of the product.
 - Instructions in this manual are not followed.
 - Damaged is caused by unauthorized modifications
 - In these cases, the warranty is voided.

MOTORLINE ELECTROCELOS SA.

Travessa do Sobreiro, nº29
4755-474 Rio Côvo (Santa Eugénia)
Barcelos, Portugal

SYMBOLS LEGEND:



• Important safety notices



• Useful information



• Programming information



• Potentiometer information



• Connectors information



• Buttons information

02. THE AUTOMATION

TECHNICAL CHARACTERISTICS

The **KVM205**, **KVM210** and **KVM215** are shaft-driven automations for automating industrial sectional doors, with the possibility of horizontal or vertical application. The easy installation, configuration and maintenance makes it ideal for all types of sectional doors.

	KVM205	KVM210	KVM215
Power supply	230Vac 50 Hz		
Power	650W	700W	800W
Starting force	70Nm	130Nm	200Nm
Reduction rate	1:43		
Rotation speed without load	22 RPM / 50Hz		
Maximum limit of limit switch	20 turns - using full encoder value		
Type of lubricant	Oil		
Noise	<55dB		
Shaft output hole diameter	Ø25,4mm		
Operating temperature	-25~+55° C		
Protection class	IP54		
Working frequency	25%	20%	
Thermal protection	120° C		
Motor rotational speed	24 RPM / 50Hz		
For sectional doors up to	20m ²	48m ²	60m ²

MANUAL CHAIN USE METHOD

When it is necessary to operate the door motor manually, the safety chain will be used.

It is advisable to operate the chains with uniform movements and continuous force. Sudden impulses of chain should be avoided, in order to avoid damage to the manual mechanism.

Pull the chain to open and close the door.

During pulling, protection switches located on the chain's manual mechanism automatically turn off power to prevent accidents. Once the chain returns, the manual chain mechanism will be automatically restored to its original position and the industrial door motor will be restored to its normal electrically driven state.

When safety chains are not in use, secure the chains to the wall.

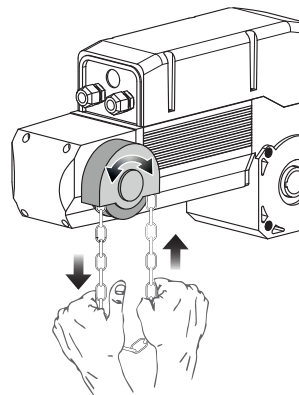

02. THE AUTOMATION

PACKAGE

- 01• 01 KVM motor
- 02• 01 Maneuver board (with control board)
- 03• 02 Motor fixing plate
- 04• 01 Current
- 05• 02 Dowel safety bushings
- 06• 04 Motor fixing screws
- 07• 01 Dowel/key
- 08• 01 Cable entry glands
- 09• 01 Hoist
- 10• 01 Gearbox for shaft

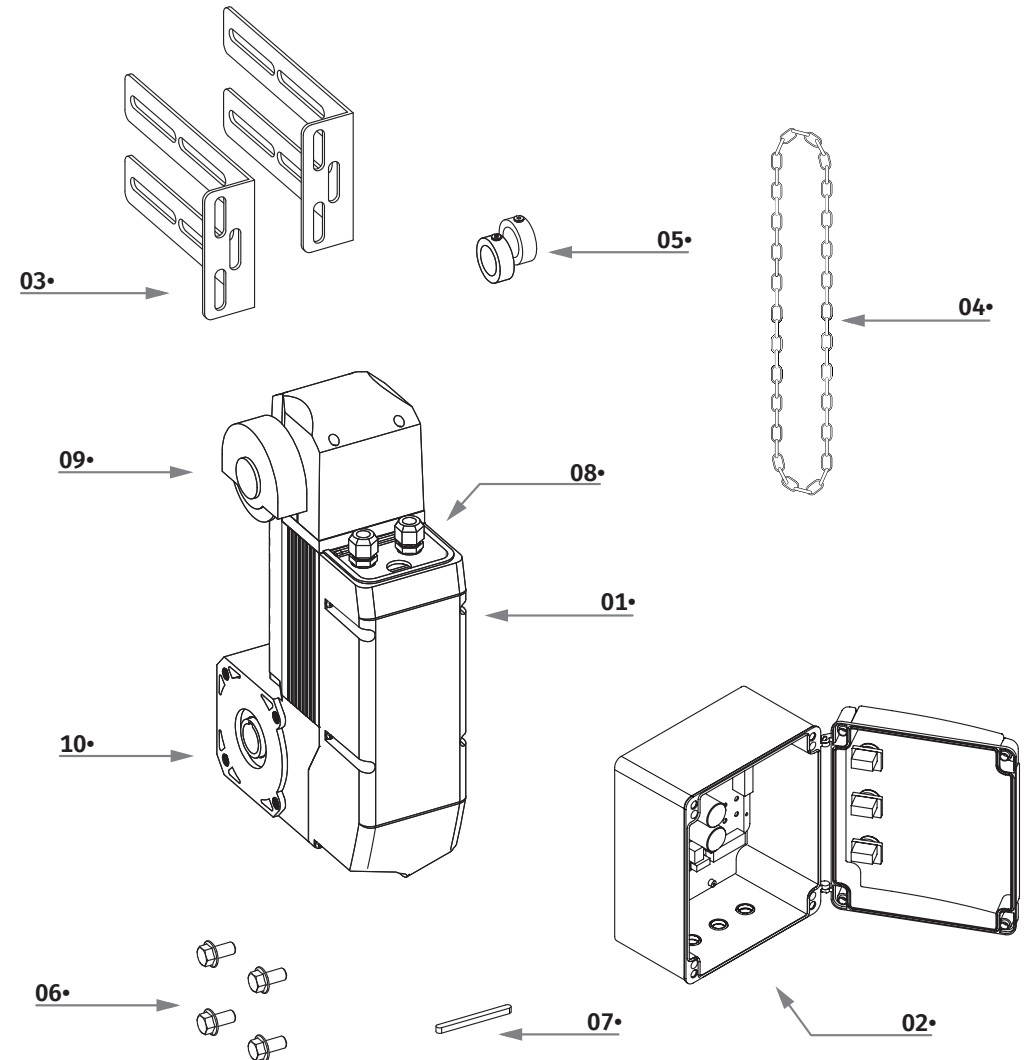

02. THE AUTOMATION

MOTOR DIAGRAM

- 01• Encoder
- 02• Motor thermal protection line
- 03• Motor lead wire
- 04• Connectors

- 05• Cable glands
- 06• Hoist protection switch
- 07• Motor power supply line
- 08• Encoder signal line

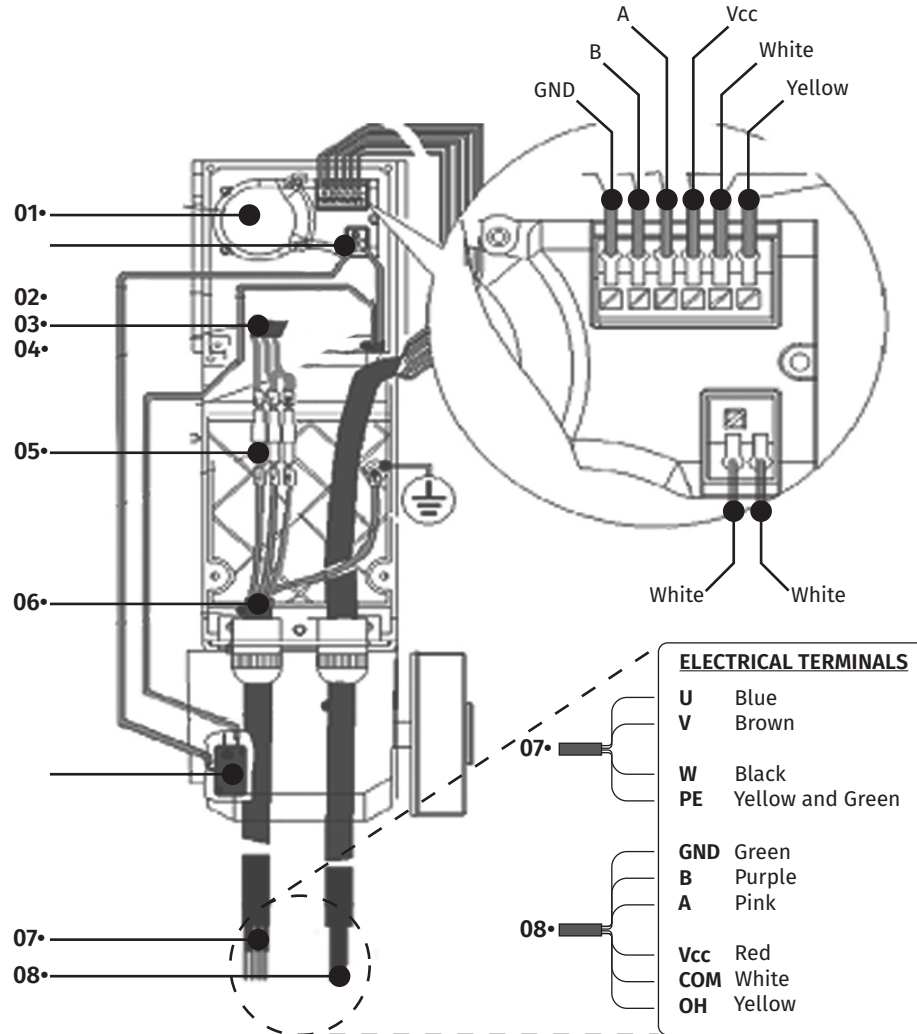

02. THE AUTOMATION

DIMENSIONS OF THE MOTOR AND MANEUVER BOARD

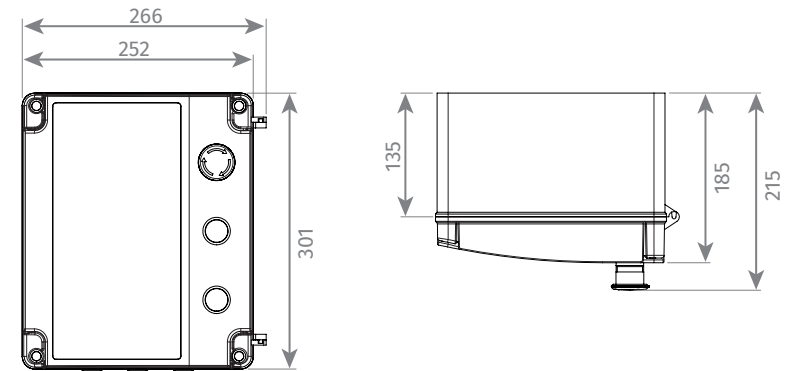
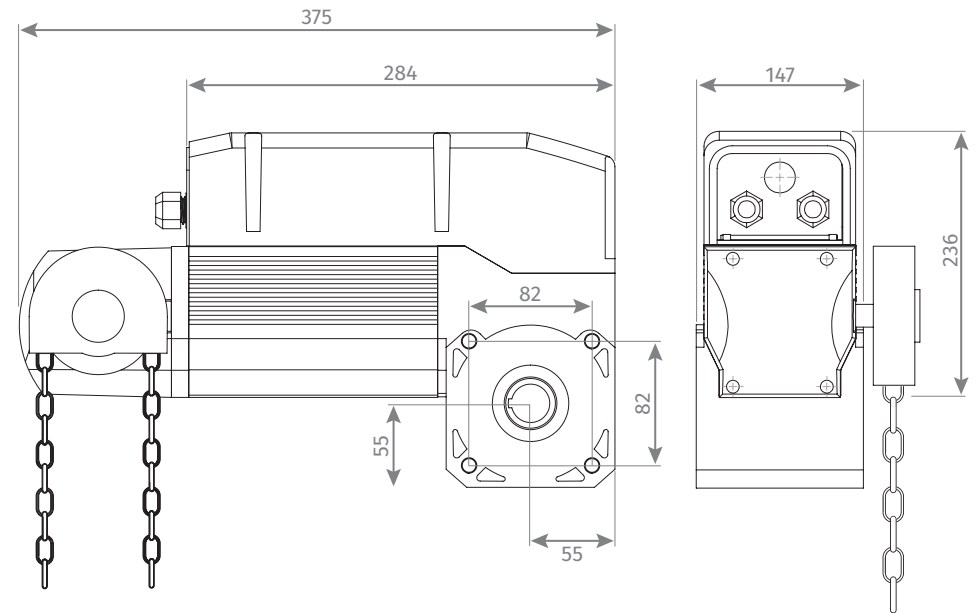

03. INSTALLATION

AUTOMATION INSTALLATION



- The gearmotor must be installed in a protected area, without risk of damage.
- The fixing surface must be solid.
- Appropriate accessories must be used to fix the motor to the fixing surface.
- Install pipes suitable for the passage of electrical cables, in order to guarantee full protection against mechanical damage.
- The door structure must be strong enough, with efficient hinges.
- There must be no friction between fixed parts and moving parts.

1 ASSEMBLE THE SHAFT

Leave an excess of 350mm on the spring shaft beyond the bracket. Insert a dowel protection bushing.

2 FITTING THE MOTOR

Place the motor on the shaft leaving about 3 to 10 cm on both sides of the motor (detail A).

3 MARK THE HOLES

Place the plates on the motor without fully tightening (one on each side). Place the plates against the wall and mark the holes.

4 DRILL THE HOLES

Remove the motor plates and drill holes to secure the motor.

5 FIX THE MOTOR

Screw the plates to the wall and then to the motor. Insert dowel and then place the dowel protection bushing, lean against the motor and tighten it.

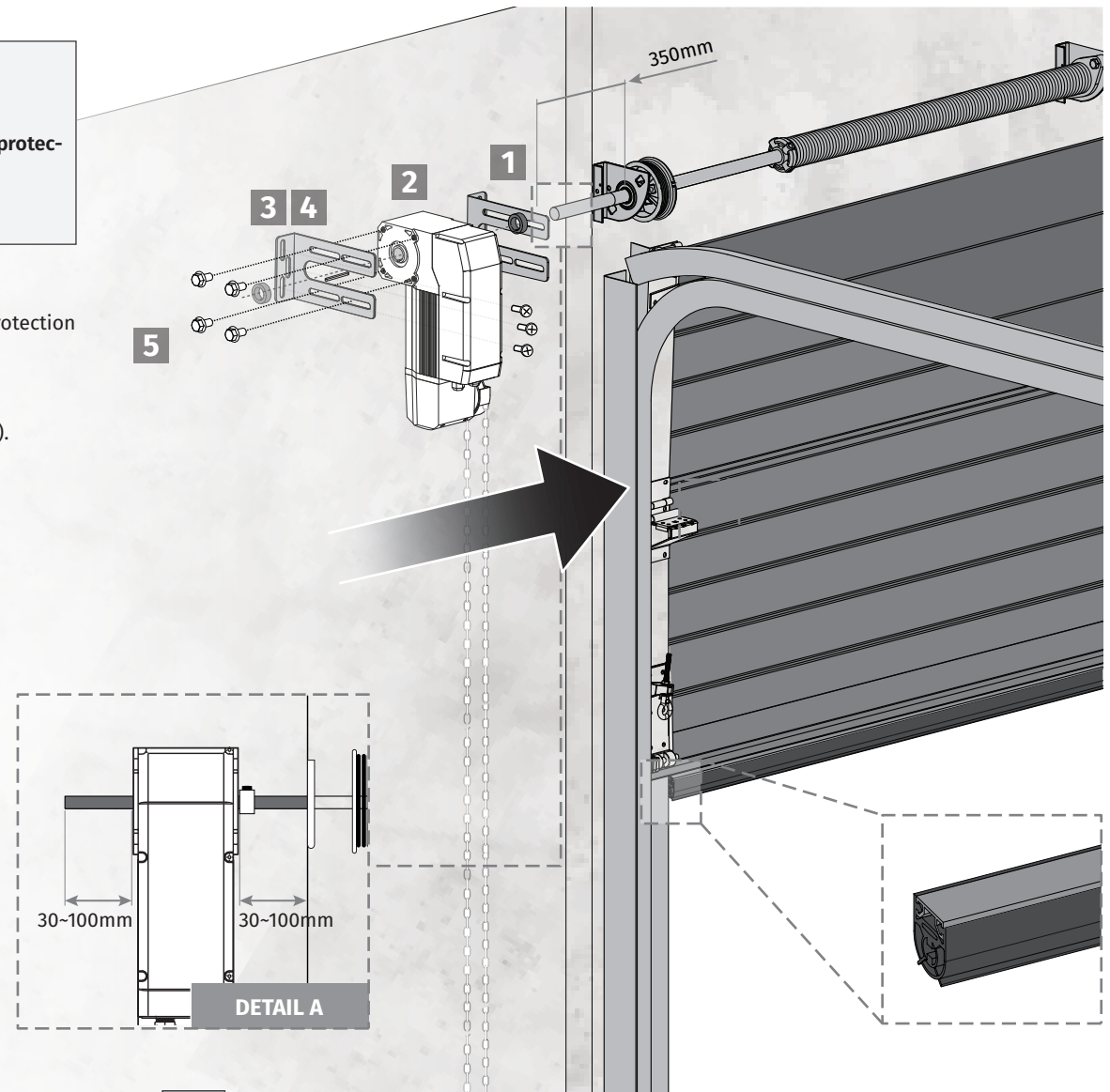
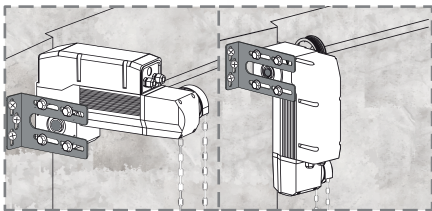

You can install the motor horizontally or vertically, the procedure is the same. See detail A.



These automations require the use of additional safety devices (example: MF2020, MR14 w/MX14, etc.), in accordance with the EN12453 standard, to detect obstacles and prevent injuries and material damage.

03. INSTALLATION

INSTALLATION GUIDE

MOTOR

Maneuver board with control board

1500mm

- 1 MARK THE HOLES**
Make a mark on the wall at a distance of 1500mm from the floor. Place the base of the switchboard on the marking. Mark the places to drill.
- 2 MAKE THE HOLES**
Drill holes in the marked locations.
- 3 FIX THE CONTROL BOARD**
Apply the anchors and fix the control board to the wall.
- 4 CONNECT THE CONTROL BOARD**
Insert the wires through the bottom of the control board. Install the control board cover. Close the cover and tighten the screws until the box is completely fixed.

03. INSTALLATION

MC200 CONTROL BOARD

Display

Main Board

1 GND
2 B
3 A
4 VCC CN2

STATUS LEDs
D15 R43
D16 R111
D17 R112
D18 R113

POWER LED
D24 R115
D23 R114

ON SWITCH
1 2

5 COM
6 OH
7 OP
8 CL
9 ST
10 RAD
11 COM CN3

12 24V
13 COM
14 INF CN4

15 FUNC
16
17 CN5

Buttons

OPEN
STOP
CLOSE KEY-6
SET

CN1

FUSE
L N PE U V W



• You must not touch the board components when it is connected to the mains (LEDs are lit).

04. PROGRAMMING

SET THE SETTINGS OF SWITCH FUNCTIONS

DIPPER



• **Dipper 1** must always be set to **OFF**

Not used



ON • allows access to the programming menu;
OFF • DOES NOT allow access to the programming menu.

CONNECTIONS

CONNECTIONS OF ELECTRIC LIMIT SWITCH		
<p>CN1</p> <ul style="list-style-type: none"> L • 230V power N • 230V power PE • Ground wire U • Motor output V • Motor output W • Motor output 	- - - Blue Brown Black	
<p>CN2</p> <ul style="list-style-type: none"> 01 • GND Negative encoder 02 • B RS485B 03 • A RS485A 04 • VCC Positive Encoder 	Green Purple Pink Red	
<p>CN3</p> <ul style="list-style-type: none"> 05 • COM Common 06 • OH Thermal protection input (NC) 07 • OP Open 08 • CL Close 09 • ST Stop 10 • RAD Pedestrian door protection (NC) or Step by Step (NO) (see options in P2-12) 11 • COM Common 	White cable Yellow cable - - - - -	
<p>CN4</p> <ul style="list-style-type: none"> 12 • +24V Output for auxiliary accessories (<i>max 200mA</i>) 13 • COM Common 14 • INF Photocells 		
<p>CN5</p> <ul style="list-style-type: none"> 15 • F1 Multifunction contact (NO) (see options P1-08) 16 • Not used 17 • CO Multifunction contact (COM) (see options P1-08) 		

BUTTONS

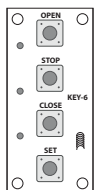



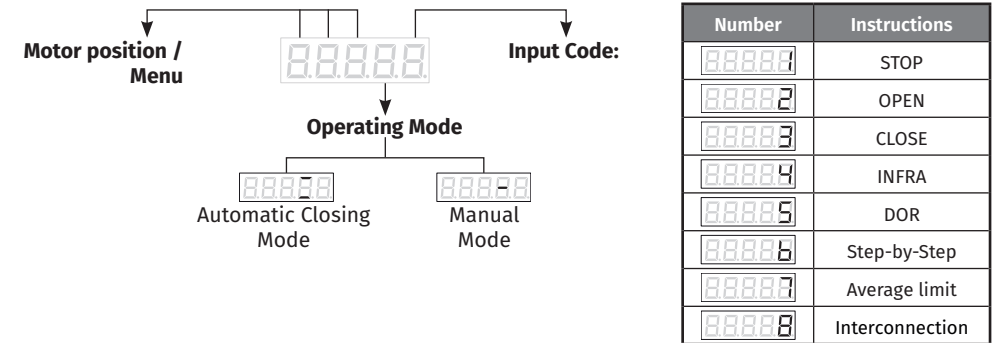

- OPEN** button: used to open the door;
- STOP** button: stops the door movement;
- CLOSE** button: used to close the door.
- SET** button: used to confirm and enter the menus;

04. PROGRAMMING

DISPLAY



LEDs

LED	DESCRIPTION	ON	OFF
D13	Power supply	Power Supply ON	Power Supply OFF
D15	OH input (hoist/motor overheating)	Everything OK	• Overheating motor • Hoist protection (ERROR 9 is displayed)
D16	OP input (OPEN button)	NC State 	NO State
D17	CL input (CLOSE button)	NC State 	NO State
D18	ST input (STOP button)	NC State 	NO State
D23	INF input (security device)	NC State 	NO State
D24	RAD input (Step-by-step button)	NC State 	NO State

COURSE PROGRAMMING (Working Time)

MEMORIZE COURSE

- 1 • Press **SET** for more than 3 seconds, the display will show **P0**, then press **SET**, the display will show **L0** (open position).
- 2 • Press and hold the **OPEN (UP)** button until the door reaches the desired opening position.
- 3 • Press **SET** to save the settings.
- 4 • The display shows **L1** (closed position).
- 5 • Press and hold the **CLOSE** button until the door descends to the desired position (Close).
- 6 • Press **SET** to save the settings.
- 7 • "0-" appears on the display, indicating that the course has been completely memorized.
- 8 • Press the STOP button 2 times

04. PROGRAMMING

AUTOMATIC CLOSING

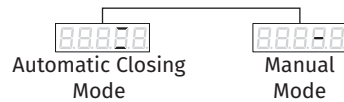

You can change the motors operating mode, between manual mode and automatic closing mode, by pressing the STOP button for 6 seconds.

In **automatic mode**, the gate, after opening, will wait the time defined in **P1-04** and then it will close. After setting the **automatic closing** value, check if it is activated in the **Operating Mode** (0000 automatic closing **activated**, 8888 automatic closing **deactivated**).

PARAMETER CONFIGURATION (P1-01 to P1-16)

- 1 • Press and hold the **SET** button for more than 3 seconds, and the display will show **P0**. Click on the **OPEN** button and select parameter **P1**.
- 2 • Then press the **SET** button to enter the **P1** parameter setting.
- 3 • Display will show **P1-01**. With the **OPEN** or **CLOSE** button, select the desired parameter between **P1-01** to **P1-16**.
- 4 • Press the **SET** button to enter the parameter and view the set value.
- 5 • Press **OPEN** or **CLOSE** to change the value to the desired value.
- 6 • Press **SET** button to save the chosen values.
- 7 • Press the **STOP** button 2 times to exit the menu.

NUMBER	INSTRUCTIONS	CONFIGURABLE VALUES	FACTORY VALUE
P1 - 01	Opening Frequency (Speed)	30 - 120Hz	60Hz
P1 - 02	Closing frequency (Speed)	30 - 120Hz	40Hz
P1 - 03	Slowdown speed	3 - 10	5
P1 - 04	Pause time	1 - 600	10
P1 - 05	Force	2 - 15	8
P1 - 06	Start ramp	5 - 20	15
P1 - 07	Deceleration time	5 - 10	10
P1 - 08	Multifunction output	0 = off; 1 = closed; 2 = open; 3 = movement; 4 = air curtain; 5=hoist alarm	0
P1 - 09	Human presence at the opening	0= off 1= activated	0
P1 - 10	Human presence at the closing	0= off 1= activated	0
P1 - 11	Opening encoder value	Only reading	
P1 - 12	Closing encoder value	Only reading	
P1 - 13	Intermediate encoder value	Only reading	
P1 - 14	Start frequency	10 - 50Hz	35Hz
P1 - 15	Inversion time	2 - 50	5
P1 - 16	Restore factory values	1 = Recovery	0

04. PROGRAMMING

PARAMETER CONFIGURATION (P2-01 a P2-13)

- 1 • Press and hold the **SET** button for more than 3 seconds, and the display will show **P0**. Click on the **OPEN** button and select the parameter **P2**.
- 2 • Then press the **SET** button to enter the **P2** parameter setting.
- 3 • Display will show **P2-01**. With the **OPEN** or **CLOSE** button, select the desired parameter between **P2-01** to **P2-13**.
- 4 • Press the **SET** button to enter the parameter and view the set value.
- 5 • Press **OPEN** or **CLOSE** to change the value to the desired value.
- 6 • Press **SET** button to save the chosen values.
- 7 • Press the **STOP** button 2 times to exit the menu.

NUMBER	INSTRUCTIONS	CONFIGURABLE VALUES	FACTORY VALUE
P2 - 01	Upper limit adjustment	0 - 50	5*
P2 - 02	Lower limit adjustment	0 - 50	10
P2 - 03	Excessive opening alarm	10 - 200	50
P2 - 04	Excessive closing alarm	10 - 200	50
P2 - 05	Distance from the gate to the ground to bypass photocells	1 - 3000**	500
P2 - 06	Current coefficient	50% - 90%	90%
P2 - 07	Braking frequency	15 - 35	20
P2 - 08	Locked rotor time	10 - 70 (at 70 this function is turned off)	30
P2 - 09	STOP type	0 = (NO) 1 = (NC)	1 = (NC)
P2 - 10	Photocell types	0 = (NO) 1 = (NC)	0 = (NO)
P2 - 11	Step-by-step function	0 = open, stop, close 1 = Step by Step	1 = (NO)
P2 - 12	Change RAD Input	0 = (NC) Stop 1 = (NO) Start - P/P	1 = (NO) Start - P/P
P2 - 13	Restore factory values	1 = recover	0

* Allows adjustment without programming.

** The maximum value varies depending on the drum diameter

04. PROGRAMMING

PARAMETER CONFIGURATION (P3-01 a P3-06)

- 1 • Press and hold the **SET** button for more than 3 seconds, and the display will show **P0**. Click on the **OPEN** button and select the parameter **P3**.
- 2 • Then press the **SET** button to enter the **P3** parameter setting.
- 3 • Display will show **P3-01**. With the **OPEN** or **CLOSE** button, select the desired parameter between **P3-01** to **P3-06**.
- 4 • Press the **SET** button to enter the parameter and view the set value.
- 5 • Press **OPEN** or **CLOSE** to change the value to the desired value.
- 6 • Press **SET** button to save the chosen values.
- 7 • Press the **STOP** button 2 times to exit the menu.

PARAMETER P3 : PASSWORD 00000			
NUMBER	INSTRUCTIONS	CONFIGURABLE VALUES	FACTORY VALUE
P3 - 01	Change password	0 - 99999	00000
P3 - 02	Working time settings (days)	0 - 99999	99999
P3 - 03	Number settings (maneuvers)	0 - 99999	99999
P3 - 04	View total elapsed time (days)	0 - 99999	Current time
P3 - 05	Check performed maneuvers	0 - 99999	Current number
P3 - 06	Restore P3 parameters to factory values	0 - 1	0



NOTE:

The values **P3-02** and **P3-03** can be set between the values **0** and **99998**. After reaching the set value, the motor will stop and **ERR06** will be shown on the display, requiring technical intervention. When the value **99999** (maximum value) is set, the motor will not enter maintenance mode and will work without limit of maneuvers and days

05. TROUBLESHOOTING

ERRORS MAP

CIRCUIT BOARD FAULT CODE - REASON AND SOLUTION			
ERROR CODE	INSTRUCTIONS	REASON	SOLUTION
ERR01	Lack of energy	Phase Loss or Neutral	1. Check Input Phase 2. Check if it has 230V
ERR02	Encoder not connected	Encoder cables	Check encoder cables and that they are correctly connected
ERR03	Anomaly in the courses	Limit not set or limit beyond set value	Program the courses again and set the opening/closing points
ERR04	Electrical short-circuit	Motor cables in short-circuit or excessive power supply	1. Check connections between control board and motor 2. Decrease the force value in P1-05 3. Increase parameter P1-06 4. Check parameter P1-07 5. Increase parameter P2-08 (max. 50)
ERR05	Overcharged motor	Motor current is greater than the set value	1. Check the force values defined in P1-05 2. Increase parameter P1-06 3. Check parameter P1-07 4. Increase parameter P2-08 (max. 50)
ERR06	End of programmed cycles	Reset execution times or number of maneuver executions	Change the cycle count
ERR07	Blocked motor	Motor contact missing (press ENTER to reset)	Check contact between motor and control board (press ENTER to restart)
ERR09	Motor thermal protection or active hoist	Waiting for the motor to cool down	Wait for the motor to cool down
ERR10	Abnormal small door	Check wires or replace switch	1. Check RAD/COM input 2. Check status in function P2-12
ERR11	Overheating of the Frequency conversion board	Inverter overheat protection	Check operation and wiring, wait for the control board to cool down, check 230V
ERR30	Communication failure on the display	The display PCB does not receive information from the control board during a specific period of time	1. Check whether the display PCB is broken 2. Check if the PCB connection to the control board is correct 3. Check if the PCB input in the electronic control board is damaged

05. TROUBLESHOOTING

INSTRUCTIONS FOR FINAL CONSUMERS / TECHNICIANS

Anomaly	Procedure	Behavior	Procedure II	Find the source of the problem
<ul style="list-style-type: none"> • Motor does not work 	<ul style="list-style-type: none"> • Check that the 230Vac power supply is connected to the automation and that it is working correctly. 	<ul style="list-style-type: none"> • Still not working 	<ul style="list-style-type: none"> • Consult a qualified MOTORLINE technician. 	<ol style="list-style-type: none"> 1 • Open the control board and check that it has a 230Vac power supply. 2 • Check the control board input fuses.
<ul style="list-style-type: none"> • Motor does not move but makes noise 	<ul style="list-style-type: none"> • Move the door manually to check the door for mechanical problems. 	<ul style="list-style-type: none"> • Did you find problems? 	<ul style="list-style-type: none"> • Consult a specialized gate technician. 	Check all axes and movement systems associated with the door automations (dowel, hinges, etc.) to find out what the problem is.
		<ul style="list-style-type: none"> • Does the door move easily? 	<ul style="list-style-type: none"> • Consult a qualified MOTORLINE technician. 	If the motor does not work, remove it and send it to MOTORLINE technical services for diagnosis.
<ul style="list-style-type: none"> • Motor opens but does not close 	<ul style="list-style-type: none"> • Manually move the door to the closed position. • Turn off the main board for 5 seconds, then turn it on again. • Give opening order with remote control. 	<ul style="list-style-type: none"> • Door opened but did not close. 	<ol style="list-style-type: none"> 1 • Check if there is any obstacle in front of the photocells; 2 • Check if any of the control devices (key selector, pushbutton, video doormen, etc.) of the door are stuck and sending a permanent signal to the control board; 3 • Consult a qualified MOTORLINE technician. 	<p>All MOTORLINE control boards have LEDs that allow you to easily conclude which devices are faulty. All safety device (DS) LEDs in normal situations remain lit. All LEDs of "START" circuits in normal situations remain off. If the device LEDs are not all on, there is a fault in the security systems (photocells, safety edges). If "START" LEDs are on, there is a remote control issuing device emitting a permanent signal.</p> <p>A) SECURITY SYSTEMS:</p> <ol style="list-style-type: none"> 1 • Shut down all security systems on the control board (consult to the manual of the control board). If the automation starts working normally, analyze which device is the problem. 2 • Remove one shunt at a time until you find the faulty device. 3 • Replace this device with a functional one, and check that the automation works correctly with all other devices. If you find any more defects, follow the same steps until you find all the problems. <p>B) START SYSTEMS:</p> <ol style="list-style-type: none"> 1 • Disconnect all connected wires from START (OPEN/CLOSE). <p>NOTE: If the procedures described in points A) and B) do not work, remove the control board and send it to MOTORLINE technical services for diagnosis.</p>
<ul style="list-style-type: none"> • Motor does not make complete course 	<ul style="list-style-type: none"> • Move the door manually to check the door for mechanical problems. 	<ul style="list-style-type: none"> • Did you find problems? 	<ul style="list-style-type: none"> • Consult a specialized gate technician. 	Check all axes and movement systems associated with the door automations (dowel, hinges, etc.) to find out what the problem is.
		<ul style="list-style-type: none"> • Does the door move easily? 	<ul style="list-style-type: none"> • Consult a qualified MOTORLINE technician. 	<p>NOTE: The tuning of the force of the control board must be enough to open and close the door without stopping it, but with a little effort from a person to stop it. In case of failure of the security systems, the door can never cause physical damage to obstacles (vehicles, people, etc).</p>

06. CONNECTION SCHEME

CONNECTION SCHEME

