

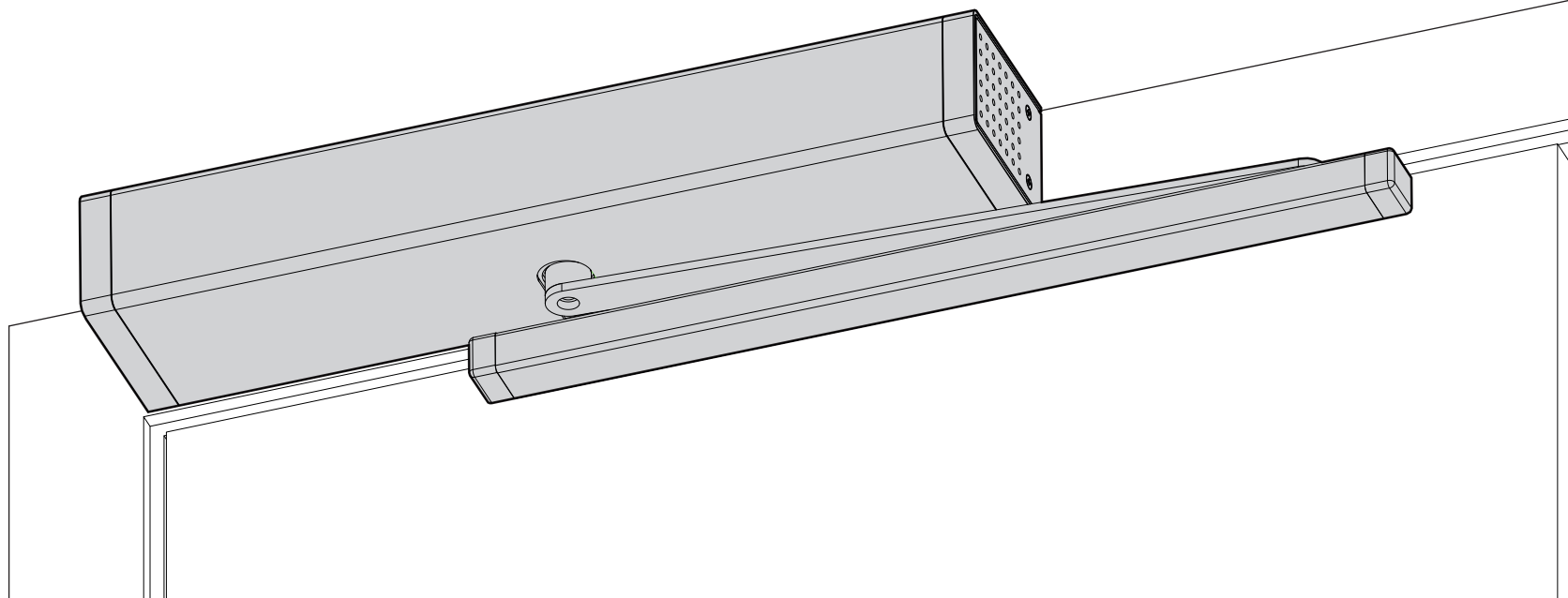

# M1805

## USER/INSTALLER MANUAL









# 00. CONTENT

## INDEX

<b>01. SAFETY INSTRUCTIONS</b>	<b>2B</b>
<b>02. CONNECTION SCHEMES</b>	
COMPONENTS CONNECTION	5
RADARS AND PROGRAM SELECTOR CONNECTION	6
CONNECTION OF 2 SINGULAR DOORS WITH INTERLOCK	7
DOOR WITH 2 LEAVES	8
<b>03. THE AUTOMATION</b>	
TECHNICAL CHARACTERISTICS	9A
<b>04. PRE-INSTALLATION</b>	
KIT	9B
WIDTH/WEIGHT RATIO	9B
INSTALLATION MEASURES   OPENING DIRECTION	10A
<b>05. INSTALLATION</b>	
INSTALLATION PROCESS	11A
<b>06. THE CONTROL BOARD</b>	
TECHNICAL CHARACTERISTICS	12A
PROGRAMMING	12B
<b>07. TROUBLESHOOTING</b>	
INSTRUCTIONS FOR FINAL CONSUMERS	13
INSTRUCTIONS FOR SPECIALIZED INSTALLERS	13

# 01. SAFETY INSTRUCTIONS

	This product is certified in accordance with European Community (EC) safety standards.
	This product complies with Directive 2011/65/EU of the European Parliament and of the Council, of 8 June 2011, on the restriction of the use of certain hazardous substances in electrical and electronic equipment and with Delegated Directive (EU) 2015/863 from Commission.
	(Applicable in countries with recycling systems). This marking on the product or literature indicates that the product and electronic accessories (eg. Charger, USB cable, electronic material, controls, etc.) should not be disposed of as other household waste at the end of its useful life. To avoid possible harm to the environment or human health resulting from the uncontrolled disposal of waste, separate these items from other types of waste and recycle them responsibly to promote the sustainable reuse of material resources. Home users should contact the dealer where they purchased this product or the National Environment Agency for details on where and how they can take these items for environmentally safe recycling. Business users should contact their vendor and check the terms and conditions of the purchase agreement. This product and its electronic accessories should not be mixed with other commercial waste.
	This marking indicates that batteries should not be discarded like other household waste at the end of their useful life. Batteries must be delivered to selective collection points for recycling.
	The different types of packaging (cardboard, plastic, etc.) must be subject to selective collection for recycling. Separate packaging and recycle it responsibly.
	This marking indicates that the product and electronic accessories (eg. charger, USB cable, electronic material, controls, etc.) are susceptible to electric shock by direct or indirect contact with electricity. Be cautious when handling the product and observe all safety procedures in this manual.

# 01. SAFETY INSTRUCTIONS

## **GENERAL WARNINGS**

- This manual contains very important safety and usage information. Read all instructions carefully before beginning the installation/usage procedures and keep this manual in a safe place that it can be consulted whenever necessary.
- This product is intended for use only as described in this manual. Any other enforcement or operation that is not mentioned is expressly prohibited, as it may damage the product and put people at risk causing serious injuries.
- This manual is intended firstly for specialized technicians, and does not invalidate the user's responsibility to read the "User Norms" section in order to ensure the correct functioning of the product.
- The installation and repair of this product may be done by qualified and specialized technicians, to assure every procedure are carried out in accordance with applicable rules and norms. Nonprofessional and inexperienced users are expressly prohibited of taking any action, unless explicitly requested by specialized technicians to do so.
- Installations must be frequently inspected for unbalance and the wear signals of the cables, springs, hinges, wheels, supports and other mechanical assembly parts.
- Do not use the product if it is necessary repair or adjustment is required.
- When performing maintenance, cleaning and replacement of parts, the product must be disconnected from power supply. Also including any operation that requires opening the product cover.
- The use, cleaning and maintenance of this product may be carried out by any persons aged eight years old and over and persons whose physical, sensorial or mental capacities are lower, or by persons without any knowledge of the product, provided that these are supervision and instructions given by persons with experienced in terms of usage of the product in a safe manner and who understands the risks and dangers involved.

- Children shouldn't play with the product or opening devices to avoid the motorized door or gate from being triggered involuntarily.
- If the power cable is damaged, it must be replaced by the manufacturer, after-sales service or similarly qualified personnel to avoid danger.
- The device must be disconnected from the electrical network when removing the battery.
- Ensure that blocking is avoided between the actuated part and its fixed parts due to the opening movement of the actuated part.

## **WARNINGS FOR TECHNICIANS**

- Before beginning the installation procedures, make sure that you have all the devices and materials necessary to complete the installation of the product.
- You should note your Protection Index (IP) and operating temperature to ensure that is suitable for the installation site.
- Provide the manual of the product to the user and let them know how to handle it in an emergency.
- If the automatism is installed on a gate with a pedestrian door, a door locking mechanism must be installed while the gate is in motion.
- Do not install the product "upside down" or supported by elements do not support its weight. If necessary, add brackets at strategic points to ensure the safety of the automatism.
- Do not install the product in explosive site.
- Safety devices must protect the possible crushing, cutting, transport and danger areas of the motorized door or gate.
- Verify that the elements to be automated (gates, door, windows, blinds, etc.) are in perfect function, aligned and level. Also verify if the necessary mechanical stops are in the appropriate places.
- The control board must be installed on a safe place of any fluid (rain, moisture, etc.), dust and pests.
- You must route the various electrical cables through protective tubes, to protect them against mechanical exertions, essentially on

# 01. SAFETY INSTRUCTIONS

the power supply cable. Please note that all the cables must enter the control board from the bottom.

- If the automatism is to be installed at a height of more than 2,5m from the ground or other level of access, the minimum safety and health requirements for the use of work equipment workers at the work of Directive 2009/104/CE of European Parliament and of the Council of 16 September 2009.
- Attach the permanent label for the manual release as close as possible to the release mechanism.
- Disconnect means, such as a switch or circuit breaker on the electrical panel, must be provided on the product's fixed power supply leads in accordance with the installation rules.
- If the product to be installed requires power supply of 230Vac or 110Vac, ensure that connection is to an electrical panel with ground connection.
- The product is only powered by low voltage safety with control board (only at 24V motors).
- Parts/products weighing more than 20 kg must be handled with special care due to the risk of injury. It is recommended to use suitable auxiliary systems for moving or lifting heavy objects.
- Pay special attention to the danger of falling objects or uncontrolled movement of doors/gates during the installation or operation of this product.

## WARNINGS FOR USERS

- Keep this manual in a safe place to be consulted whenever necessary.
- If the product has contact with fluids without being prepared, it must immediately disconnect from the power supply to avoid short circuits, and consult a specialized technician.
- Ensure that technician has provided you the product manual and informed you how to handle the product in an emergency.
- If the system requires any repair or modification, unlock the automatism, turn off the power and do not use it until all safety

conditions have been met.

- In the event of tripping of circuits breakers or fuse failure, locate the malfunction and solve it before resetting the circuit breaker or replacing the fuse. If the malfunction is not repairable by consult this manual, contact a technician.
- Keep the operation area of the motorized gate free while the gate in in motion, and do not create strength to the gate movement.
- Do not perform any operation on mechanical elements or hinges if the product is in motion.

## RESPONSABILITY

- Supplier disclaims any liability if:
  - Product failure or deformation result from improper installation use or maintenance!
  - Safety norms are not followed in the installation, use and maintenance of the product.
  - Instructions in this manual are not followed.
  - Damaged is caused by unauthorized modifications
  - In these cases, the warranty is voided.

## **MOTORLINE ELECTROCELOS SA.**

Travessa do Sobreiro, nº29  
4755-474 Rio Côvo (Santa Eugénia)  
Barcelos, Portugal

## SYMBOLS LEGEND:



• Important safety notices



• Useful information



• Programming information



• Potentiometer information



• Connectors information



• Buttons information

# 02. CONNECTION SCHEMES

## COMPONENTS CONNECTION

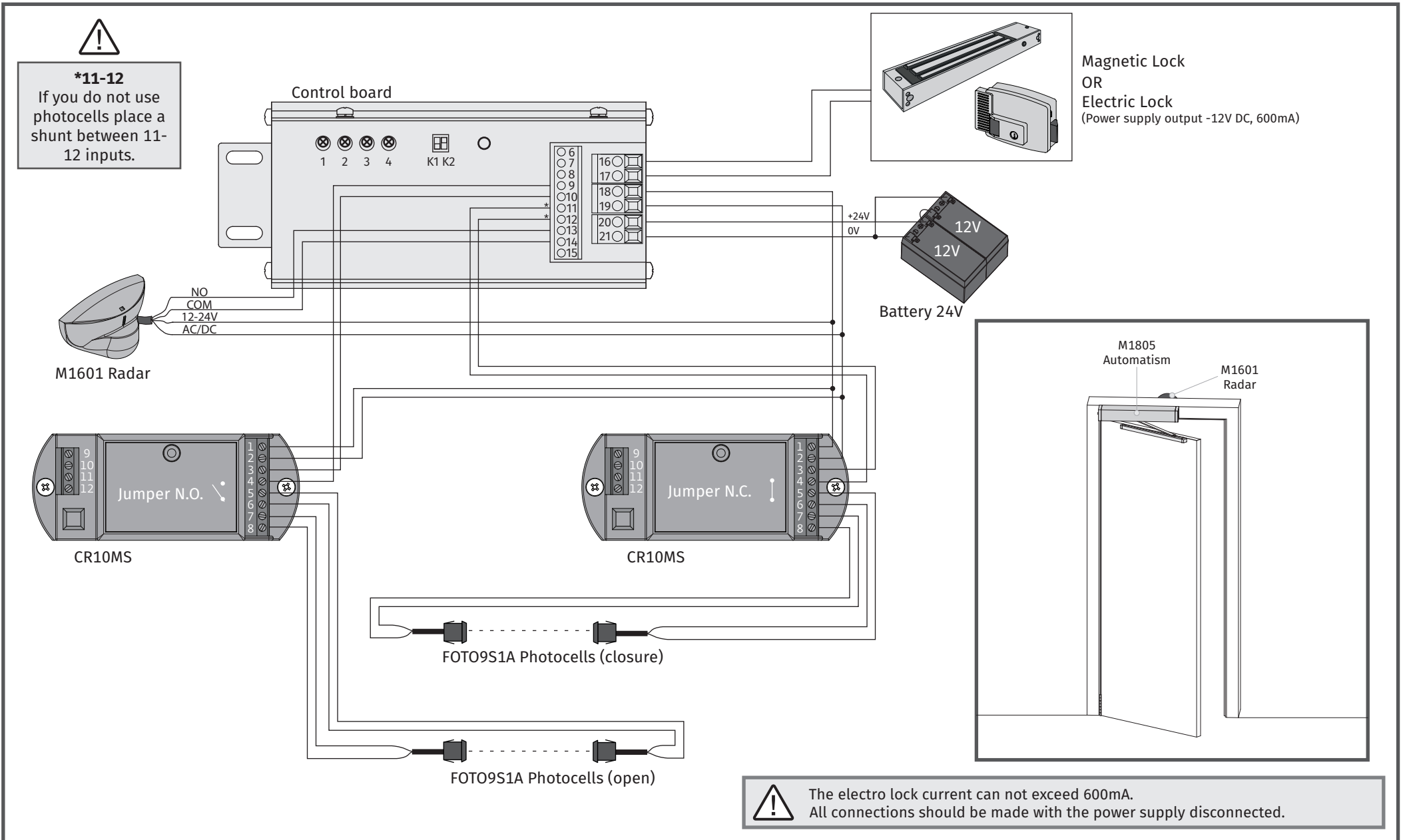

## 02. CONNECTION SCHEMES

### RADARS AND PROGRAM SELECTOR CONNECTION

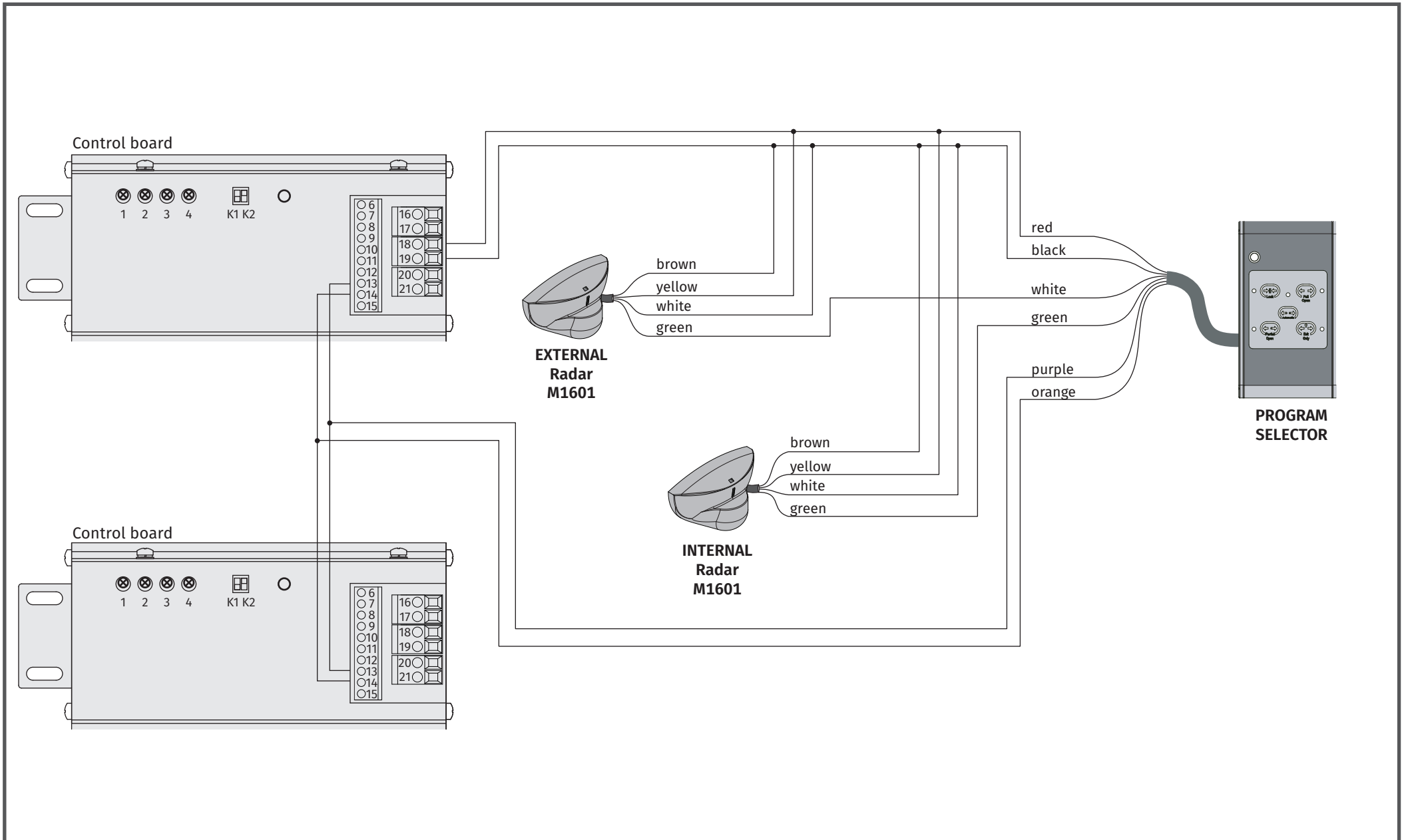

## 02. CONNECTION SCHEMES

### CONNECTION OF 2 SINGULAR DOORS WITH INTERLOCK

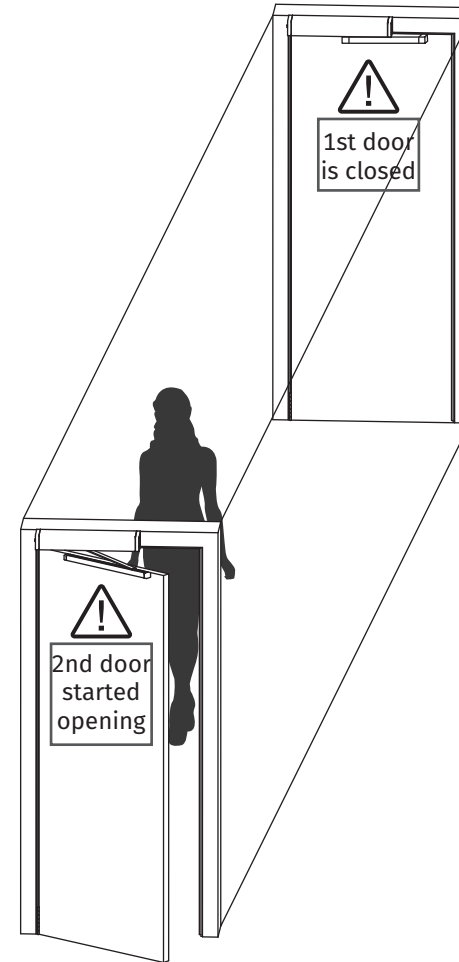
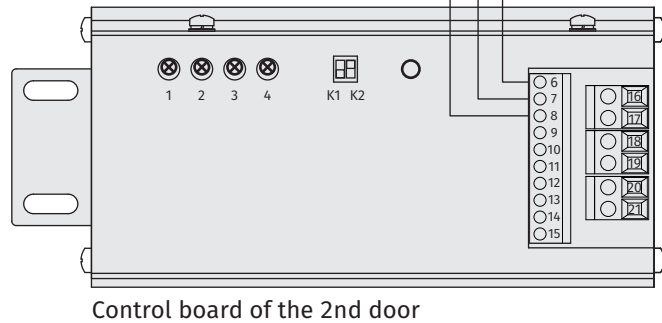
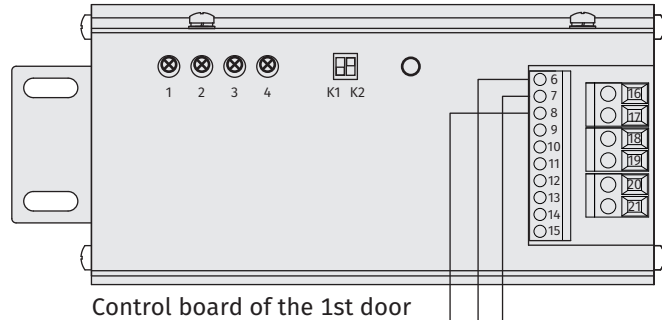

All connections should be made with the power off.



To use this function, both control panels must have K1 in the ON position.

**Operation:** When using 2 singular doors with interlocking, connected to each other, you should be aware these connections. Only when one of the doors is closed, the other can open. When using this function, if one of the doors is disconnected from the electric current, the other will not open.

## 02. CONNECTION SCHEMES

### DOOR WITH 2 LEAVES

**Operation:** When using a door with two leaves, you should note these connections. This function will allow the two sheets work in a coordinated manner.

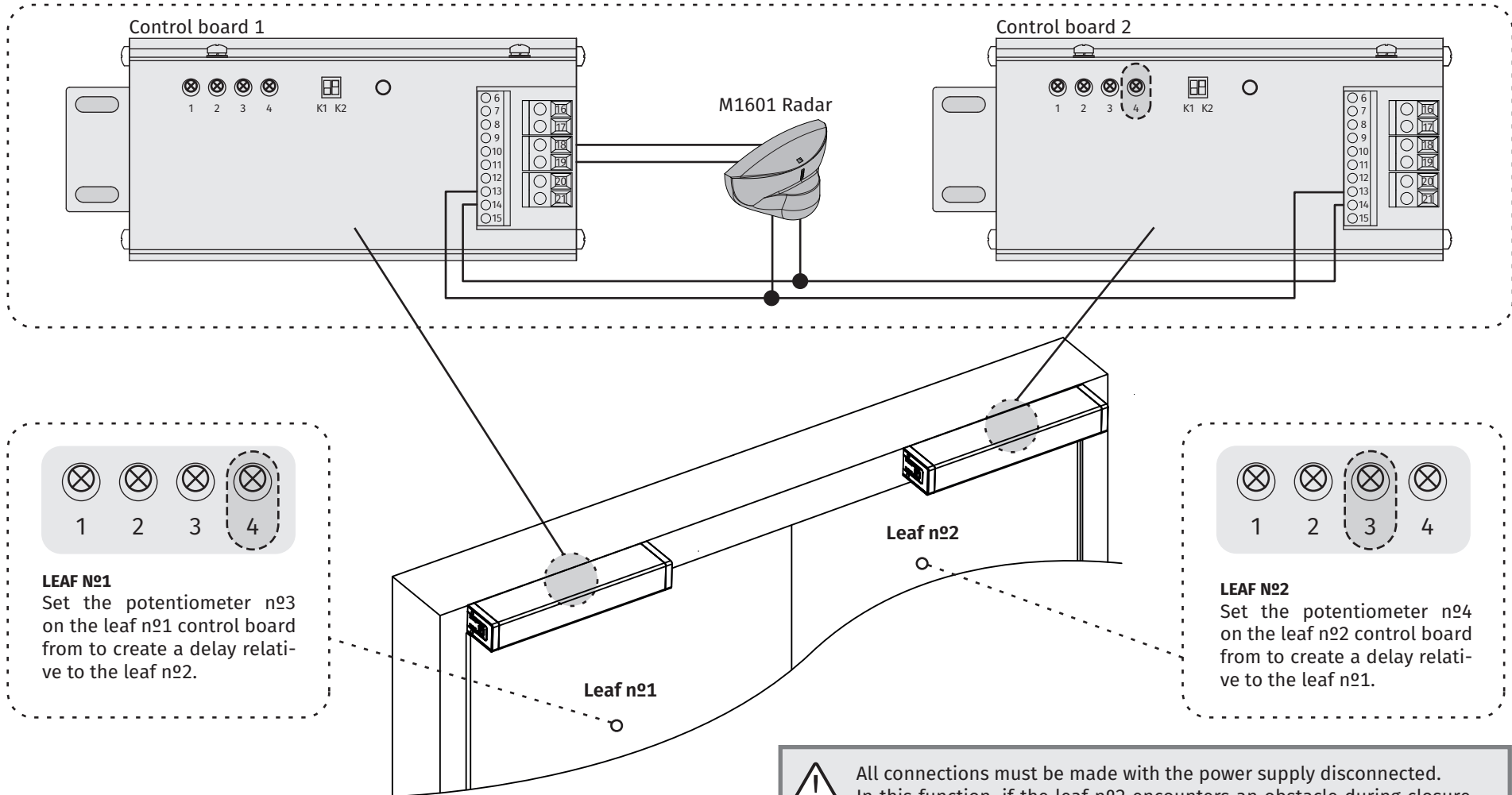

#### LEAF N°1

Set the potentiometer n°3 on the leaf n°1 control board from to create a delay relative to the leaf n°2.

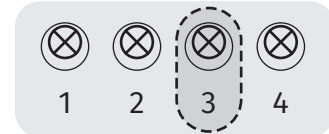

#### LEAF N°2

Set the potentiometer n°4 on the leaf n°2 control board from to create a delay relative to the leaf n°1.



All connections must be made with the power supply disconnected. In this function, if the leaf n°2 encounters an obstacle during closure, the micro will give opening order to the 2 leaves automatically, for a correct closure.



## 03. THE AUTOMATION

### TECHNICAL CHARACTERISTICS

The M1805 is an automation with anodized aluminum chassis, developed to use in pedestrian doors up to 100kg.

- The control board is microprocessor controlled and does self programming. Users only need to select the speeds and the pause time.
- The automation has obstacle detection function and self-protection for overheating, over-voltage and overcurrent.

• Power Supply	230V AC 50Hz
• Potency	100W max
• Door Type	Right or left opening Internal or external opening
• Ângulo de abertura	0° - 110°
• Opening speed (90°)	2 sec. - 4 sec.
• Closing speed (90°)	2 sec. - 4 sec.
• Pause time in opening	1 sec. - 20 sec.
• Manual strength	<30N
• Consumption	<50W
• Operating temperature	-20°C - +50°C
• Door's maximum weight	120kg
• Accessories output	500mA
• Eletric lock output	600mA

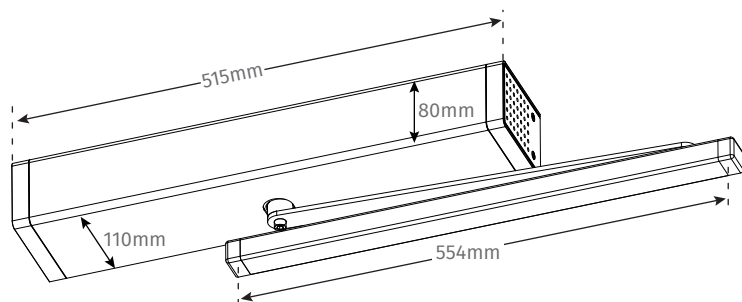

## 04. PRE-INSTALLATION

### KIT



#### KIT COMPONENTS

- Motor
- Motion shaft
- Guide with shaft
- Fixation plate



#### OPTIONAL COMPONENTS (Not included in kit)

- Radars
- 2 1.2 A Bateriae
- Push-button
- Photocells
- Remote-controls

#### REQUIRED FOR INSTALLATION:



#### WIDTH/WEIGHT RATIO

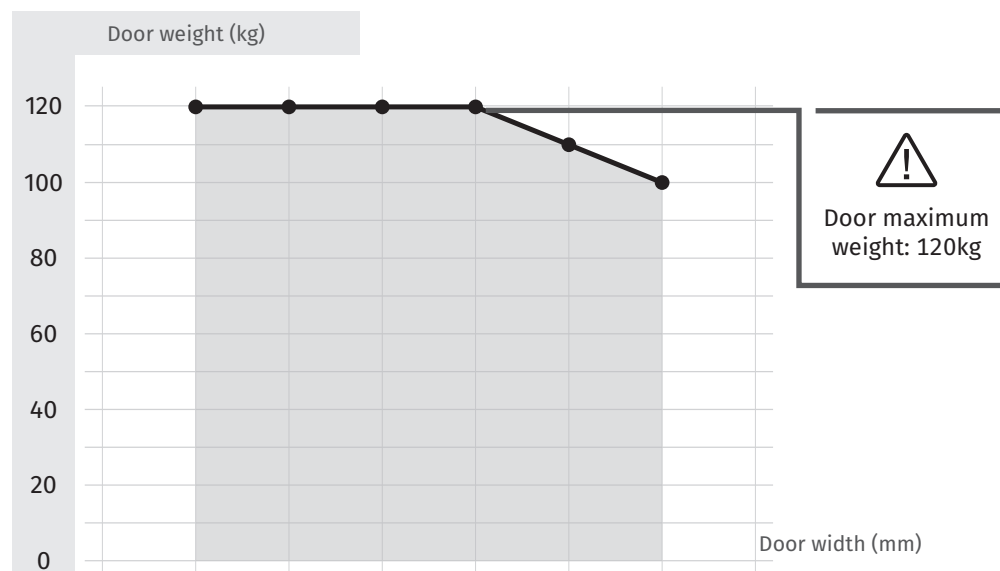

## 04. PRE-INSTALLATION

### INSTALLATION MEASURES | OPENING DIRECTION

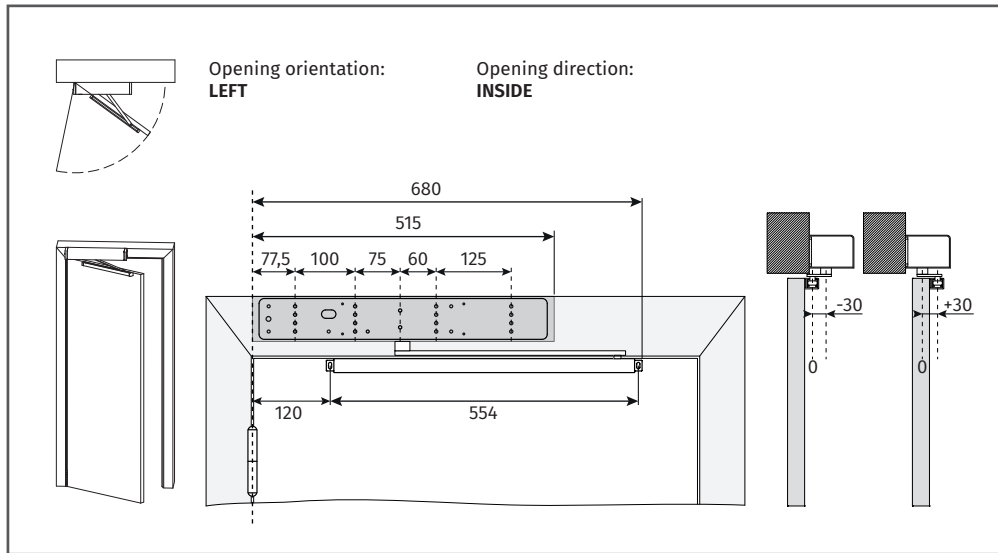

## 04. PRE-INSTALLATION

### INSTALLATION MEASURES | OPENING DIRECTION

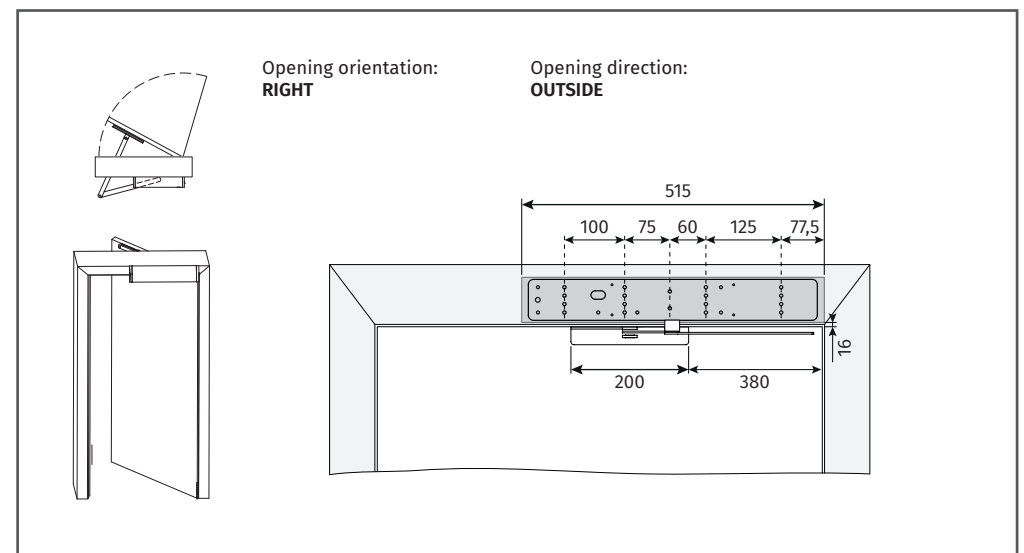
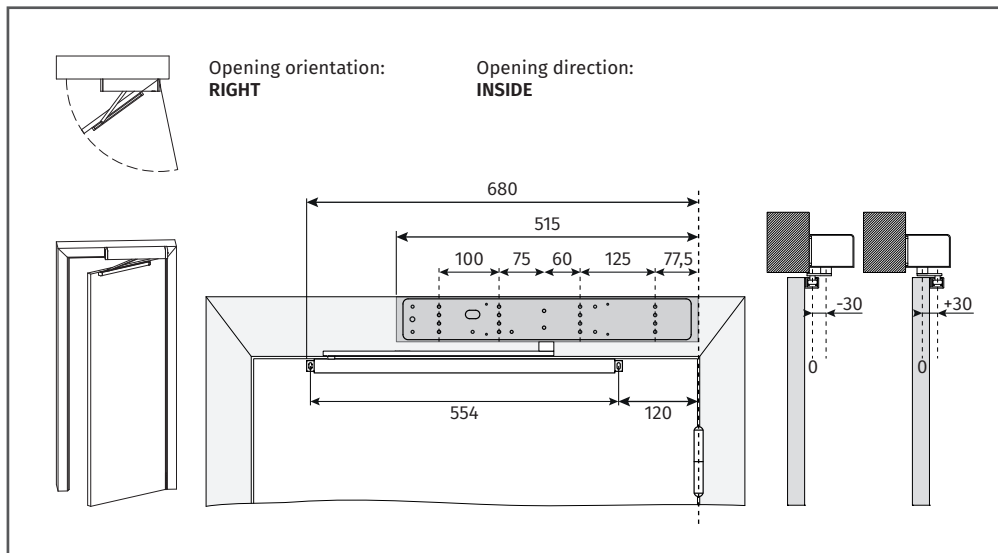
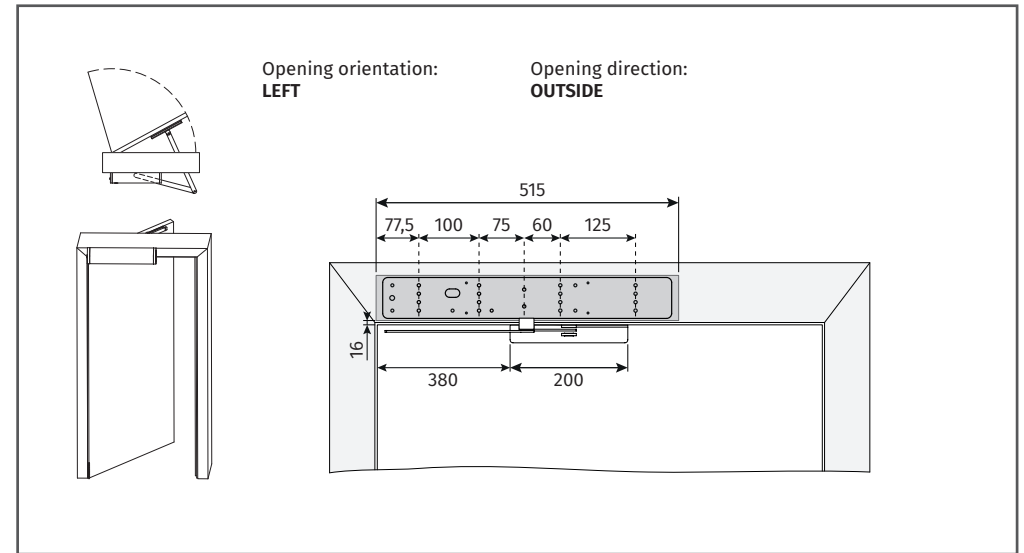

For installation of the M1805 with **opening direction inwards**, the minimum size per sheet is **680mm**.

## 05. INSTALLATION

### INSTALLATION PROCESS

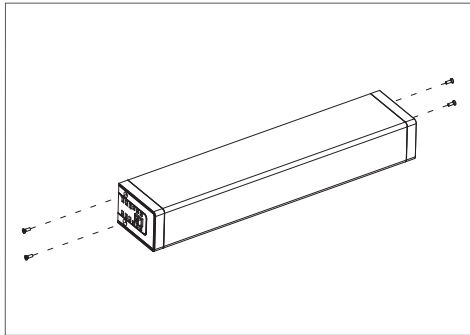

01 • Remove the 4 screws from the sides of the automation and remove the cover.

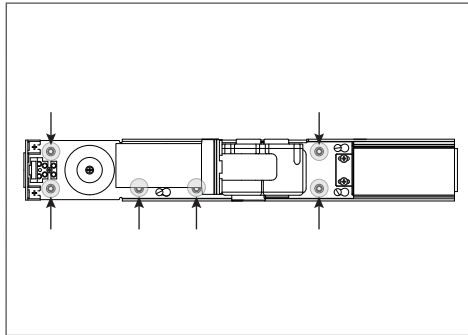

02 • Remove the 6 screws which hold the automation to the wall fixation plate.

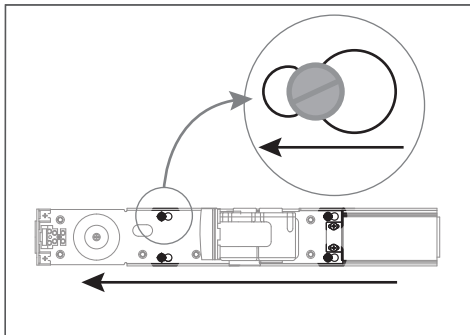

03 • Slide the automation to the left and separate it from the fixation plate.

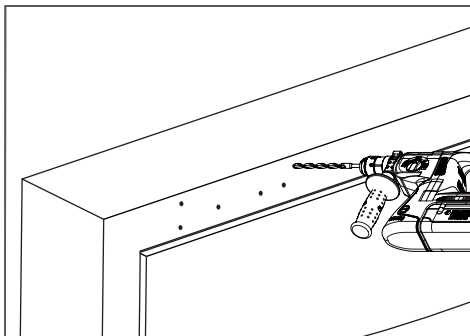

05 • Make the drillings.

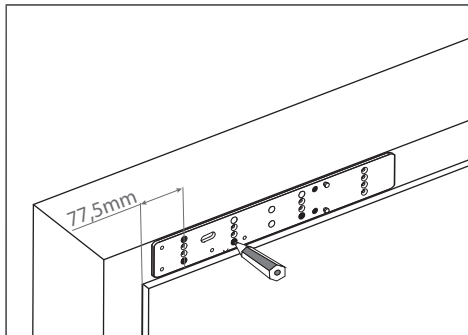

04 • Put the plate against the wall and make the markings (pay attention the measures).

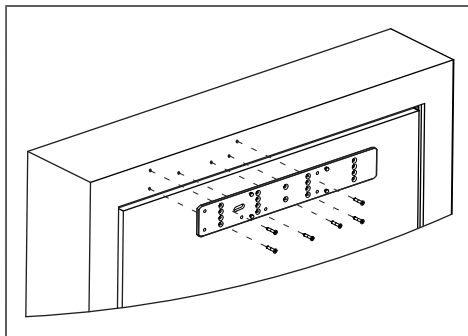

06 • Place the fixing plate directed with the holes and secure it with screws.

## 05. INSTALLATION

### INSTALLATION PROCESS

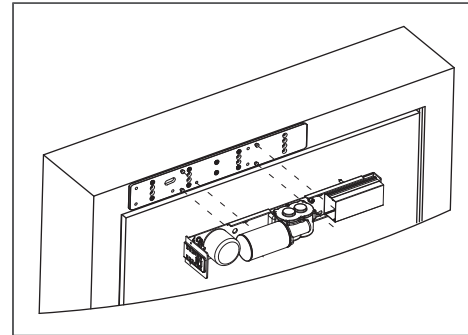

07 • Apply automation in the fixing plate and aim the screws.

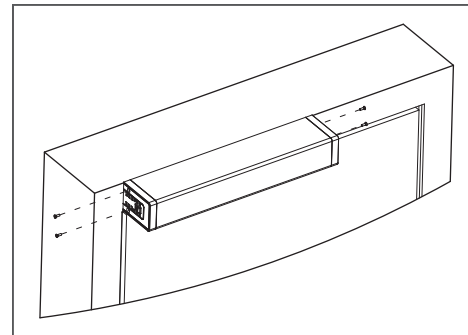

09 • Apply the cover on the automation and tighten the screws.

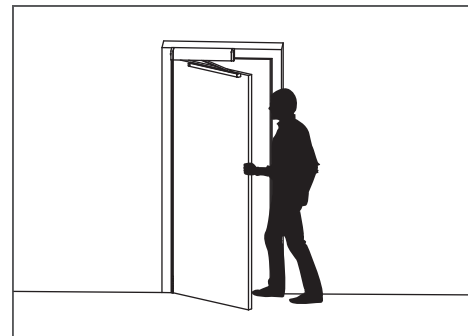

11 • Move the door manually to set the position of the opening stopper.

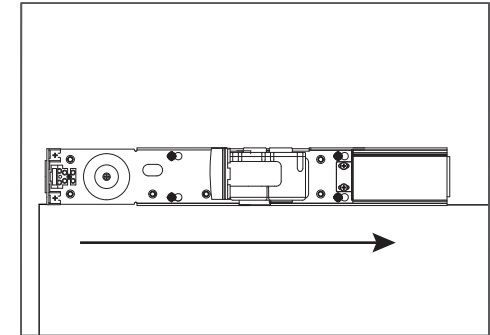

08 • Slide the automation to the right and secure it with the 6 screws.

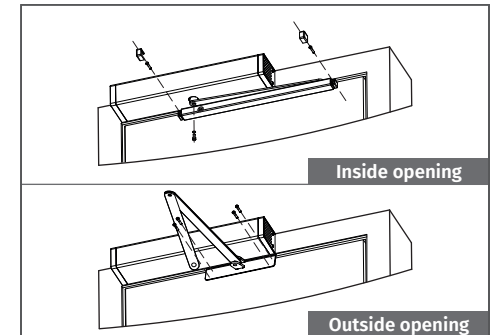

10 • Secure the arm on the automation and set the correct position of the guide to fix it in the door.

## 06. THE CONTROL BOARD

### TECHNICAL CHARACTERISTICS

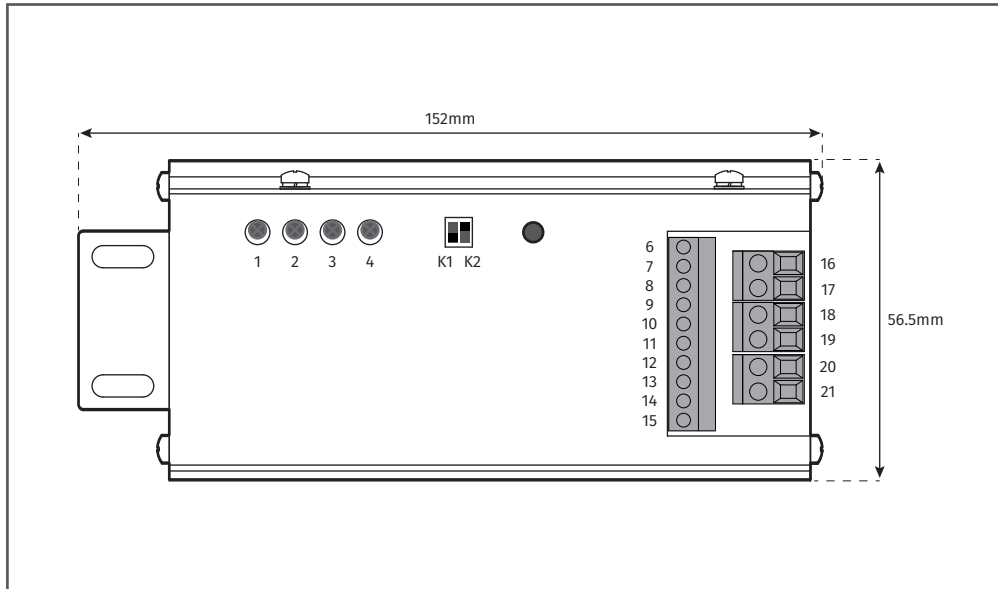

Potentiometers

- 1 • Opening speed
- 2 • Closing speed
- 3 • Delay time between motor n°1 and motor n°2 (when installed 2 motors)
- 4 • Pause time

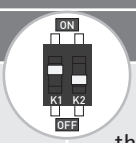
	Dippers			
	ON		OFF	
K1	<b>Magnetic lock</b> The output is continuously activated when the door is closed.		 <b>Normal lock</b> When the opening is triggered, the output receives an impulse for 3 seconds to open the latch.	
K2	Opening orientation: <b>RIGHT</b>  Opening direction: <b>INSIDE</b>	Opening orientation: <b>LEFT</b>  Opening direction: <b>OUTSIDE</b>	Opening orientation: <b>LEFT</b>  Opening direction: <b>INSIDE</b>	Opening orientation: <b>RIGHT</b>  Opening direction: <b>OUTSIDE</b>

## 06. THE CONTROL BOARD

### TECHNICAL CHARACTERISTICS

Conectores	6 • Two singular doors connection - Entrance	} Interlocking between 2 singular doors
	7 • Two singular doors connection - Exit	
	8 • Common	
	9 • <b>Photocells (Aperture)</b> - Connection (N.O) of a safety sensor for the opening. If the terminal closes during the aperture, the door will stop opening and will start to close.	
	10 • Common	
	11 • <b>Photocells (Closure)</b> - Connection (N.C) of a safety sensor for the closure. If the terminal open during closing, the door will reverse the movement.	
	12 • Common	
	13 • <b>START (P.P.)</b> - Push button to open the door (N.A).	
	14 • COM	
	15 • Empty	
	16 • Electric lock power supply output (+12V DC)	
	17 • Electric lock power supply output (-12V DC, 600mA max.)	
	 If the consumption of the electric lock is higher than that mentioned above, install a relay and an additional power supply.	
	18 • <b>Accessories power supply:</b> +15V DC, 500mA.	
	19 • <b>Accessories power supply:</b> -15V DC	
	20 • Battery input 24V (+)	
	21 • 0V. If the terminal is connected with a 24V additional battery, when the 230V AC fails, the automation will continue to operate. <b>Note</b> • With the 230V AC power supply ON, the terminal output voltage can be higher or lower than 24V.	

### PROGRAMMING

- 01 • Make sure that all connections between components and control board are made according to the manual (see the schemes in p. 4, 5 and 6).
- 02 • Before connecting to the electric current, check if there is some sort of obstacle that hinders the normal operation of the door and if the stopper is well placed.
- 03 • Put the K2 and the K1 in the desired position according to the dipper board from the page 11A.



- Before connecting the automation to the power supply, you must have the stopper installed so that the control board can recognize the course.

- 04 • Turn on the electric current. The door will have the following behavior:  
**Slowly closes → Slowly opens → Closes (to memorise the position) and stays in normal operation after finishing the cycle.**



- When the door is in normal operation, the opening angle will reduce 2 degrees therefore, it does not need to touch the stopper during all cycles.

# 07. TROUBLESHOOTING

## INSTRUCTIONS FOR FINAL CONSUMERS

## INSTRUCTIONS FOR SPECIALIZED INSTALLERS

Anomaly	Procedure	Behavior	Procedure II	Find source of the problem
• Door/Motor doesn't work	• Make sure you have a 230V power supply connected to the control board and if it is working properly.	• Still not working	• Consult a qualified MOTORLINE technician.	<ol style="list-style-type: none"> <li>1 • Open the control board and check if it has a 230V power supply;</li> <li>2 • Check the control board input fuses (switch);</li> <li>3 • If the motor does not work, remove it and send it to the MOTORLINE technical services for diagnosis.</li> </ol>
• Door/Motor doesn't move but makes noise	• Turn off the 230V power supply and move the door manually to check if there are mechanical problems.	• Found problems?	• Consult an experienced door expert.	1 • Check all axes and motion systems associated with the door and automatism (shafts, hinges, etc.) to find out what the problem is.
		• The door moves easily?	• Consult a qualified MOTORLINE technician.	1 • If the door works, the problem is in the motor. Remove it and send it to the MOTORLINE technical services for diagnosis;
• Door/Motor opens but doesn't close	• Turn off the 230V power supply and move the door manually to the closed position. Turn off the building electric board for 5 seconds and then turn on.	• The door opened but did not closed.	<ol style="list-style-type: none"> <li>1 • Check if there is any obstacle in front of the photocells;</li> <li>2 • Check if any of the door control devices (key selector and push button) are locked and are sending permanent signal to the control board;</li> <li>3 • Consult a qualified MOTORLINE technician.</li> </ol>	<p><b>A) SAFETY SYSTEMS (Security systems are opened):</b></p> <ol style="list-style-type: none"> <li>1 • Close with a shunt all control board safety systems (N.C. contacts). If the automatism starts to work normally, analyze which are the problematic devices.</li> <li>2 • Remove one shunt at a time to find out which device has the malfunction.</li> <li>3 • Swap the device with problems for a functional one and ensure that the automatism works correctly with all the other devices. If you find any more defective product, follow the same steps until discover all the problems.</li> </ol>
• Door/Motor doesn't make complete route	• Turn off the power supply and move the door manually to check if there are mechanical problems.	• Found problems?	• Consult an experienced door expert.	1 • Check all axes and motion systems associated with the door and automatism (shafts, hinges, etc.) to find out what the problem is.
		• The door moves easily?	• Consult a qualified MOTORLINE technician.	<ol style="list-style-type: none"> <li>1 • Make a new programming course in control board attributing the necessary times to open and close with appropriate force.</li> <li>2 • If that does not work, remove the control board and send it to the MOTORLINE technical services for diagnosis.</li> </ol> <p><b>NOTE:</b> The control board strength must be sufficient to open and close the door without stopping, but a person must be able to stop it with small effort. In case of safety systems failure, the door will never cause physical damage to the obstacles (vehicles, people, etc.).</p>