

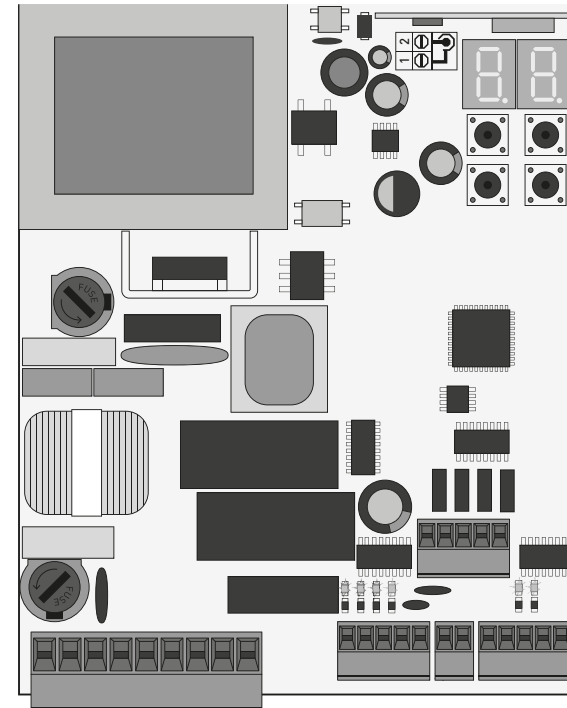

MC50SC

USER/INSTALLER MANUAL



01. SAFETY INSTRUCTIONS

STANDARDS TO FOLLOW _____ 3A

02. THE CONTROL BOARD

TECHNICAL SPECIFICATIONS _____ 3B

PROGRAMMING PRE-RECOMENDATIONS _____ 4A

03. INSTALLATION

ESSENTIAL STEPS FOR INSTALLATION _____ 5A

TRANSMITTERS _____ 5B

"P" MENU FUNCTIONS _____ 6A

"E" MENU FUNCTIONS _____ 6B

04. PROGRAMMING (P)

P0-AUTOMATIC PROGRAMMING OF THE COURSE _____ 7A

P0-SEMI-AUTOMATIC PROGRAMMING OF THE COURSE _____ 7B

P1-SETTING THE DECELERATION TIME _____ 8A

P2-SETTING STRENGTH AND SENSITIVITY _____ 9

P3-PEDESTRIAN COURSE TIME _____ 10A

P4-PAUSE TIME _____ 10B

P5-PHOTOCELLS PROGRAMMING _____ 11A

P6-SAFETY BAND _____ 11B

P7-OPERATING LOGIC _____ 12A

P8-FLASHING LIGHT _____ 12B

P9-DISTANCE PROGRAMMING _____ 13A

05. PROGRAMMING (E)

E0-PRESENT MAN _____ 13B

E1-SOFT START _____ 14A

E2-COURTESY LIGHT TIME _____ 14B

E3-FOLLOW ME _____ 15A

E5-ELECTRIC BRAKE _____ 15B

E6-DECELERATION SPEED _____ 16A

E7-MANEUVERS COUNTER _____ 16B

E8-RESET - RESTORE FACTORY VALUES _____ 17A

E9-RGB FLASHING LIGHT _____ 17B

06. DISPLAY

DISPLAY INDICATIONS _____ 18A

07. COMPONENTS TEST

INPUTS TEST _____ 18A

CAPACITOR SCHEME _____ 18B

08. TROUBLESHOOTING

INSTRUCTIONS FOR FINAL CONSUMERS/ TECHNICIANS _____ 19

09. CONNECTION SCHEME

CONNECTIONS MAP _____ 20

ATTENTION:

| | |
|---|--|
|  | This product is certified in accordance with European Community (EC) safety standards. |
| RoHS | This product complies with Directive 2011/65/EU of the European Parliament and of the Council, of 8 June 2011, on the restriction of the use of certain hazardous substances in electrical and electronic equipment. |
|  | (Applicable in countries with recycling systems). This marking on the product or literature indicates that the product and electronic accessories (eg. Charger, USB cable, electronic material, controls, etc.) should not be disposed of as other household waste at the end of its useful life. To avoid possible harm to the environment or human health resulting from the uncontrolled disposal of waste, separate these items from other types of waste and recycle them responsibly to promote the sustainable reuse of material resources. Home users should contact the dealer where they purchased this product or the National Environment Agency for details on where and how they can take these items for environmentally safe recycling. Business users should contact their vendor and check the terms and conditions of the purchase agreement. This product and its electronic accessories should not be mixed with other commercial waste. |
|  | |
|  | This marking indicates that the product and electronic accessories (eg. charger, USB cable, electronic material, controls, etc.) are susceptible to electric shock by direct or indirect contact with electricity. Be cautious when handling the product and observe all safety procedures in this manual. |

- It is important for your safety that these instructions are followed.
- Keep these instructions in a safe place for future reference.
- The **ELECTROCELOS S.A.** is not responsible for the improper use of the product, or other use than that for which it was designed.
- The **ELECTROCELOS S.A.** is not responsible if safety standards were not taken into account when installing the equipment, or for any deformation that may occur.
- The **ELECTROCELOS S.A.** is not responsible for insecurity and malfunction of the product when used with components that were not sold by the them.
- This product was designed and manufactured strictly for the use indicated in this manual.
- This control board is not appropriate for inflammable or explosive environments.
- Any other use not expressly indicated may damage the product and/or can cause physical and property damages, and will void the warranty.
- Do not make any changes to the automation components and/or their accessories.
- Control board for indoor use with 230V connection.
- Keep remote controls away from children, to prevent the automated system from being activated involuntarily.
- The customer shall not, under any circumstances, attempt to repair or tune the automatism. Must call qualified technician only.
- The installer must have certified professional knowledge at the level of mechanical assemblies in doors and gates and control board programming. He should also be able to perform electrical connections in compliance with all applicable regulations.
- The installer should inform the customer how to handle the product in an emergency and provide him the manual.

The MC50SC is a monophasic control board com a control system via incorporated rádio, developed for the automation of sliding gates.

| | |
|--------------------------------|---|
| • Power supply | 230V AC 50-60Hz |
| • Lightbulb's output | 230V AC 50Hz 100W max. |
| • RGB Lightbulb's output | 24V DC 100mA max. |
| • Motor's output | 230V AC 50-60Hz 1000 W max. |
| • Auxiliary accessories output | 24V DC 8 W max. |
| • Security and BT transmitters | 24V DC |
| • Working temperature | -25°C to + 55°C |
| • Incorporated Radio Receptor | 433,92 Mhz |
| • OP Transmitters | 12bits or Rolling Code |
| • Maximum Memory Capacity | 100 (full opening) - 100 (pedestrian opening) |
| • Control board Dimensions | 105x130 mm. |

• CONNECTOR'S DESCRIPTION

| | |
|-----|---|
| CN1 | <ul style="list-style-type: none"> 01 • Grounding 02 • Grounding 03 • 230V Line Input (phase) 04 • 230V Line Input (neutral) 05 • 230V Motor's Output – Opening 06 • 230V Motor's Output – Common 07 • 230V Motor's Output - Closing 08 • AC 230V Lightbulb Output 09 • AC 230V Lightbulb Output |
| CN2 | <ul style="list-style-type: none"> 01 • Pedestrian Push input 02 • Total Push input 03 • Motor's opening limit-switch input (OPEN) 04 • Motor's closing limit-switch input (CLOSE) 05 • Common |
| CN3 | <ul style="list-style-type: none"> 01 • 24V DC 200mA max power supply 24V 02 • 24V DC 200mA max power supply (↓) |

CN4
01 • Safety Edge
02 • Photocells
03 • Encoder (not used)
04 • Encoder (not used)
05 • Common

CN5
01 • +24V DC Auxiliary Power Supply for LED RGB flashing light
02 • Y output
03 • R output
04 • G output
05 • B output

To enhance knowledge about the control board operation, before proceeding to the setup, give special attention to the instructions that follow.

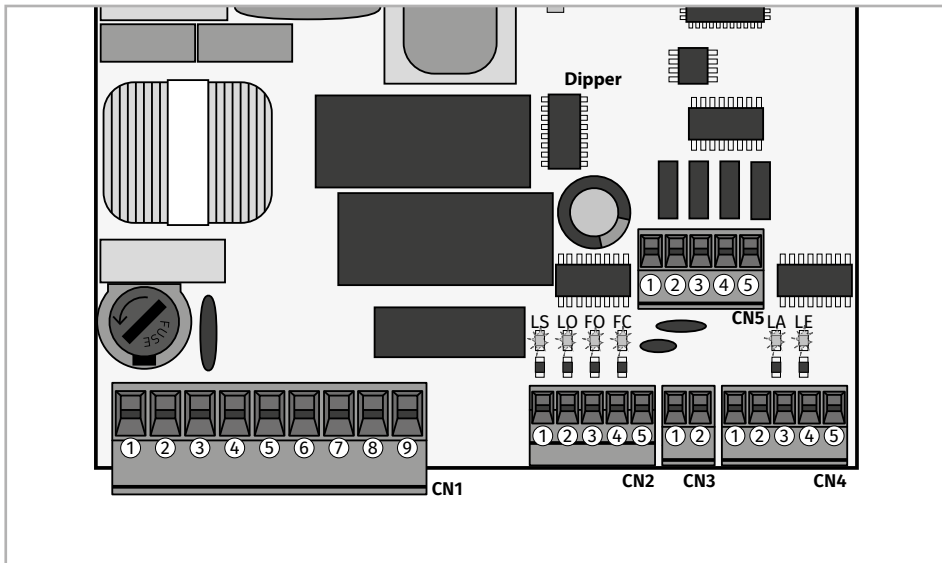

LEDS
LS • LED lit when the pedestrian push button is active
LO • LED lit when the total push button is active
FO • LED off when the opening limit switch is active
FC • LED off when the closing limit switch is active
LA • LED off when safety edge is active (when **P6** is active)
LE • LED off when photocells are active (when **P5** is active)

CN1
Courtesy light or flashing light:
08 and **09** • This output allows connection of a courtesy light or a flashing light (see **P8** in page 12B).

CN2
Limit switches:
03 and **04** • The control board needs a opening and closing limit-switches connection (both in NC). Triggering any limit-switch will make the immediate stoppage of the movement. The limit-switch thriggering is visible on the display. OP (opening limit switch activated) and CL (opening limit switch activated). It is mandatory the use of limit switches.

CN4
Safety circuits:
01 • This input allows connection of safety bands. The device operates according to programming set in the **P6** menu (**page 11B**)
02 • This input allows connection of photocells. The device operates according to programming set in the **P5** menu (**página 11A**)
 Shunt application is not necessary.

CN5
01 • Auxiliary output for flashing light or 24V DC LED.
 Open collector for the management of auxiliary functions:
02 • The Y output is activated in intermittent mode, only with the closed gate.
03 • The R output is activated in intermittent mode, only in closing phase.
04 • The G output is activated in intermittent mode, only in opening phase.
05 • The B output is activated in intermittent mode, only in pause time.

Dipper
 The dipper indicates which motor is connected to the control board.

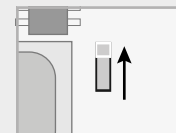

Put the dipper in this position when using motors with power < 500 watts

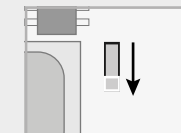

Put the dipper in this position when using motors with power > 500 watts



The installation process assumes that the gate has already limit switches plates installed. For more information consult the motor's manual.

01 • Make the connections of all the accessories according to the connection scheme (page 20).

02 • Connect the control board to a 230V power supply (3 and 4 - CN1 terminals).

03 • Make sure that the gate movement is the same as the one shown on the display:

| | | |
|-----------|-----------|--|
| CL | OP |  <p>If the display does not match the gate's movement, turn off the control board from the power supply e swap the 5 and 7 wires from CN1 and check if it is correct with 3 and 4 from CN2.</p> |
| CLOSING | OPENING | |

04 • Check is the limit switches, so that the FC LED turns off during the closure and the LED FO turns off during the opening.

05 • Make an automatic programming - **P0** menu (page 7A).

06 • If necessary, adjust the gate of the deceleration time in opening and closing - **P1** menu (page 8A).

07 • Adjust the strength and sensitivity of the motor - **P2** menu (page 9).

08 • Make an automatic programming of the course again - **P0** menu (page 7A).

09 • Enable or disable the use of photocells in the **P5** menu (page 11A).

10 • Enable or disable the use of safety band in the **P6** menu (page 11B).

11 • Program a transmitter (page 5B).

The control board is now fully configured!

Check the menus from the programming pages in case you wish to configure other features of the plant.

SU Transmitter programming for total opening.

SP Transmitter programming for pedestrian opening.

• PROGRAMMING TRANSMITTERS

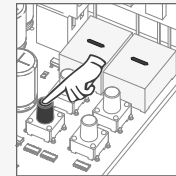

01 • Press the cmd button for 1 sec.

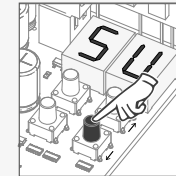

02 • Select the function where you want to program the transmitters (SU and SP) using ↓ ↑.

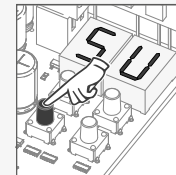

03 • Press cmd once to confirm the function (SE or SP).

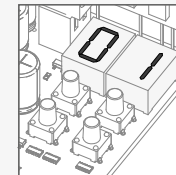

04 • The first free position appears.



05 • Press the command button you want to program. The display will blink and move to the next free location.

• ERASE TRANSMITTERS

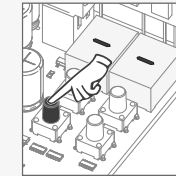

01 • Press the cmd button for 1 sec.

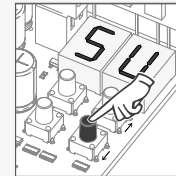

02 • Select the function (SU or SP) using ↓ ↑.

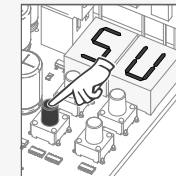

03 • Press cmd once to confirm the function (SU or SP).

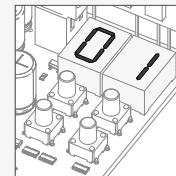

04 • Use ↓ ↑ to select the transmitter location you want to delete.

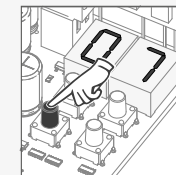

05 • Press cmd for 3sec. and the position is empty. The display will flash and the position will be available.

• ERASE ALL THE TRANSMITTERS



01 • Press the cmd button for 5 sec.

02 • The display will show **dL**, confirming that all transmitters have been erased.



• Whenever you store or delete a command, the display will flash and show the next position. You can add or delete commands without having to go back to point 01.



• If you do not press any key for 10 sec. the control board will return to standby.

• We can only go into programming with a electrically closed gate.

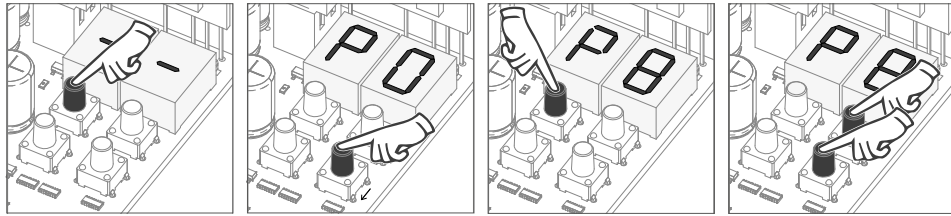

- To access the P menu • Use ↓ ↑ to navigate through the menus.
- Press MENU when you want to confirm access to a menu.
- Press ↓ ↑ simultaneously to exit programming.

| MENU | FUNCTION | MAX. MIN. PROGRAMMABLE | STATE | FACTORY VALUE | PAGE |
|------|----------------------------------|------------------------|---|----------------|------|
| P0 | Course automatic programming | - | P! Automatic programming !R Semi-automatic programming | - | 7A |
| P1 | Deceleration time adjustment | | ⋈P Deceleration time dR Opening deceleration dF Closing deceleration | 00 03 03 | 8A |
| P2 | Force and sensibility adjustment | min. 1 max. 9 | FD Force adjustment F5 Sensibility adjustment Fd sens. adjustment in deceleration | 06 00 00 | 9 |
| P3 | Pedestrian Course time | min. 0s max. 50s | Fd Time adjustment in pedestrian mode | 10 sec | 10A |
| P4 | Pause time | min. 1s max. 99s | RF Total closure pause time adjustment RP Pedestrian closure pause time adjustment | 10 sec | 10B |
| P5 | Photocells programming | - | HE 00 photocells Disabled 01 photocells Activated HC 00 Photocells in closing 01 Photocells in opening | 00 00 | 11A |
| P6 | Safety band | - | HE 00 Security Band Disabled 01 Security Band Activated HR 00 8k2 input 01 NC input HL 00 Band in closure 01 Band in opening | 00 01 00 | 11B |
| P7 | OperatiNG logic | - | 00 Automatic mode function 01 Step by step mode function 02 Mode condominium function | 00 | 12A |
| P8 | Flashing light | - | 00 Flashing (opening and closing) 01 Step by step mode function 02 Courtesy light | 00 00 00 | 12B |
| P9 | Distance programming | - | 00 Distance PGM OFF 01 Distance PGM ON | 00 | 13A |

• We can only go into programming with a electrically closed gate.

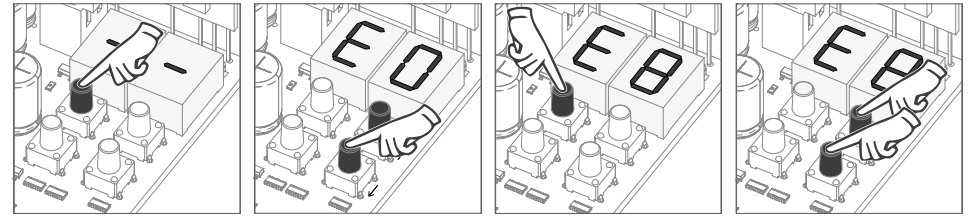

- To access the E menu • Use ↓ ↑ to navigate through the menus.
- Press MENU when you want to confirm access to a menu.
- Press ↓ ↑ simultaneously to exit programming.

| MENU | FUNCTION | MÁX. MIN. PROGRAMMABLE | STATE | FACTORY VALUE | PAGE |
|--------------------|---|------------------------|---|---------------|------|
| E0 | Present Man | - | HP 00 Deactivates present man 01 Activates present man PL 00 Disables push buttons mode 01 Enables push buttons mode | 00 01 | 13B |
| E1 | Soft start | - | 00 Deactivates Soft start 01 Activates Soft start | 00 | 14A |
| E2 | Courtesy light time | min. 0 max. 99 | Courtesy light time adjustment | 00 | 14B |
| E3 | Follow me | - | 00 Deactivates follow me 01 Activates follow me | 00 | 15A |
| E5 | Electric brake | - | 00 Deactivates electronic brake 01 Activates electronic brake | 00 | 15B |
| E6 | Deceleration speed | min. 1 max. 9 | Deceleration speed adjustment | 05 | 16A |
| E7 | Operation counter | - | Shows the number of maneuvers | - | 16B |
| E8 | Reset - Restore factory settings | - | 00 Deactivated 01 Reset activated | 00 | 17A |
| E9 | RGB Output | - | 00 Continued output 01 Intermittent output | 01 | 17B |
| TRANSMITTER | | | | | |
| SU | Transmitter programming for total opening. | | | | 5B |
| SP | Transmitter programming for pedestrian opening. | | | | 5B |

AU

This menu allows automatic programming of the motor and deceleration.

During automatic programming, the motor will perform the following maneuvers:

- 1º Slowly close the gate until it reaches the end of the closing course
- 2º Slowly opens for aabout 10 seconds
- 3º Slowly closes until it reaches the limit switch
- 4º The gate opens at normal speed until it reaches the limit switch
- 5º The gate closes at normal speed until it reaches the limit switch



Steps 2 and 3 are only made if P2-dF is set to a value equal to or greater than 1.
If P2-dF is set to 0 (zero), you will only do steps 1, 4, and 5.

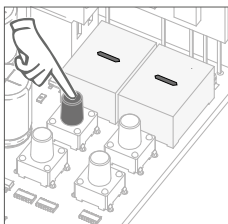

01 • Press MENU for 3 seconds.

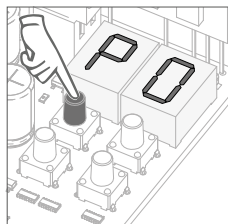

02 • P0 appears. Press MENU for 1 second.

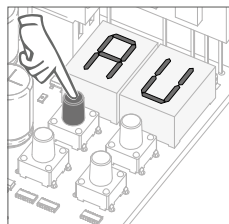

03 • AU appears. Press MENU for 1 second to start automatic programming.

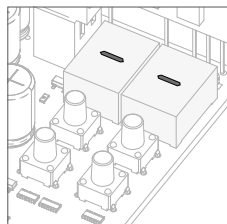

04 • When programming is complete, the display returns to the initial state (--).

7A

This submenu performs a semi-automatic programming of the working time of the motor, setting the slow speed areas manually.

To do this, you must press MENU at the moment you want to start the soft stop (slow speed), both in the opening and closing phases.



If you do not press MENU at any time, an automatic programming will be performed without any deceleration.

This programming can be done without limit switches, but it is mandatory to press MENU whenever the door reaches the end of each course.

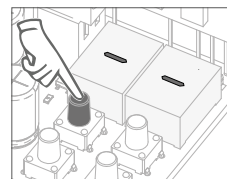

01 • Press MENU for 3 seconds.

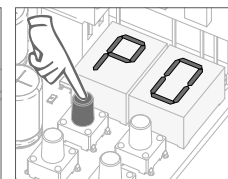

02 • P0 appears. Press MENU for 1 second.

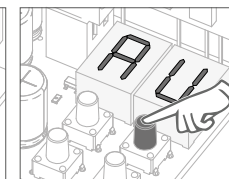

03 • AU appears. Press ↑ 1 time to show MA.

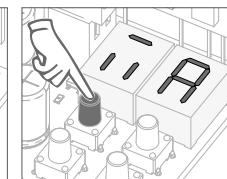

04 • When MA appears, press MENU for 1 second. The motor will start a slow closing of the door.

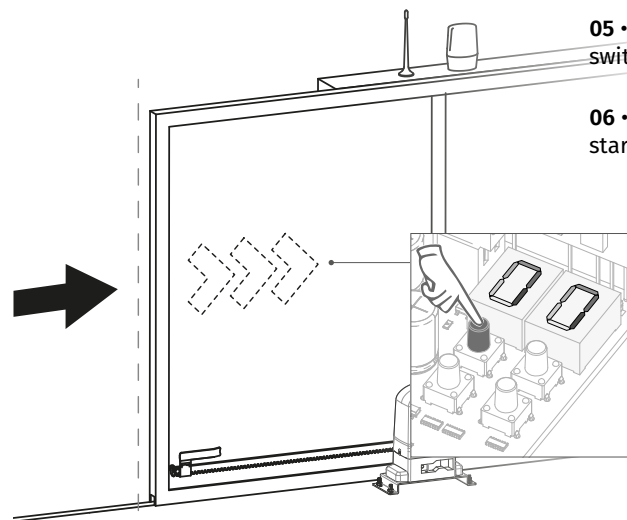

05 • When it reach the closing limit switch, it will open automatically.

06 • Press MENU when you want to start the opening deceleration.

07 • When you reach the limit switch, it will automatically close.

08 • Press MENU when you want to start the closing deceleration.

tP

Deceleration type

It allows to set the slowdown speed, according to the automation power.



When the deceleration is not used, you must adjust the limit switches to be activated slightly before the desired location for the gate to stop. This will ensure that the gate does not exceed the stopping point due to movement inertia, which could cause it to get stuck.

Function 00

Suitable for smaller power engines and light gates, it has a smoother movement during the deceleration and allows to change the speed in the E6 menu.

Funktion 01

Suitable for engines with higher power and heavy gates, this type of deceleration is stronger, and can generate some vibration. Does not allow to change the speed in E6!



NOTE: Always set this menu to a value of 00. If the gate does not operate properly during the deceleration, change to 01 to use a stronger deceleration.

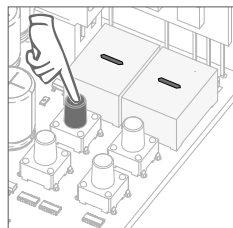

01 • Press MENU for 3 seconds.

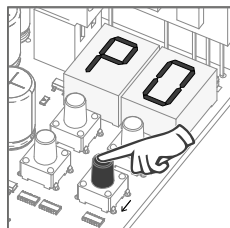

02 • P0 appears. Press ↓ 1 time.

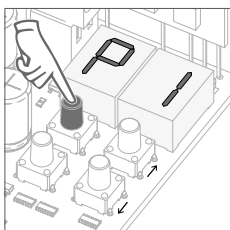

03 • P1 appears. Press MENU for 1 second.

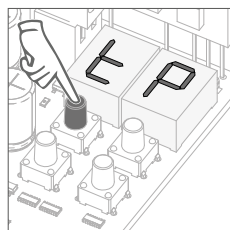

04 • tP appears. Press MENU for 1 second.

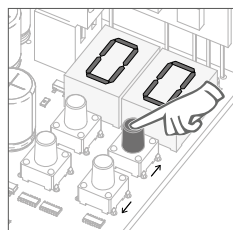

05 • The factory set value is displayed. If desired, change the time to 01 using ↓.

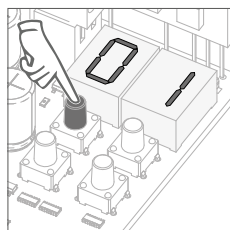

06 • Press MENU for 1 second to save the set value.

dA

Opening deceleration

It allows to define the slowdown time in the opening phase.

dF

Closing deceleration

It allows defining the slowdown time in the closing phase.



When the deceleration is not used, you must adjust the limit switches to be activated slightly before the desired location for the gate to stop. This will ensure that the gate does not exceed the stopping point due to movement inertia, which could cause it to get stuck.

min. max. (factory default 3)

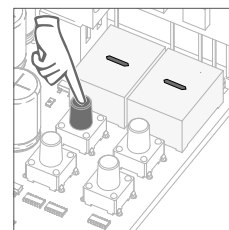

01 • Press MENU for 3 seconds.

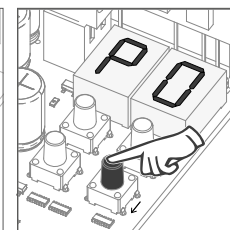

02 • P0 appears. Press ↓ 1 once.

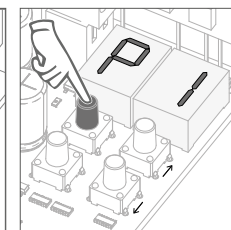

03 • P1 appears. Press MENU for 1 second.

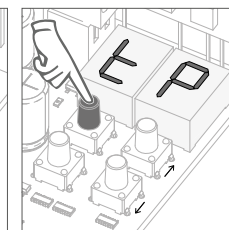

03 • tP appears. Press MENU for 1 second.

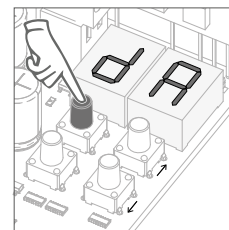

04 • dA appears. Press MENU for 1 second.

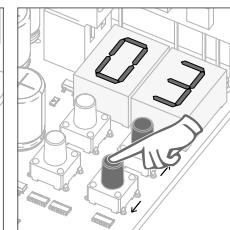

05 • Appears the time defined from factory. If you want, change the time from 1 to 15 sec. using ↑ ↓.

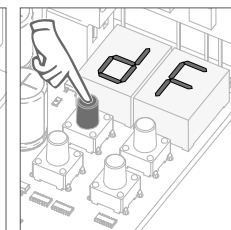

06 • Press MENU for 1 second, to save the defined time. dF appears. Press MENU for 1 second.

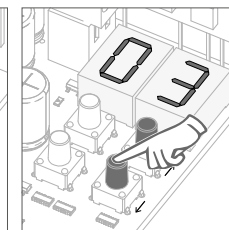

08 • Appears the time defined from factory. If you want, change the time from 1 to 15 sec. using ↑ ↓.

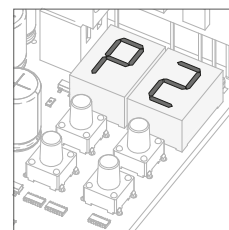





09 • Press MENU to save the chosen time. P2 appears. To program P2, continue in step 3 from P2 menu (page 9). To exit the programming press ↓ ↑ simultaneously.

If you set the sensitivity (FS) to a value greater than 1, the force (FO) is automatically set to 9

without the possibility to change it.

Note: If the control board has very high sensitivity values, you may see the LI error. After four attempts, the LI error will turn ER.

You will have to wait 10 sec. to return to program the automatism.

| | | |
|--|--|--|
| FO |  <p>The control board is supplied with this function disabled. To activate the function, you must make a new programming of the course. This will allow the control board to assume new settings.</p> | |
| <p>Strength adjustment It allows to regulate the motor's operation force when opening and closing.</p> | | |
| | FS | Fd |
| | <p>Sensitivity adjustment It allows you to adjust the engine sensitivity in detecting obstacles. The higher the sensitivity the less effort is needed to detect any obstacle and reverse the direction.</p> | <p>Deceleration sensitivity adjustment It allows you to adjust the sensitivity during the deceleration.</p> |
|  min. 1 max. 9 (Factory default 06) |  min. 1 max. 9 (Factory default 00) |  min. 1 max. 9 (Factory default 00) |

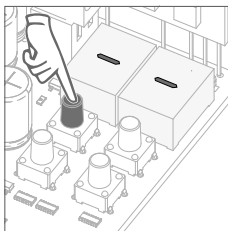

01 • Press MENU for 3 seconds.

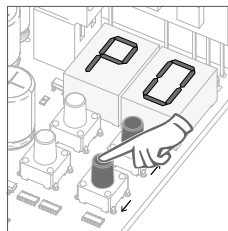

02 • P0 appears. Press ↓ twice.

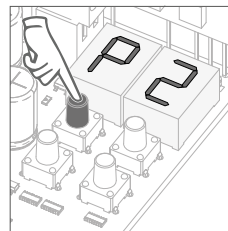

03 • P2 appears. Press MENU for 1 second.

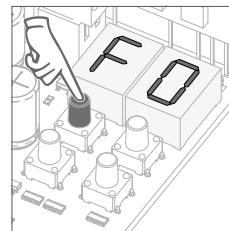

04 • F0 appears. Press MENU for 1 second.

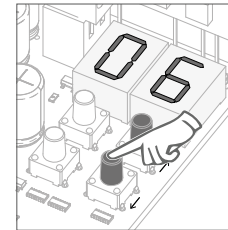

05 • Appears the value defined from factory. If you want, change the value from 1 to 9 using ↓ ↑.

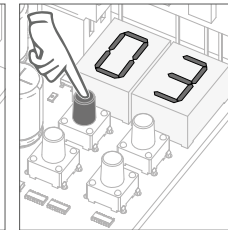

06 • Press MENU for 1 second, to save the defined value.

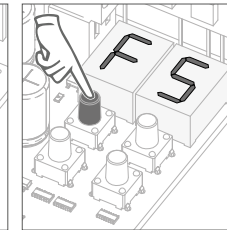

07 • FS appears. Press MENU for 1 second.

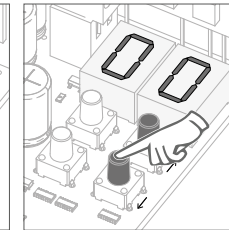

08 • Appears the value defined from factory. If you want, change the value from 1 to 9 using ↓ ↑.

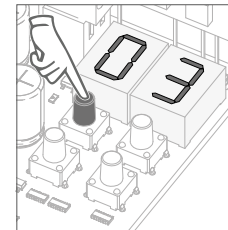

09 • Press MENU for 1 second, to save the defined value.

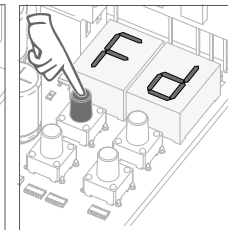

10 • Fd appears. Press MENU for 1 second.

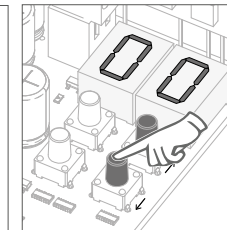

11 • Appears the value defined from factory. If you want, change the value from 1 to 9 using ↓ ↑.

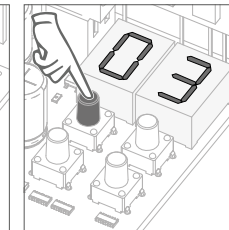

12 • Press MENU for 1 second, to save the defined value.

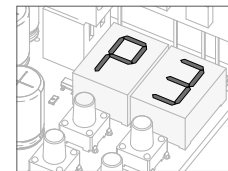

13 • P3 appears. To program P3, continue in step 3 from P3 menu (page 10A). To exit the programming press ↓ ↑ simultaneously.

The pedestrian mode allows the gate to open for the passage of people without the need to fully open.
This function can set the time you want the gate to open.

⚠ In order to the pedestrian mode to work, it is necessary that the minimum working time is 1 second, because 0 disables the function.

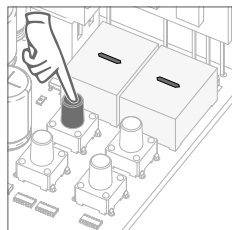

01 • Press MENU for 3 seconds.

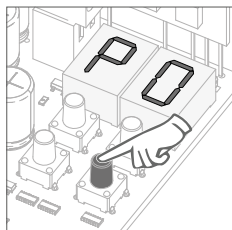

02 • P0 appears.
Press ↓ three times.

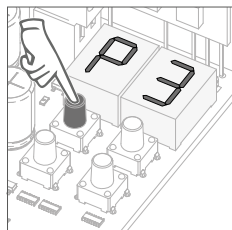

03 • P3 appears.
Press MENU for 1 second.

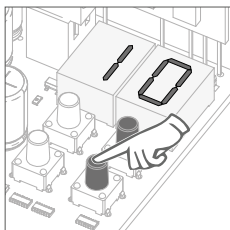

04 • Appears the time set from factory. If you want, change time between 1 and 99 sec., using ↓ ↑.

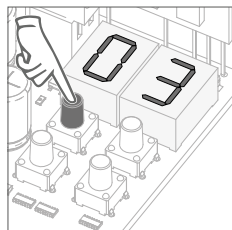

05 • Press MENU to save the defined time.

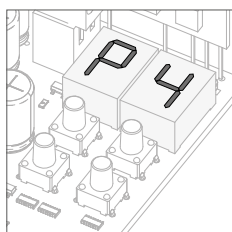

06 • P4 appears.
To program P4, continue in step 3 from P4 menu (page 10B).
To exit the programming press ↓ ↑ simultaneously.

AF

Pause time adjustment of the total closure
Allows you to set the time that the gate will remain open.



AP

Pause time adjustment of the pedestrian closure
Allows you to set the time that the gate will remain open in pedestrian mode.



When the values are zero, the automatic closing ceases to exist

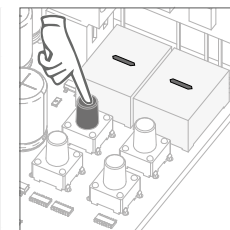

01 • Press MENU for 3 seconds.

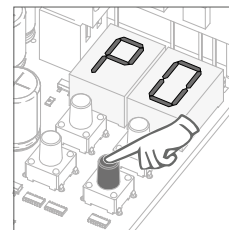

02 • P0 appears.
Press ↓ four times.

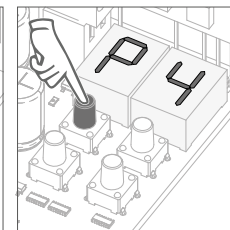

03 • P4 appears.
Press MENU for 1 second.

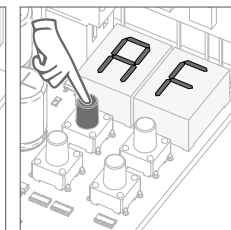

04 • AF appears.
Press MENU for 1 second.

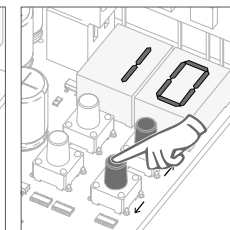

05 • Appears the time set from factory. If you want, change time between 1 and 99 sec., using ↓ ↑.

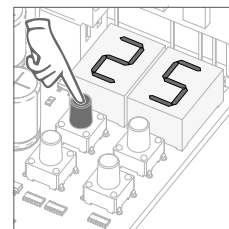

06 • Press MENU for 1 second to save the defined time.

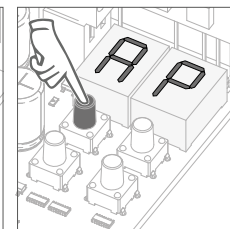

07 • AP appears.
Press MENU for 1 second.

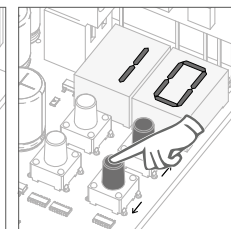

08 • Appears the time set from factory. If you want, change time between 1 and 99 sec., using ↓ ↑.

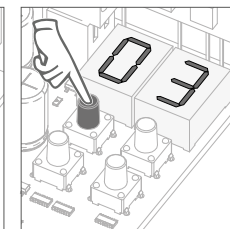

09 • Press MENU for 1 second to save the defined time.

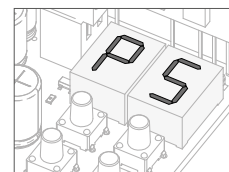

10 • P5 appears.
To program P5, continue in step 3 from P5 menu (page 11A).
To exit the programming press ↓ ↑ simultaneously.

| HE | HC |
|---|---|
| <p>00 (disables photocells) 01 (ables photocells) With the photocells activated, when someone interrupts them, the gate reverses the direction set in HC.</p> | <p>00 (photocells during the closing) 01 (photocells during the opening) This menu can only be changed when the HE menu is active. 00 - photocell only intervenes during closure and reverses in full 01 - photocell only intervenes in opening and reverses for 2 sec.</p> |
| (factory default 00) | (factory default 00) |

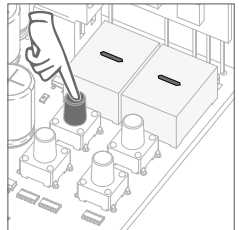

01 • Press MENU for 3 seconds.

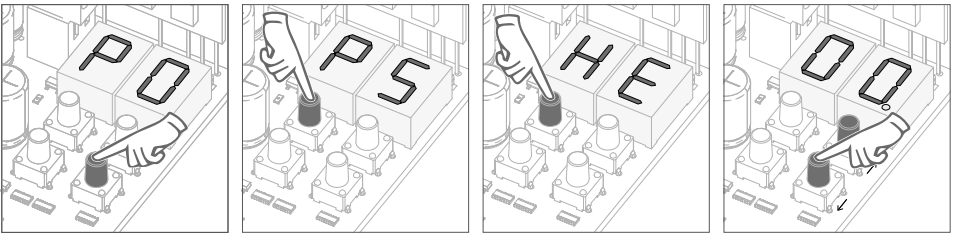

02 • P0 appears. Press ↓ five times.
 03 • P5 appears. Press MENU for 1 second.
 04 • HE appears. Press MENU for 1 second.
 05 • Appears the function set from factory. If you want, change the it between 00 and 01 using ↓ ↑.

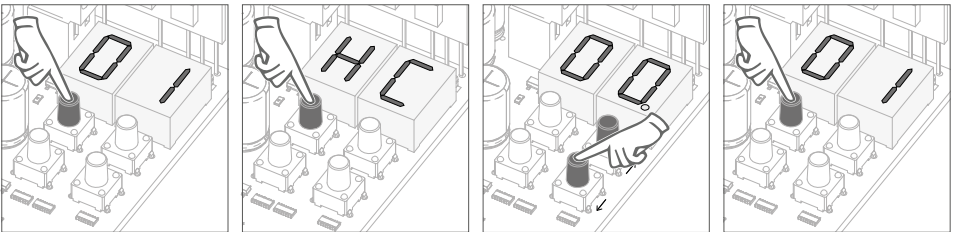

06 • Press MENU for 1 seconds to confirm the defined function.
 07 • HC appears. Press MENU for 1 second.
 08 • Appears the function set from factory. If you want, change the it between 00 and 01 using ↓ ↑.
 09 • Press MENU for 1 seconds to confirm the defined function.

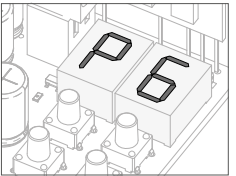

10 • P6 appears. To program P6, continue in step 3 from P6 menu (page 11B). To exit the programming press ↓ ↑ simultaneously.

| HE | HA | HL |
|--|--|---|
| <p>00 (disables safety band) 01 (ables safety band) The menu allows you to enable/disable its operation.</p> | <p>00 (8k2 input) 01 (NC input) You can only program HA if it has HE enabled (page 9A). Therefore, you can choose safety band with 8k2 resistive type (00) or safety band with normally closed contact, NC (01).</p> | <p>00 (band during closure) 01 (band during opening) You can only program HA if it has HE enabled (page 9A) and after choose the type of safety band in HA. In closure (00) the door reverses, in opening (01) reverses only 2 seconds.</p> |
| (factory default 00) | (factory default 01) | (factory default 00) |

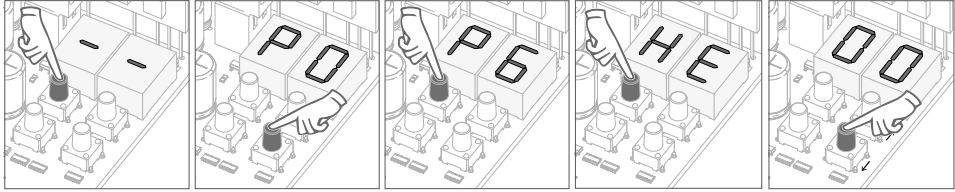

01 • Press MENU for 3 seconds.
 02 • P0 appears. Press ↓ six times.
 03 • P6 appears. Press MENU for 1 second.
 04 • HE appears. Press MENU for 1 second.
 05 • Appears the function set from factory. If you want, change the it between 00 and 01 using ↓ ↑.

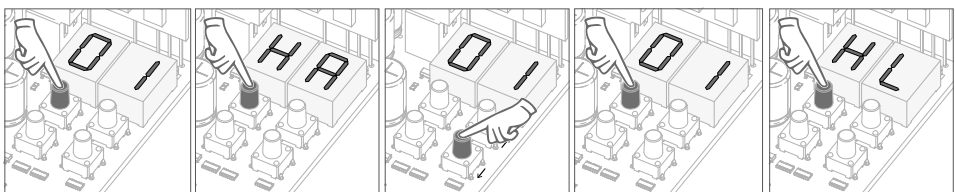

06 • Press MENU for 1 second to confirm the defined function.
 07 • HA appears. Press MENU for 1 second.
 08 • Appears the function set from factory. If you want, change the it between 00 and 01 using ↓ ↑.
 09 • Press MENU for 1 second to confirm the defined function.
 10 • HL appears. Press MENU for 1 second.

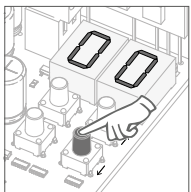

11 • Appears the function set from factory. If you want, change the it between 00 and 01 using ↓ ↑.

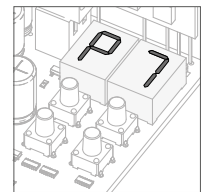

12 • Press MENU for 1 second to confirm the defined function. P7 appears. To program P7, continue in step 3 from P7 menu (page 12A). To exit the programming press ↓ ↑ simultaneously.

This menu allows you to set the gate's operating mode.

| 00 | 01 | 02 |
|--|---|--|
| Functioning in automatic mode 1st impulse - OPENS 2nd impulse - STOPS, TIMER AND CLOSES (IF P4>00) 3rd impulse - INVERTS | Functioning in step by step mode 1st impulse - OPENS 2nd impulse - STOPS 3rd impulse - CLOSES 4th impulse - STOPS If is fully open and timed, the gate closes factory default (00) | Functioning in condominium mode Does not accept orders during opening and pause time, in closure it reverses (either by transmitter or control board start button) |

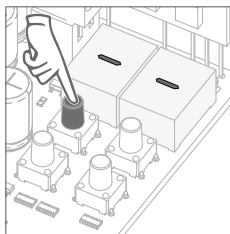

01 • Press MENU for 3 seconds.

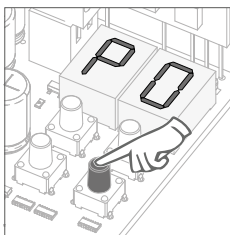

02 • P0 appears. Press ↓ seven times.

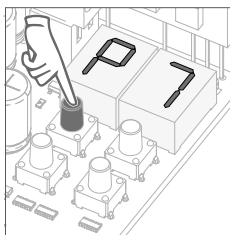

03 • P7 appears. Press MENU for 1 second.

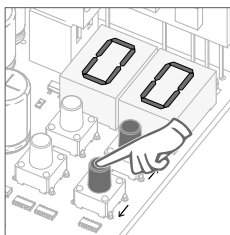

04 • Appears the function currently set. If you want, change the function to 00, 01 or 02, using ↓ ↑.

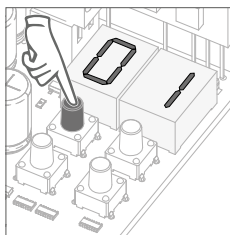

05 • Press MENU to save the defined function.

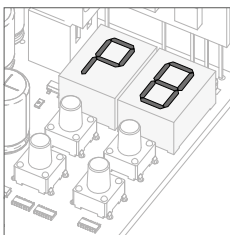

06 • P8 appears. To program P8, continue in step 3 from P8 menu (page 12B). To exit the programming press ↓ ↑ simultaneously.

| 00 | 01 | 02 |
|--|--|--|
| Intermittent (opening and closing) During the gate's opening/closing movement, the flashing light will work intermittently. | During movement of the gate (opening and closing), the flashing light will remain lit. | Courtesy light During operation it converts the firefly output into courtesy light according to the time defined in E2. (p.14B). |
| Factory default (00) | | |

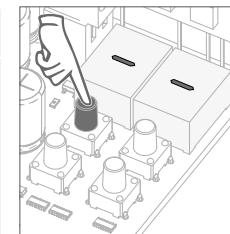

01 • Press MENU for 3 seconds.

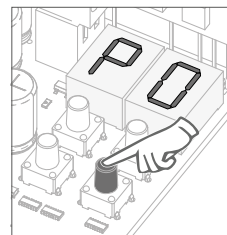

02 • P0 appears. Press ↓ eight times.

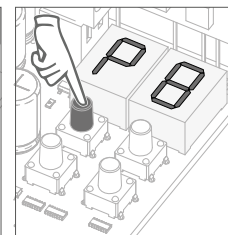

03 • P8 appears. Press MENU for 1 second.

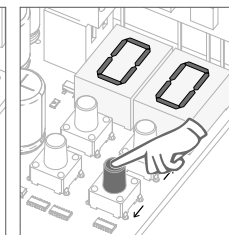

04 • Appears the function currently set. If you want, change the function to 00, 01 or 02, using ↓ ↑.

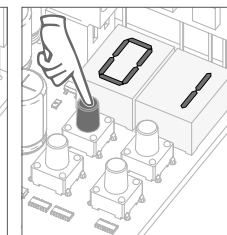

05 • Press MENU to save the defined function.

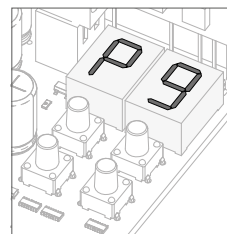

06 • P9 appears. To program P9, continue in step 3 from P9 menu (page 13A). To exit the programming press ↓ ↑ simultaneously.

04. PROGRAMMING "P"

P9 DISTANCE PROGRAMMING

00

distance PGM OFF

01

distance PGM ON

This menu allows you to enable or disable the new transmitters programming without access directly to the control board by using a previously stored transmitter (memorize transmitters page 5B).

Factory default (00)

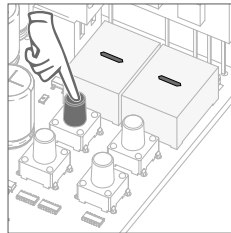

01 • Press MENU for 3 seconds.

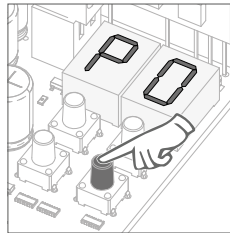

02 • P0 appears. Press ↓ nine times.

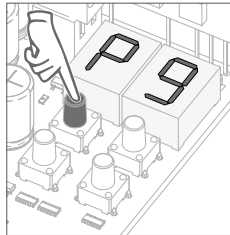

03 • P9 appears. Press MENU for 1 second.

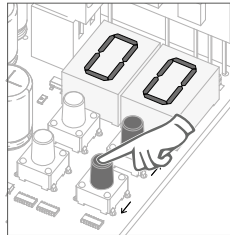

04 • Appears the function currently set. If you want, change the function to 00 or 01, using ↓ ↑.

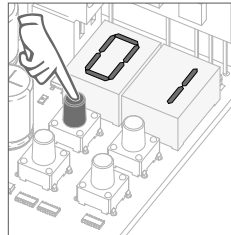

05 • Press MENU to save the defined function.

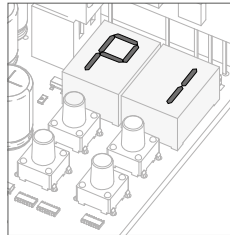

06 • P1 appears. To exit the programming press ↓ ↑ simultaneously.

Distance programming operation (PGM ON):



- Press the keys indicated in the picture at the same time for 10 seconds and the flashing light will start to flash (the display shows the 1st free position). Whenever you memorize a transmitter, the control board will leave the distance programming mode. If you want to program more transmitters, you will need to repeat the process of pressing simultaneously the transmitter buttons for 10 seconds for each new transmitter.

05. PROGRAMMING "E"

E0 PRESENT MAN

HP

Present man - closing
02 (activates present man at the closing)
The present man is active only in closing.

Present man
01 (activates present man)
The motor only works if you hold down the pushbutton LS or LO.

00 (deactivates present man)
Whenever an order is sent to the LS and LO the motor performs a complete maneuver.

(Factory default 00)

PL

Push button mode

| | LS Button | LO Button |
|-------------------|----------------------|-----------------|
| 01 ACTIVATED | Total Opening | Total Closing |
| 00 DEACTIVATED | Pedestrian maneuvers | Total maneuvers |

(Factory default 00)

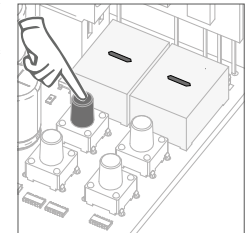

01 • Press MENU for 10 seconds.

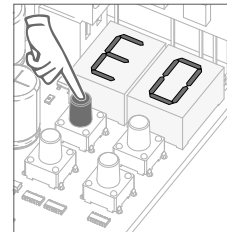

02 • E0 appears. Press MENU for 1 second.

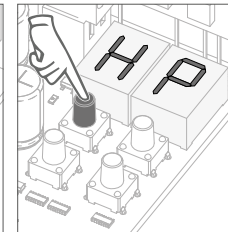

03 • HP appears. Press MENU for 1 second.

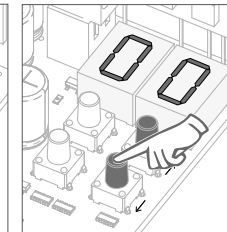

04 • Appears the function currently set. If you want, change the function to 00 or 01, using ↓ ↑.

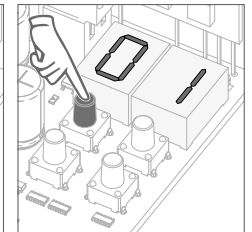

05 • Press MENU for 1 second to confirm the defined time.

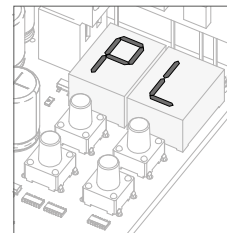

06 • PL appears. Press MENU for 1 second.

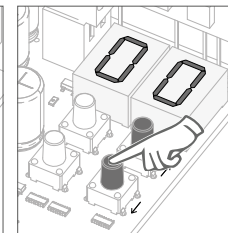

07 • Appears the function currently set. If you want, change the function to 00 or 01, using ↓ ↑.

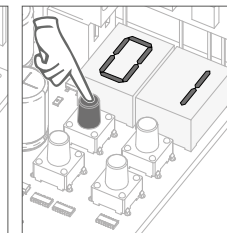

08 • Press MENU for 1 second to confirm the defined function.

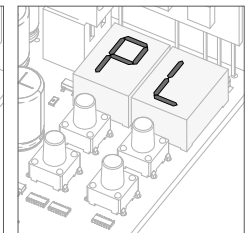

09 • E1 appears. To program E1, continue in step 3 from E1 menu (page 14A). To exit the programming press ↓ ↑ simultaneously.

**00 disabled function
01 enabled function**

This menu allows you to enable/disable soft start. With soft start function enabled, at each motion beginning, the control board will manage the start of the motor, gradually increasing in the first second of working.

(Factory default 00)

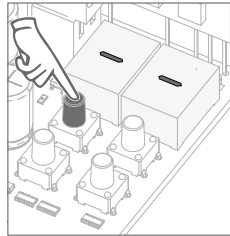

01 • Press MENU for 10 seconds.

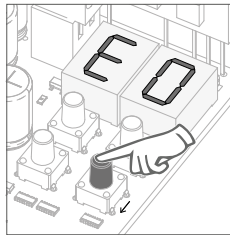

02 • E0 appears. Press ↓ once.

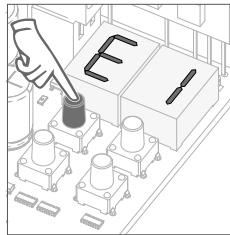

03 • E1 appears. Press MENU for 1 second.

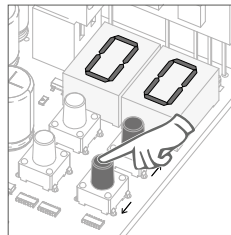

04 • Appears the function currently set. If you want, change the function to 00 or 01, using ↓ ↑.

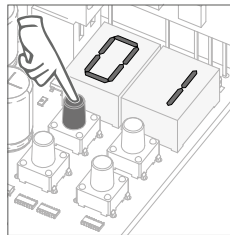

05 • Press MENU to save the defined function.

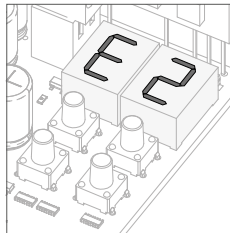

06 • E2 appears. To program E2, continue in step 3 from E2 menu (page 14B). To exit the programming press ↓ ↑ simultaneously.

This menu allows you to define the time (from 1 to 99 minutes) that the courtesy light stays on after the gate has completed an opening or closing operation. This menu is only available if the Courtesy Light function is active in the P8 menu (see page 12B)

(Factory default 01)

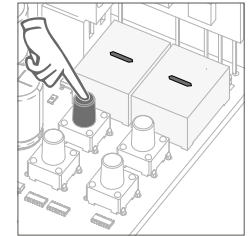

01 • Press MENU for 10 seconds.

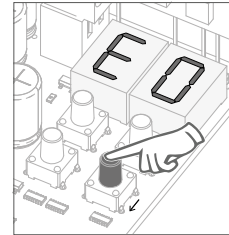

02 • E0 appears. Press ↓ twice.

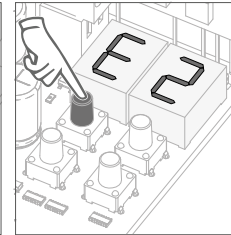

03 • E2 appears. Press MENU for 1 second.

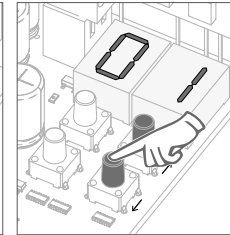

04 • Appears the time set from factory. If you want, change time between 1 and 99 sec., using ↓ ↑.

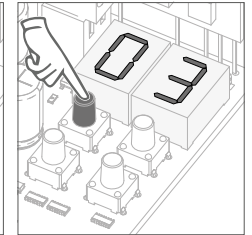

05 • Press MENU to save the defined time.

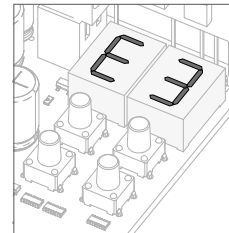

06 • E3 appears. To program E3, continue in step 3 from E3 menu (page 15A). To exit the programming press ↓ ↑ simultaneously.

00 disabled function
01 enabled function

This menu allows you to activate the option Follow me. With this function activated whenever the photocells detect the passage of a user/obstacle, the control board triggers the closing operation after 3 seconds.

To activate Follow me function, P5 have to be set with:
HE = 01 / HC = 00 (see page 12A)

(Factory default 01)

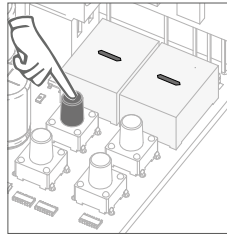

01 • Press MENU for 10 seconds.

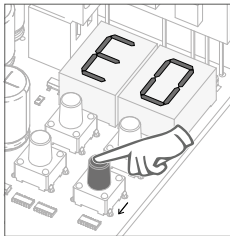

02 • E0 appears. Press ↓ three times.

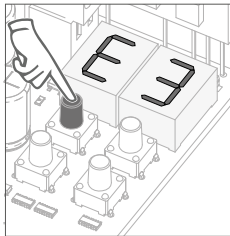

03 • E3 appears. Press MENU for 1 second.

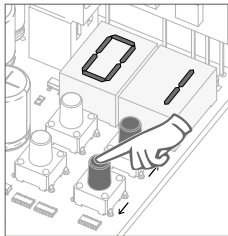

04 • Appears the function currently set. If you want, change the function to 00 or 01, using ↓ ↑.

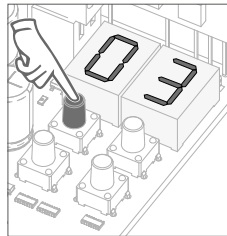

05 • Press MENU to save the defined function.

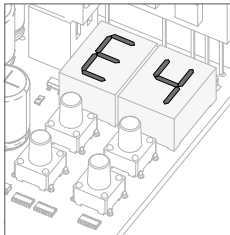

06 • E4 appears (is inactive). To advance to the E5 menu press ↓ once. To exit the programming press ↓ ↑ simultaneously.



E4 MENU INACTIVE.

00 disabled function
01 enabled function

The electric brake allows that, whenever the gate stops or it receives a reverse command, it decreases the advance.

(Factory default 00)

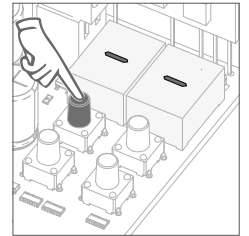

01 • Press MENU for 10 seconds.

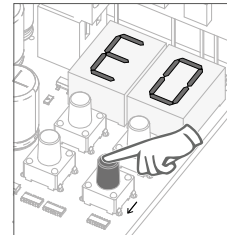

02 • E0 appears. Press ↓ five times.

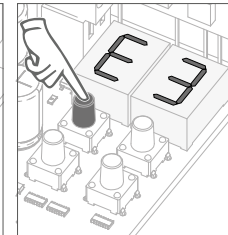

03 • E5 appears. Press MENU for 1 second.

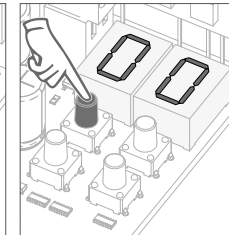

04 • Appears the function currently set. If you want, change the function to 00 or 01, using ↓ ↑.

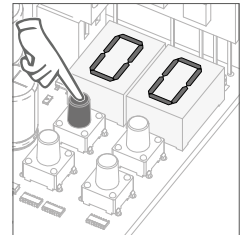

05 • Press MENU to save the defined function.

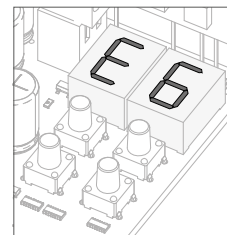

06 • E6 appears. To program E6, continue in step 3 from E6 menu (page 16A). To exit the programming press ↓ ↑ simultaneously.

This menu lets you set the deceleration speed in opening and closing. The higher the level, the faster is the deceleration.

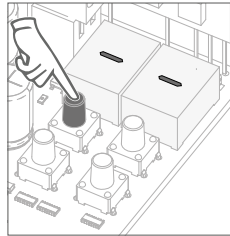

01 • Press MENU for 10 seconds.

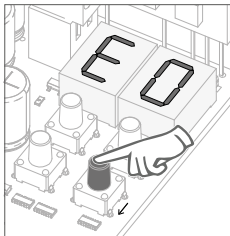

02 • E0 appears. Press ↓ six times.

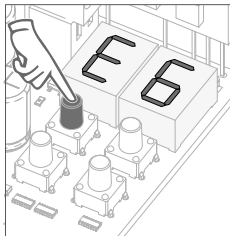

03 • E6 appears. Press MENU for 1 second.

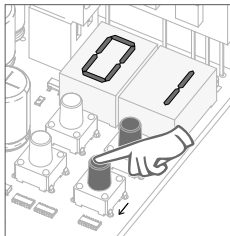

04 • Appears the value currently set. If you want, change the function to 01 or 09, using ↓ ↑.

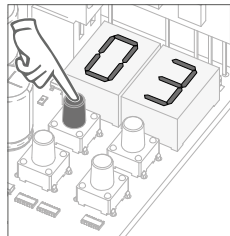

05 • Press MENU to save the defined value.

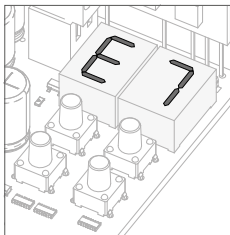

06 • E7 appears. To program E7, continue in step 3 from E7 menu (page 16B). To exit the programming press ↓ ↑ simultaneously.

This menu allows you to check how many complete maneuvers were performed by the control board (complete maneuver it is understood by opening and closing).
 ⚠ The control board reset does not erase the maneuvers count.

Example: 13456 maneuvers

01- Hundreds of thousands / 34- Thousands / 56- Dozens

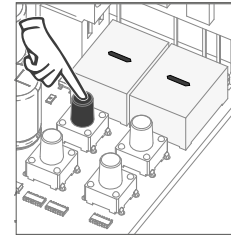

01 • Press MENU for 10 seconds.

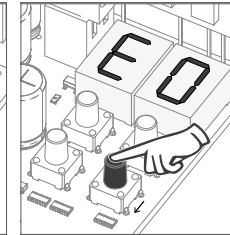

02 • E0 appears. Press ↓ six times.

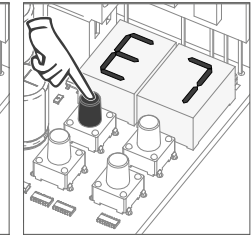

03 • Press MENU for 1 second.



display flashes →



display flashes →



04 • Appears the maneuvers counting in the following order (example 130 371):

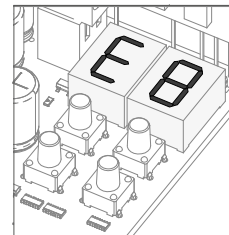

06 • E8 appears. To program E8, continue in step 3 from E8 menu (page 17A). To exit the programming press ↓ ↑ simultaneously.

By doing reset, all factory settings will be restored and all saved commands will be deleted. Only the maneuvers counter will have the data memorised.

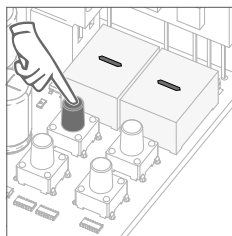

01 • Press MENU for 10 seconds.

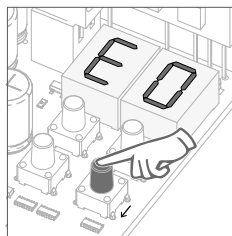

02 • E0 appears. Press ↓ eight times.

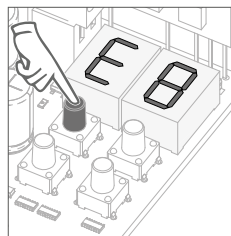

03 • E8 appears. Press MENU for 1 second.

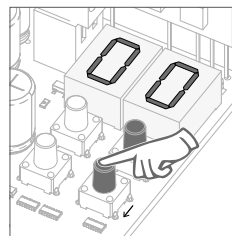

04 • Appears the function currently set. If you want to reset, change the function to 01, using ↓ ↑.

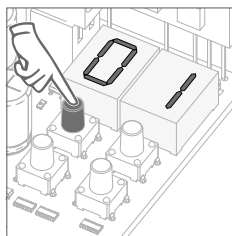

05 • Press MENU for 1 second to reset.

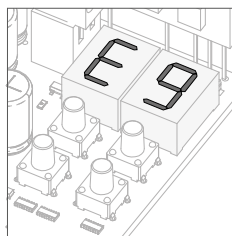

06 • E9 appears. To program E9, continue in step 3 from E9 menu (page 17B). To exit the programming press ↓ ↑ simultaneously.

00

Continuous light

01

Flashing light

(factory default 01)

This menu allows you to select the functioning mode of the four signs, fixed or intermittent output. page 13B)

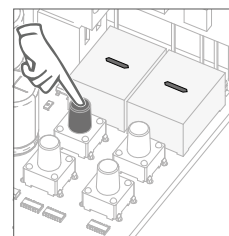

01 • Press MENU for 10 seconds.

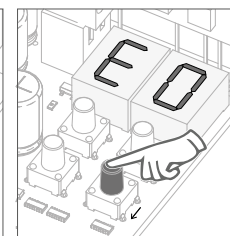

02 • E0 appears. Press ↓ nine times.

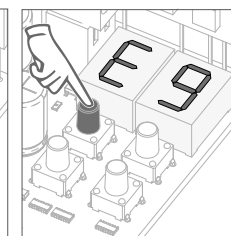

03 • E9 appears. Press MENU for 1 second.

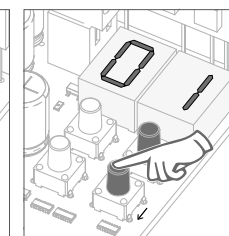

04 • Appears the function currently set. If you want, change the function to 00 or 01, using ↓ ↑.

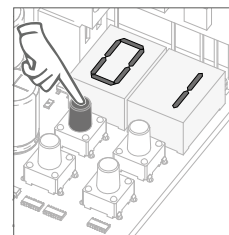

05 • Press MENU for 1 second to save the defined function.

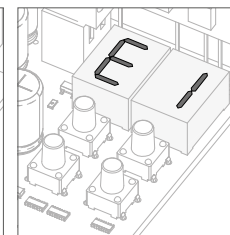

06 • E1 appears. To exit the programming press ↓ ↑ simultaneously.

06. DISPLAY

DISPLAY INDICATIONS

| MENU | DESCRIPTION | MENU | DESCRIPTION |
|------|------------------------------|------|---|
| OP | Opening limit-switch enabled | LE | Obstructed photocells |
| CU | Closing limit-switch enabled | LF | No limit switches or both open limit switches |
| AF | In pause time | EA | Security Band under pressure |
| AP | In pedestrian pause time | LS | Pedestrian button being pressed |
| UU | Memory full | EO | Start button being pressed |
| LP | Memory full (pedestrian) | EA | Sensibility detection failure |
| LI | Inversion by effort | | |

07. COMPONENTS TEST

INPUTS TEST

In the position corresponding to each transmitter input in low voltage, the control board has a LED to identify the condition of it. The LED on indicates that the input is closed, while the LED off indicates that the input is open.

07. COMPONENTS TEST

CAPACITOR SCHEME

To detect which components have problems during a sliding automatism installation, sometimes it's necessary to conduct tests with a direct connection to a 230V power supply. For this, it's necessary to interpose a capacitor on the connection so that the motor can work (check the capacitor type to be used in the product's manual). In the below diagram is shown how this connection must be made and how to merge the different component wires.

NOTES:

- To perform the tests you don't need to remove the automatism from its place, because this way you can understand if the automatism, directly connected to the power, can function correctly.
- The order of capacitor wires linked with the automatism wires are not important, as long as you link, one to the Brown wire and the other to the Black one;
- The common wire of the motor must always be connected to the power supply;
- To reverse the automatism functioning direction, switch the Black wire with the Brown wire of the automatism.

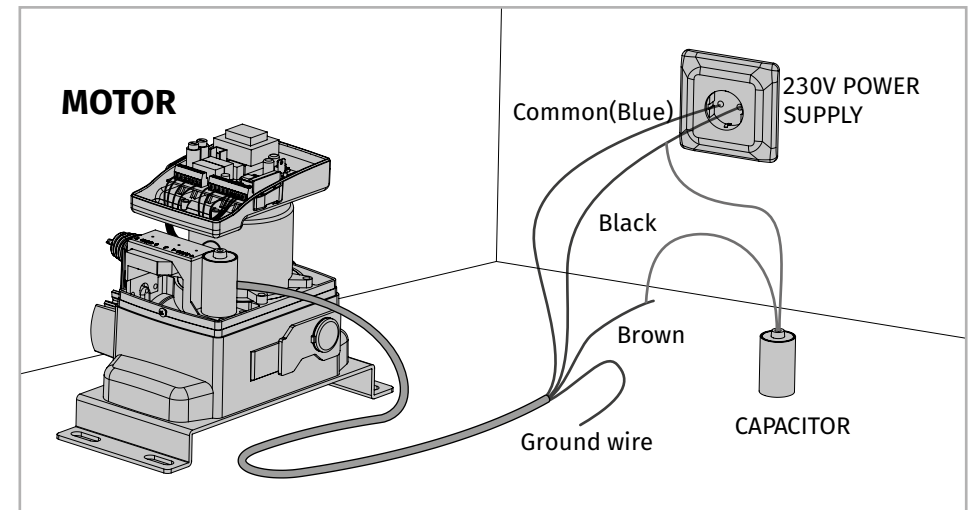

All tests must be performed by skilled technicians due to serious danger associated with the misuse of electrical systems!

| Anomaly | Procedure | Behavior | Procedure II | Discovering the origin of the problem | | | |
|--------------------------------------|---|---------------------------------------|---|--|---|---|--|
| • Motor doesn't work | • Make sure you have 230V power supply connected to control board and if it is working properly | • Still not working. | • Consult a qualified MOTORLINE technician. | 1 • Open control box and check if it has 230V power supply; 2 • Check input fuses; | 3 • Disconnect gate from control board and test them by connecting directly to power supply in order to find out if they have problems (see page 18B). | 4 • If the gate works, the problem is on the control board. Pull it out and send it to our MOTORLINE technical services for diagnosis; | 5 • If the gate doesn't work, remove them from installation site and send to our MOTORLINE technical services for diagnosis. |
| • Motor doesn't move but makes noise | • Unlock motor and move the gate by hand to check for mechanical problems on the movement | • Encountered problems? | • Consult a qualified gates technician. | 1 • Check motion axis and associated motion systems related with the motor and the gate to find out what is the problem. | | | |
| | | • The gate moves easily? | • Consult a qualified MOTORLINE technician. | 1 • Check capacitors, testing operator with new capacitor; | 2 • If capacitors are not the problem, disconnect motor from control board and it them by connecting directly to power supply in order to find out if it has problems (see page 18B). | 3 • If the motor works, the problem is from control board. Pull it out and send it to our MOTORLINE technical services for diagnosis; | 4 • If the motor doesn't work, remove them from installation site and send to our MOTORLINE technical services for diagnosis. |
| • Gate doesn't make complete route | • Unlock motor and move the gate by hand to closed position. Lock motor again and turn of power supply for 5 seconds. Reconnect it and send order to open gate using transmitter. | • Gate opened but didn't close again. | 1 • Check if there is any obstacle in front of the photocells; 2 • Check if any of the control devices (key selector, push button, video intercom, etc.) of the gate are jammed and sending permanent signal to control unit; 3 • Consult a qualified MOTORLINE technician. | All MOTORLINE control boards have LEDs that easily allow to conclude which devices are with anomalies. All safety devices LEDs (LA and LE) in normal situations remain On. All "START" circuits LEDs in normal situations remain Off. If LEDs devices are not all On, there is some security systems malfunction (photocells, safety edges), etc. If "START" circuits LEDs are turn On, there is a control device sending permanent signal. | A) SECURITY SYSTEMS: 1 • Close with a shunt all safety systems on the control board (check manual of the control board in question). If the automated system starts working normally check for the problematic device. 2 • Remove one shunt at a time until you find the malfunction device . 3 • Replace it for a functional device and check if the motor works correctly with all the other devices. If you find another one defective, follow the same steps until you find all the problems. | B) START SYSTEMS: 1 • Disconnect all wires from LS and LO terminal input (terminal 3 of CN3 connector). 2 • If the LED turned Off, try reconnecting one device at a time until you find the defective device. NOTE: In case procedures described in sections A) and B) don't result, remove control board and send to our technical services for diagnosis. | |
| • Motor opens but doesn't close | • Unlock motor and move gate by hand to check for mechanical problems on the gate. | • Encountered problems? | • Consult a qualified gates technician. | 1 • Check all motion axis and associated motion systems related with the gate to find out what is the problem. | | | |
| | | • The gate moves easily? | • Consult a qualified MOTORLINE technician. | 1 • Check capacitors, testing with new capacitors; 2 • If capacitors are not the problem, disconnect motor from control board and test it by connecting directly to power supply in order to find out if it is broken; 3 • If the motor doesn't work, remove it from installation site and send to our MOTORLINE technical services for diagnosis. | 4 • If motor work well and move gate at full force during the entire course, the problem is from controller. Set force using trimmer on the board. Make a new working time programming , giving sufficient time for opening and closing with appropriate force (page 08.B of this manual for MBM6 230V). 5 • If this doesn't work, remove control unit and send it to | MOTORLINE technical services services. | NOTE: Setting force of the controller should be sufficient to make the gate open and close without stopping, but should stop and invert with a little effort from a person. In case of safety systems failure, the gate shall never cause physical damaged to obstacles (vehicles, people, etc.). |

