

EN

## INSTALLATION AND USE INSTRUCTIONS

CHAIN ACTUATOR FOR  
WINDOW AUTOMATION

**MJ1**

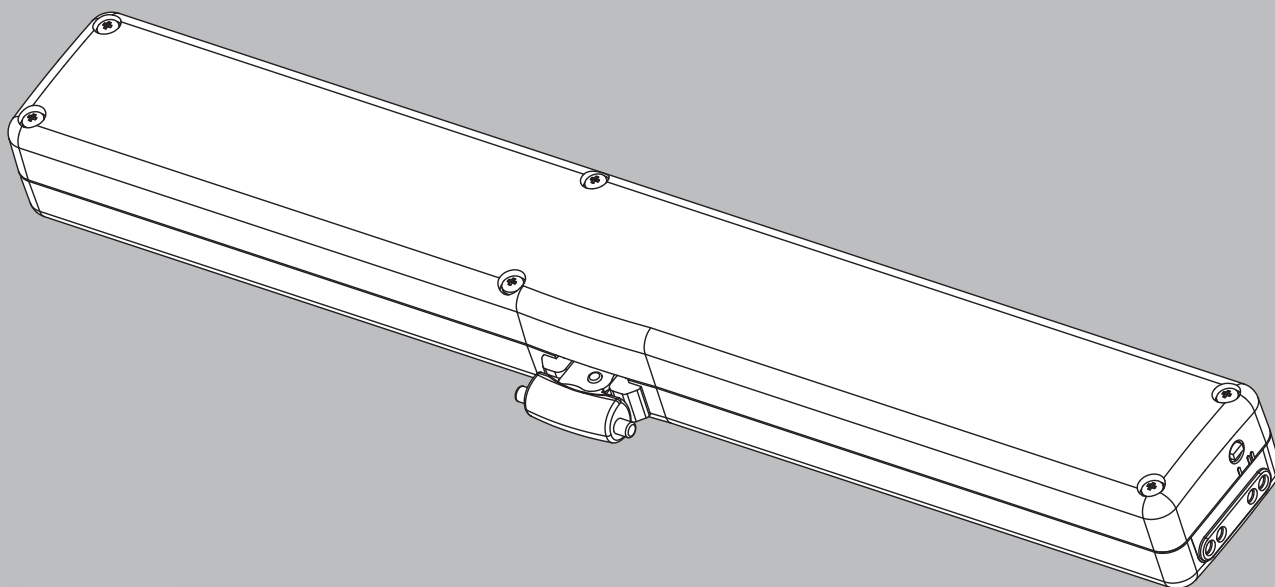

PATENTED



COD. 0P5186

VER.0.0

REV.06.10

**BEFORE INSTALLING AND USING THE ACTUATOR, IT IS  
COMPULSORY FOR THE INSTALLER AND THE USER TO READ  
AND UNDERSTAND THIS MANUAL IN ALL ITS PARTS.**

**THIS MANUAL IS INTEGRAL PART OF THE ACTUATOR  
AND MUST BE PRESERVED FOR FUTURE REFERENCE  
UNTIL DEMOLITION OF THE SAME.**



<b>1- DECLARATION OF “CE” CONFORMITY</b>	.....page 04
<b>2- GENERAL REMARKS</b>	
2.1- General instructions.....	page 05
2.2- Installer and user.....	page 05
2.3- Warranty.....	page 05
2.4- Technical assistance.....	page 05
2.5- Reserved rights.....	page 05
2.6- Description of personnel.....	page 06
<b>3- TECHNICAL DESCRIPTION</b>	
3.1- Rating plate and “CE” marking.....	page 07
3.2- Denomination of the components and dimensions.....	page 08
3.3- Technical data.....	page 10
3.4- Formulas for the calculation of thrust force or tractive force.....	page 11
3.5- Destination of use.....	page 11
3.6- Use Limits.....	page 12
3.7- Package.....	page 12
<b>4- SAFETY</b>	
4.1- General instructions.....	page 14
4.2- Safety Devices.....	page 14
4.2.1- Protections against electric hazard.....	page 14
4.3- Safety plates.....	page 15
4.4- Residual risks.....	page 15
<b>5- INSTALLATION</b>	
5.1- General instructions.....	page 16
5.2- Top hung windows.....	page 20
5.3- Bottom hung windows.....	page 21
5.4- Dome windows.....	page 22
5.5- Electrical Connections.....	page 24
5.6- Control devices.....	page 24
5.7- Correct assembly of the actuator on the window frame.....	page 25
5.8- Emergency procedures.....	page 26
<b>6- USE AND OPERATION</b>	
6.1- Use of the actuator.....	page 27
<b>7- MAINTENANCE</b>	
7.1- General instructions.....	page 28
<b>8- DEMOLITION</b>	
8.1- General instructions.....	page 28
<b>9- SPARE PARTS AND ACCESSORIES UPON REQUEST</b>	
9.1- General instructions.....	page 29
9.2- Brackets for vertical assembly.....	page 29
9.3- Quick coupling with integrated release push-button ARP ”.....	page 30
9.3.1- Dome windows.....	page 30
9.3.2- Emergency procedures.....	page 31
<b>FIGURES</b>	.....page 32
<b>CERTIFICATE OF GUARANTEE</b>	.....page 39



*declares that the electrical device*

*called: CHAIN ACTUATOR FOR WINDOW AUTOMATION*

*type: MJ1*

*models: MJ1/230V - MJ1/24V*

*Serial n° and year of manufacture: see data plate and CE marking applied to the device*

*complies with the requirements of the following directives:*

*2006/95/CE*

*Low Voltage Directive: electrical material for use within certain voltage limits.*

*2004/108/CE*

*Electromagnetic Compatibility Directive - Concerning the approximation of the laws of Member States relating to electromagnetic compatibility.*

*and also declares that the following harmonised standards have been applied:*

*EN55014-1*

*EN55014-2*

*EN61000-6-3*

*EN61000-6-2*

*EN50366*

*EN60335-1*

## 2.1- GENERAL INSTRUCTIONS



**BEFORE INSTALLING AND USING THE ACTUATOR, IT IS COMPULSORY THAT THE INSTALLER AND THE USER CAREFULLY READ AND UNDERSTAND THIS MANUAL IN ALL ITS PARTS.**



**THIS MANUAL IS INTEGRAL PART OF THE ACTUATOR AND MUST COMPULSORILY BE PRESERVED FOR FUTURE REFERENCE.**



**THE MANUFACTURER HAS NO LIABILITY FOR ANY EVENTUAL DAMAGE TO PERSONS, ANIMALS AND THINGS DUE TO THE INOBSERVANCE OF THE PRESCRIPTIONS DESCRIBED IN THIS MANUAL.**

## 2.2- INSTALLER AND USER



**THE ACTUATOR INSTALLATION CAN BE PERFORMED EXCLUSIVELY BY COMPETENT AND QUALIFIED TECHNICAL PERSONNEL SATISFYING THE PROFESSIONAL AND TECHNICAL REQUIREMENTS FORESEEN BY THE LAWS IN FORCE IN THE COUNTRY OF INSTALLATION.**



**THE ACTUATOR CAN BE USED EXCLUSIVELY BY A USER ACTING IN COMPLIANCE WITH THE INSTRUCTIONS CONTAINED IN THIS MANUAL AND/OR IN THE MANUAL OF THE ACTUATOR CONTROL DEVICE (E.G.: CONTROL UNIT).**

## 2.3- WARRANTY



**THE ACTUATOR WARRANTY EXPIRES, IF ITS USE DOES NOT COMPLY WITH THE INSTRUCTIONS AND PRESCRIPTIONS DESCRIBED IN THIS MANUAL, AS WELL AS IF NON-ORIGINAL COMPONENTS, ACCESSORIES, SPARE PARTS, AND CONTROL SYSTEMS ARE USED.**

## 2.4- TECHNICAL ASSISTANCE

For the technical assistance apply to your Dealer or to the Manufacturer.

## 2.5- RESERVED RIGHTS

The reserved rights on this manual "Installation and use instructions" remain property of the Manufacturer.

Each information herein contained (text, drawings, diagrams, etc.) is reserved.

None part of this manual can be reproduced and disclosed (totally or partially) by any reproduction means (photocopies, microfilms or other) without written authorization of the Manufacturer.

## 2.6- DESCRIPTION OF PERSONNEL



**USERS MUST NEVER PERFORM OPERATIONS RESERVED FOR MAINTENANCE PEOPLE OR SPECIALISED TECHNICIANS. THE MANUFACTURER DECLINES ALL LIABILITY FOR DAMAGE DERIVING FROM FAILURE TO OBSERVE THE ABOVE REQUIREMENTS.**

### **Specialised electrician:**

A specialised electrician must be able to install the actuator, start it and operate it both in normal conditions and in the maintenance mode; he/she is qualified to perform all electrical and mechanical adjustment and maintenance operations. He/she is allowed to work on live electrical cabinets and junction boxes.

### **User:**

specialised person capable of operating the actuator under normal conditions by using the relative controls. He/she must also be able to operate with the actuator under “maintenance” in order to perform simple routine maintenance operations (cleaning), and start or reset the actuator following an unscheduled stop.

### 3.1- RATING PLATE AND “CE” MARKING

The “CE” marking certifies the compliance of the machine with the essential safety and health requirements foreseen by the product European Directives.

The rating plate is an adhesive plate in polyester, silk-screen printed in black, having the following size: L=36 mm - H=50 mm.

It is applied externally on the actuator. The plate (**Fig. 1**) bears in readable and indelible way the following data:

- logo and address of the manufacturer
- type and model
- voltage and intensity of power supply (V - A)
- absorbed electric power P (W)
- thrust and tractive force F (N)
- type of service  $\zeta$  (min)
- idle translation speed (mm/s)
- protection degree (IP)
- “CE” marking
- symbol of WEEE Directive 2002/96/CE
- symbol of double insulation (only for mod. MJ1/230V)
- serial number

**Fig. 1**



3.2- DENOMINATION OF THE COMPONENTS AND DIMENSIONS

Fig. 2a Dimensions in mm

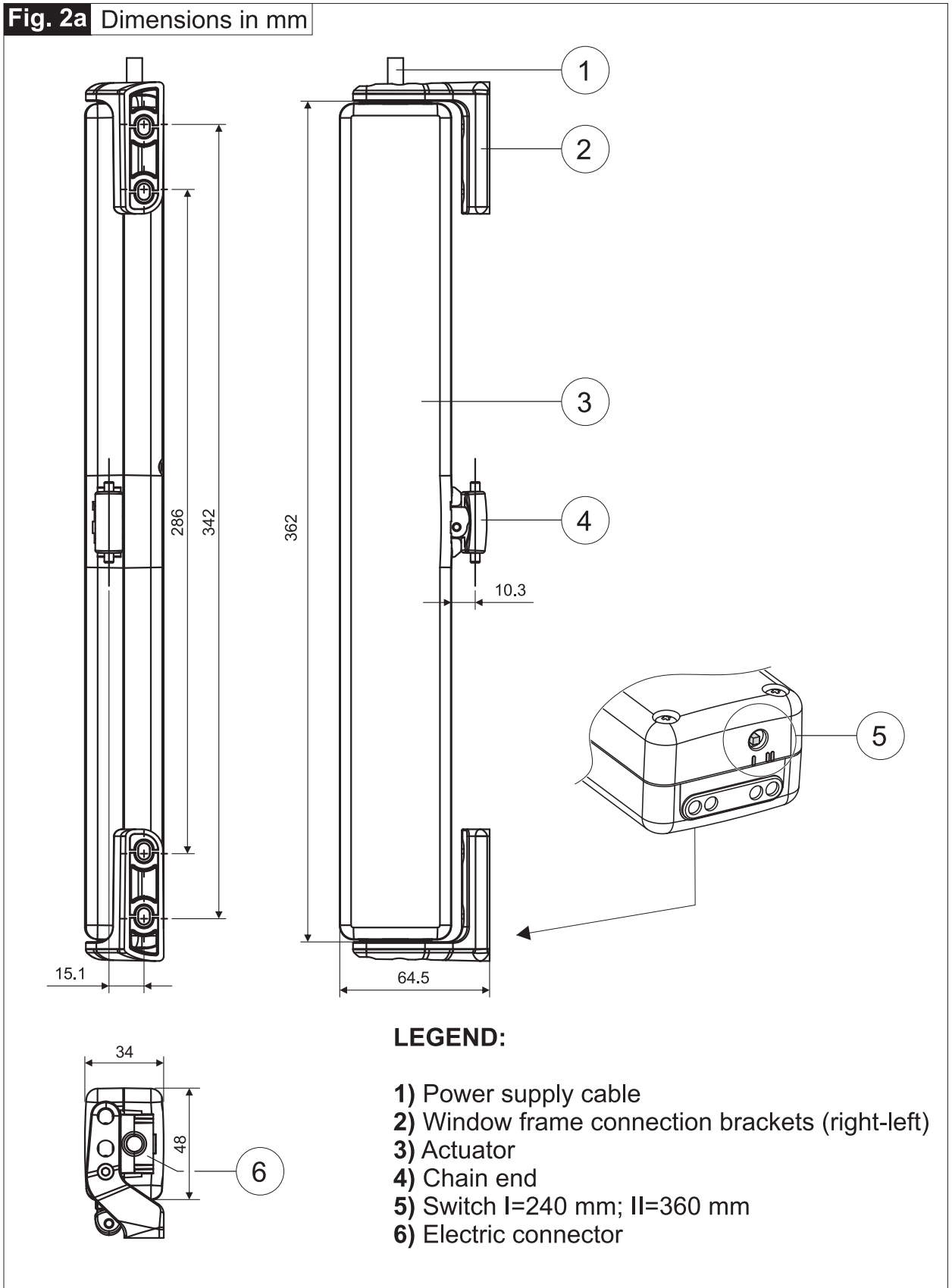



**Fig. 2b** Dimensions in mm

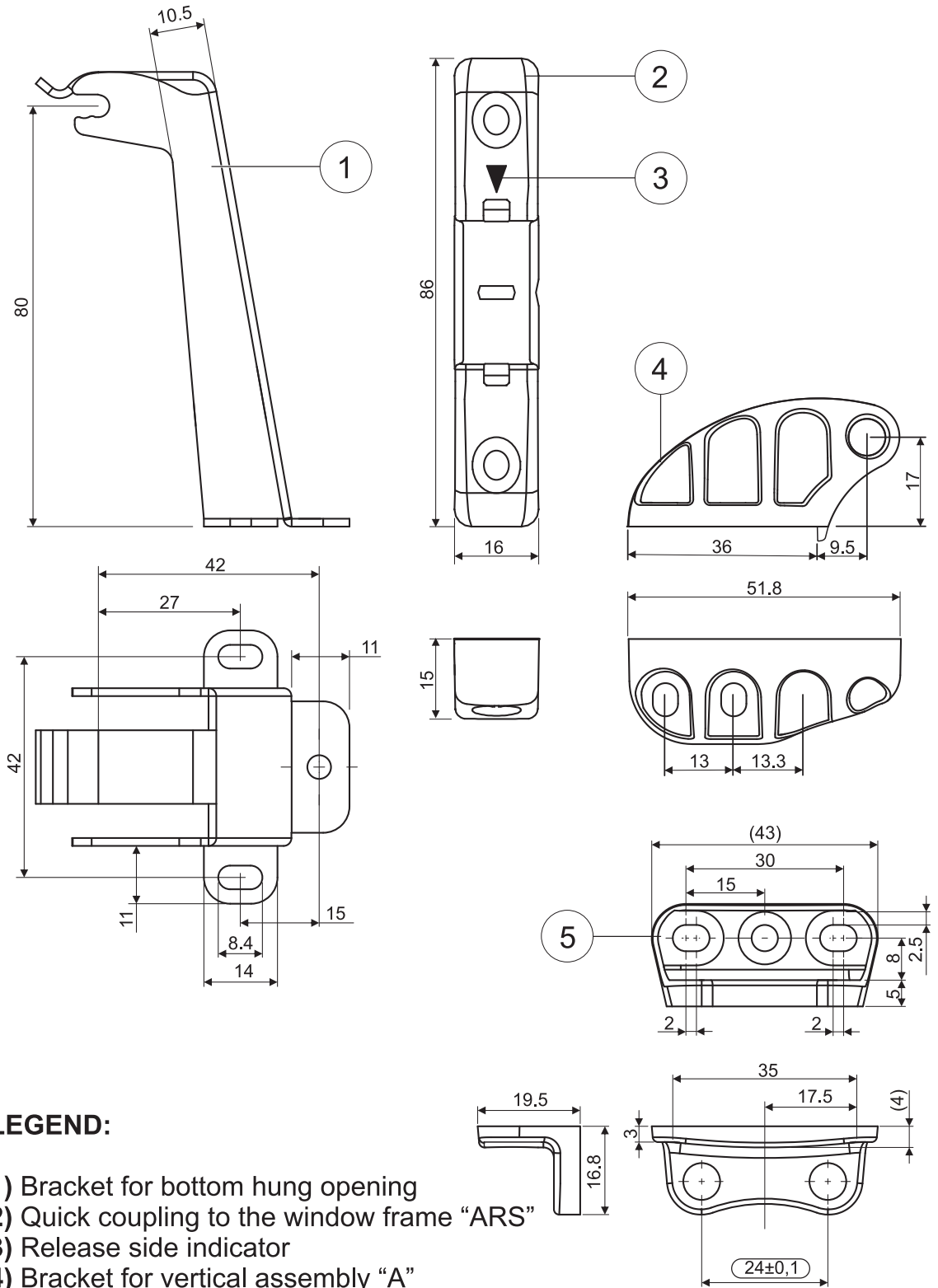

**LEGEND:**

- 1) Bracket for bottom hung opening
- 2) Quick coupling to the window frame "ARS"
- 3) Release side indicator
- 4) Bracket for vertical assembly "A"
- 5) Bracket for vertical assembly "B"

## 3.3- TECHNICAL DATA

Tab. 1 contains the technical data characterising the actuators.

	MJ1/230V	MJ1/24V	
Power supply voltage	230 V - 50 Hz	24 V 	
Absorbed current	0,12 A	0,43 A	
Absorbed power with load	25 W	9 W	
Thrust force	300 N		
Tractive force	200 N		
Idle translation speed	8 mm/s	7,5 mm/s	
Duration of the idle stroke (360 mm)	46 s	48 s	
Operation stroke length (mm) <sup>(1)</sup>		240	360
Minimum window frame height (mm) <sup>(2)</sup>	Top hung	250	360
	Bottom hung	500	900
	Dome	300	400
Limit switch: Electronic for opening - by amperometric absorption for closing.			
Protection against electric shock	Classe II	Classe III	
Type of service S <sub>2</sub> <sup>(3)</sup>	4 min		
Operating temperature	- 5 °C + 50 °C		
Protection degree of electric devices	IP 30		
Adjustment of the window frame connection	NO		
Parallel electric connection of more actuators on the same window	NO		
Parallel electric connection of more actuators on different windows	Yes (see wiring diagram)		
Actuator weight with brackets	0,97 kg		
Gross weight	1,15 kg		
<sup>(1)</sup> Tolerance on the precision of limit switch tripping at output: +/- 2 cm. <sup>(2)</sup> Actuator distance from the window frame opening hinge <sup>(3)</sup> Service of limited duration according to EN 60034			

Tab. 1

### 3.4- FORMULAS FOR THE CALCULATION OF THRUST AND TRACTIVE FORCE

**Fig. 3**

#### Horizontal domes or skylights

**F**= Force necessary for opening or closing

**P**= Weight of the skylight or dome  
(Only movable part)

$$F = 0.54 \times P$$

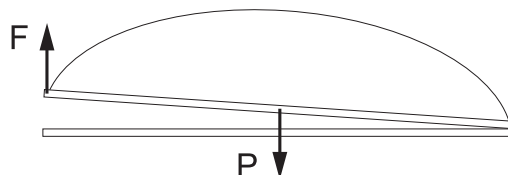
**Fig. 4**

#### Top hung windows (A) or bottom hung windows (B)

**F** = Force necessary for opening or closing

**P** = Weight of the window  
(Only movable part)

**C** = Window opening stroke

**H** = Window height (Only movable part)

$$F = (0.54 \times P) \times \left( \frac{C}{H} \right)$$

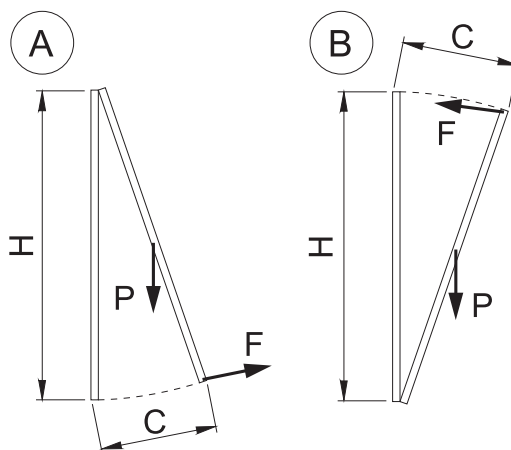

### 3.5- DESTINATION OF USE



THE ACTUATOR HAS BEEN DESIGNED AND MANUFACTURED TO PERFORM AUTOMATICALLY, BY MEANS OF A COMMAND DEVICE, THE OPENING AND CLOSING OF TOP HUNG WINDOWS, BOTTOM HUNG WINDOWS, PIVOT WINDOWS, AND SKYLIGHTS.

### 3.6- USE LIMITS

The actuator has been designed and manufactured exclusively for the destination of use given in **par. 3.5**, therefore, any other type of use is strictly forbidden in order to assure in any moment the safety of the installer and of the user, as well as the efficiency of the actuator itself.



**IT IS STRICTLY FORBIDDEN TO USE THE ACTUATOR FOR IMPROPER USES, I.E. OTHER THAN THE ONE FORESEEN BY THE MANUFACTURER (SEE PAR. 3.5).**



**IT IS STRICTLY FORBIDDEN TO INSTALL THE ACTUATOR ON THE EXTERNAL SIDE OF THE WINDOW FRAME SUBJECT TO ATMOSPHERIC AGENTS (RAIN, SNOW, ETC.).**



**THE USE OF THE ACTUATOR IN ENVIRONMENTS WITH POTENTIALLY EXPLOSIVE ATMOSPHERE IS STRICTLY FORBIDDEN.**



**IT IS COMPULSORY TO KEEP THE PACKAGE AND THE ACTUATOR OUT OF REACH OF CHILDREN.**

### 3.7- PACKAGE

Each package of the product (cardboard box) contains **(Fig. 5)**:

- No. 1 Actuator equipped with power supply cable (with electric connector);
- No. 2 Window frame connection brackets (right-left) **(Ref. A)**;
- No. 1 Bracket for bottom hung opening **(Ref. B)**;
- No. 1 Adhesive drilling template **(Ref. C)**;
- No. 1 Small parts package for aluminum windows (No. 2 screws for lateral fastening of connection brackets to the window, No. 7 screws AF Ø 4,8 x 16 mm and No. 2 screws AF Ø 4,2 x 19 mm for the fastening of the brackets to the window frame and for ARS coupling fastening) **(Ref. D)**;
- No. 1 ARS coupling release tool **(Ref. D-1)**;
- No. 1 ARS coupling **(Ref. D-2)**;
- No. 1 Installation and use instructions **(Ref. E)**;
- No. 1 Safety plate **(Fig. 6)**;



**MAKE SURE THAT THE ABOVE DESCRIBED COMPONENTS ARE CONTAINED IN THE PACKAGE, AS WELL AS THAT THE ACTUATOR HAS NOT BEEN DAMAGED DURING TRANSPORT.**



**SHOULD ANY ANOMALY BE DETECTED, IT IS FORBIDDEN TO INSTALL THE ACTUATOR, AND IT IS COMPULSORY TO REQUIRE TECHNICAL ASSISTANCE FROM YOUR DEALER OR THE MANUFACTURER.**



**THE PACKAGING (PAPER, PLASTIC, ETC.) HAS TO BE DISPOSED ACCORDING TO THE LAWS IN FORCE.**

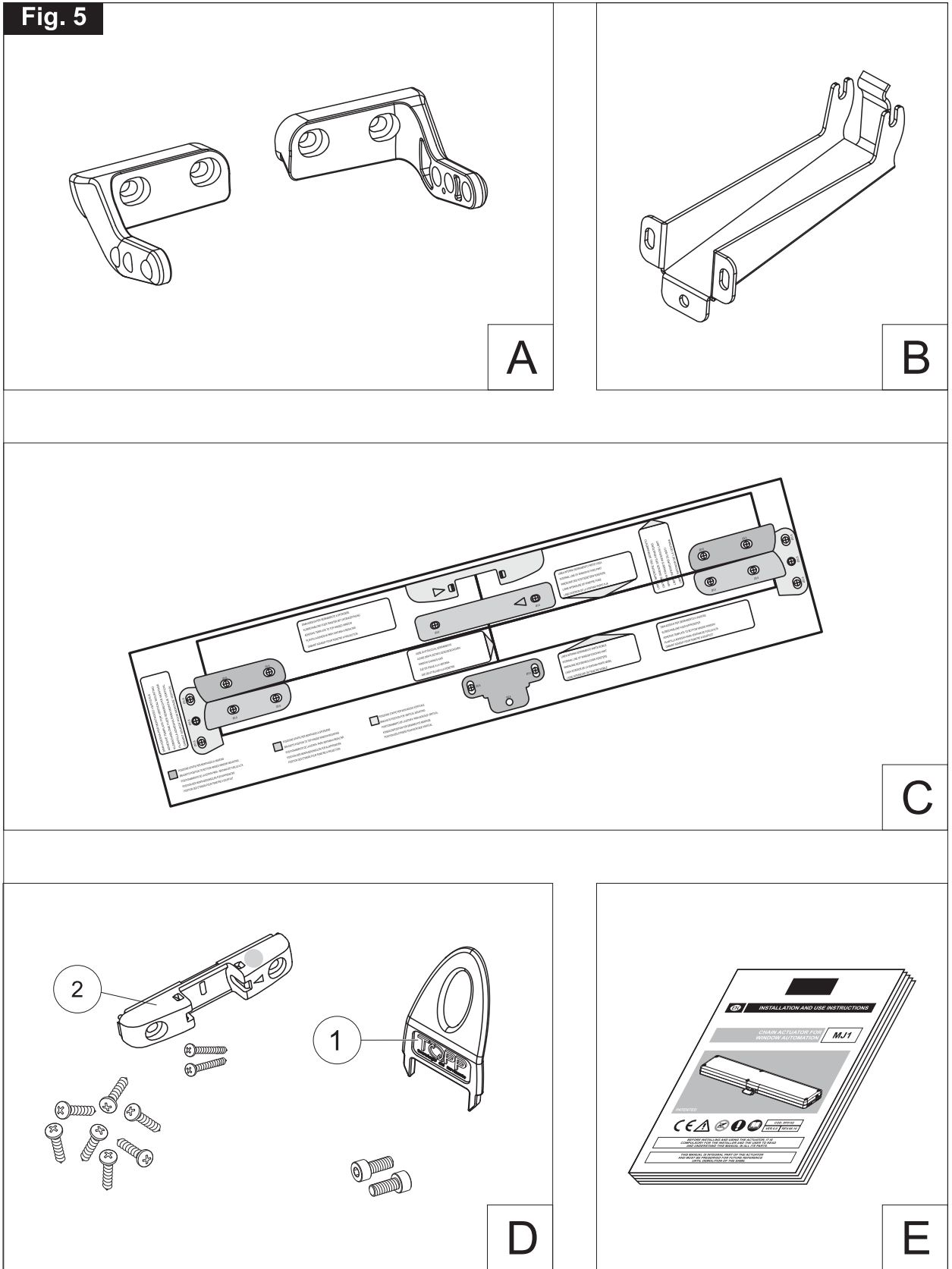

## 4.1- GENERAL INSTRUCTIONS



**OPERATORS MUST BE INFORMED OF ACCIDENT RISKS, SAFETY DEVICES AND THE GENERAL ACCIDENT PREVENTION REGULATIONS ESTABLISHED BY INTERNATIONAL DIRECTIVES AND BY THE LAW IN FORCE IN THE COUNTRY OF USE. ALL OPERATORS MUST STRICTLY COMPLY WITH THE ACCIDENT PREVENTION REGULATIONS IN FORCE IN THE COUNTRY OF USE.**



**DO NOT REMOVE OR ALTER THE PLATES PLACED ON THE ACTUATOR BY THE MANUFACTURER.**



**IF THE WINDOW FRAME IS ACCESSIBLE FROM OR INSTALLED AT A HEIGHT OF LESS THAN 2.5 m FROM THE GROUND, AND IF IT CAN BE COMMANDED BY AN UNTRAINED USER OR WITH A REMOTE CONTROL DEVICE, FIT AN EMERGENCY STOP SYSTEM WHICH AUTOMATICALLY CUTS IN TO PREVENT THE RISK OF CRUSHING OR DRAGGING PARTS OF THE BODY INSERTED BETWEEN THE MOVING AND FIXED PARTS OF THE WINDOW FRAME.**



**ANY TAMPERING WITH OR UNAUTHORISED REPLACEMENT OF ONE OR MORE PARTS OR COMPONENTS OF THE ACTUATOR, OR THE USE OF UNORIGINAL ACCESSORIES AND CONSUMABLES, MAY INCREASE THE RISK OF ACCIDENT AND THUS RELIEVES THE MANUFACTURER OF ALL CIVIL AND PENAL LIABILITY.**



**EXTRAORDINARY AND ROUTINE MAINTENANCE OPERATIONS INVOLVING THE TOTAL OR PARTIAL DISMOUNTING OF THE ACTUATOR MAY ONLY BE PERFORMED AFTER DISCONNECTING IT FROM THE POWER SUPPLY.**



**THIS APPLIANCE MAY NOT BE USED BY PERSONS (CHILDREN INCLUDED) WITH REDUCED PHYSICAL, SENSORIAL OR MENTAL CAPACITIES, OR INEXPERT PEOPLE, UNLESS THEY ARE SUPERVISED AND TAUGHT HOW TO USE IT BY A PERSON RESPONSIBLE FOR THEIR SAFETY. CHILDREN MUST BE CONTROLLED TO MAKE SURE THEY DO NOT PLAY WITH THE APPLIANCE.**

## 4.2- SAFETY DEVICES

### 4.2.1- PROTECTION AGAINST ELECTRIC HAZARD

The actuator is protected against electric hazard due to direct and indirect contacts. The protection measures against direct contacts aim at protecting people against hazards due to contact with active parts, usually live parts; while the protection measures against indirect contacts aim at protecting people against hazards due to conducting part, which are usually insulated, but could become live in case of failure (insulation failure).

The adopted protection measures are the following:

- 1) Insulation of live parts by means of a plastic material body;
- 2) Enclosure with suitable protection degree;

**3) Only for Mod. MJ1/230 V equipped with double insulation:** Protection of passive type given by the use of components with double insulation, also called components of class II or with equivalent insulation. (It is forbidden to connect the actuators equipped with double insulation to the earth plant.)

#### 4.3- SAFETY PLATES



**IT IS FORBIDDEN TO REMOVE, MOVE, SPOIL OR IN ANYWAY REDUCE THE VISIBILITY OF THE SAFETY PLATES. FAILURE TO OBSERVE THE ABOVE MAY CAUSE SERIOUS HARM TO PEOPLE AND DAMAGE TO PROPERTY. THE MANUFACTURER DECLINES ALL LIABILITY FOR ANY DAMAGE CAUSED BY THE FAILURE TO OBSERVE THE ABOVE REQUIREMENT.**

**Fig. 6** illustrates the safety plate: this must be applied directly to the outside of the actuator or near it and always in a position where it can be seen by the installer and/or operator.

#### 4.4- RESIDUAL RISKS

The installer and the user are herewith informed that after the actuator has been installed on the window, the actuator drive can accidentally generate the following residual risk:

**Residual risk:** Hazard of squashing or dragging of body parts inserted between the movable and the fix part of the window frame.

**Exposure frequency:** Accidental and when the installer or the user decides to perform a wrong voluntary action.

**Severity of the damage:** Light lesions (usually reversible).

**Adopted measures:** Before enabling the device, it is compulsory to verify that near the window there are not persons, animals or things whose safety may be accidentally jeopardized. During actuator operation, it is compulsory to be in a safe control position assuring visual control on the window movement (**see par.6.1**).

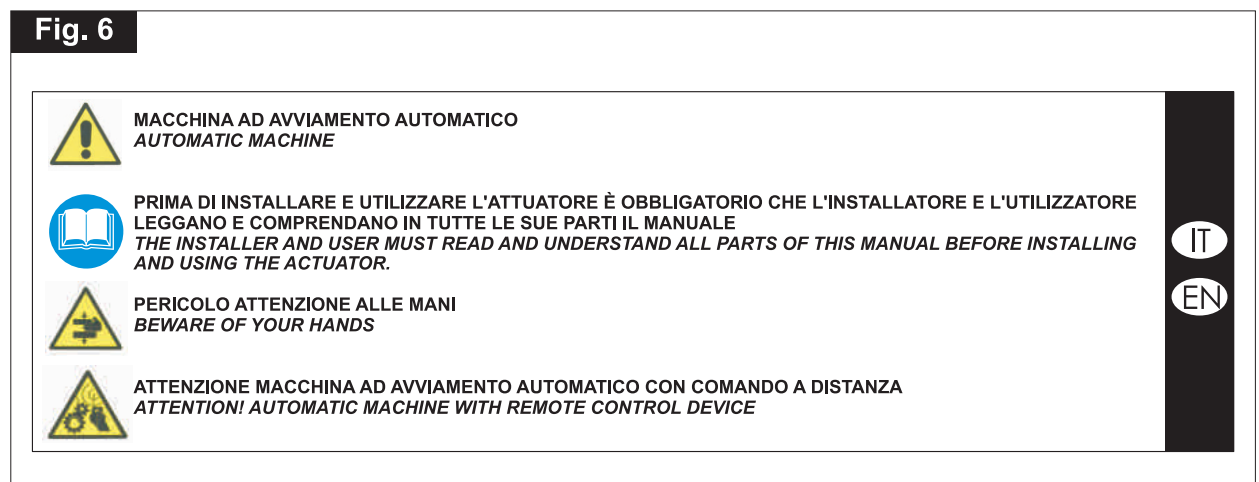

## 5.1- GENERAL INSTRUCTIONS



THE ACTUATOR INSTALLATION CAN BE PERFORMED EXCLUSIVELY BY COMPETENT AND QUALIFIED TECHNICAL PERSONNEL SATISFYING THE PROFESSIONAL AND TECHNICAL REQUIREMENTS FORESEEN BY THE LAWS IN FORCE IN THE COUNTRY OF INSTALLATION.



THE ACTUATOR PERFORMANCE MUST BE SUFFICIENT TO ASSURE THE CORRECT MOVEMENT OF THE WINDOW. IT IS COMPULSORY TO VERIFY THE THRUST OR TRACTIVE FORCE ACCORDING TO THE TYPE AND WEIGHT OF THE WINDOW (PAR. 3.4). IT IS FORBIDDEN TO EXCEED THE LIMITS SET IN TAB. 1 CONCERNING TECHNICAL DATA (PAR. 3.3).



THE ACTUATOR INSTALLATION MUST BE PERFORMED EXCLUSIVELY WITH CLOSED WINDOW OR SKYLIGHT.



BEFORE PERFORMING THE INSTALLATION OF THE ACTUATOR ON BOTTOM HUNG WINDOWS, VERIFY THAT ON BOTH SIDES OF THE WINDOW TWO COMPASS STROKE LIMIT DEVICES ARE INSTALLED IN ORDER TO AVOID THE ACCIDENTAL FALL OF THE WINDOW.



FOR CORRECT OPERATION OF THE ACTUATOR, THE WINDOW FRAME MUST HAVE A MINIMUM HEIGHT VALUE INCLUDED IN THE RANGE STATED IN TABLE FIG. 7a FOR TOP HUNG ASSEMBLY, IN TABLE FIG. 7b FOR BOTTOM HUNG ASSEMBLY, AND IN TABLE FIG. 7c FOR THE DOME ASSEMBLY.



THE STROKE SELECTION HAS TO BE CARRIED OUT WITH SWITCHED OFF ACTUATOR ONLY BY COMPETENT AND QUALIFIED TECHNICAL PERSONNEL.



VERIFY THAT THE POSITIONS OF THE LABELS LOCATED ON THE QUICK COUPLING CORRESPOND TO THE LABELS ON THE ACTUATOR: RED LABEL WITH LETTER "A" FOR THE TOP HUNG ASSEMBLY, GREEN LABEL WITH LETTER "B" FOR VERTICAL ASSEMBLY.



VERIFY THAT DISTANCE "D" BETWEEN THE ACTUATOR SHELL AND THE CHAIN END (FIG. 7a/7b/7c) IS GREATER THAN 5 mm.



IF THE WING AND THE FRAME ARE COPLANAR PROCEED WITH THE ASSEMBLY ACCORDING TO FIG. 7.



THE FITTING SURFACE FOR THE ARS RAPID COUPLING DEVICE MUST BE PERFECTLY FLAT AND/OR SMOOTH.



Fig. 7a Dimensions in mm

TOP HUNG OPENING		
POS.	ROTATION AXIS	POS. FROM THE WINDOW FRAME
<b>B</b>	<b>1</b>	STANDARD POS.
<b>B</b>	<b>2</b>	-10 mm
<b>A</b>	<b>1</b>	-5 mm

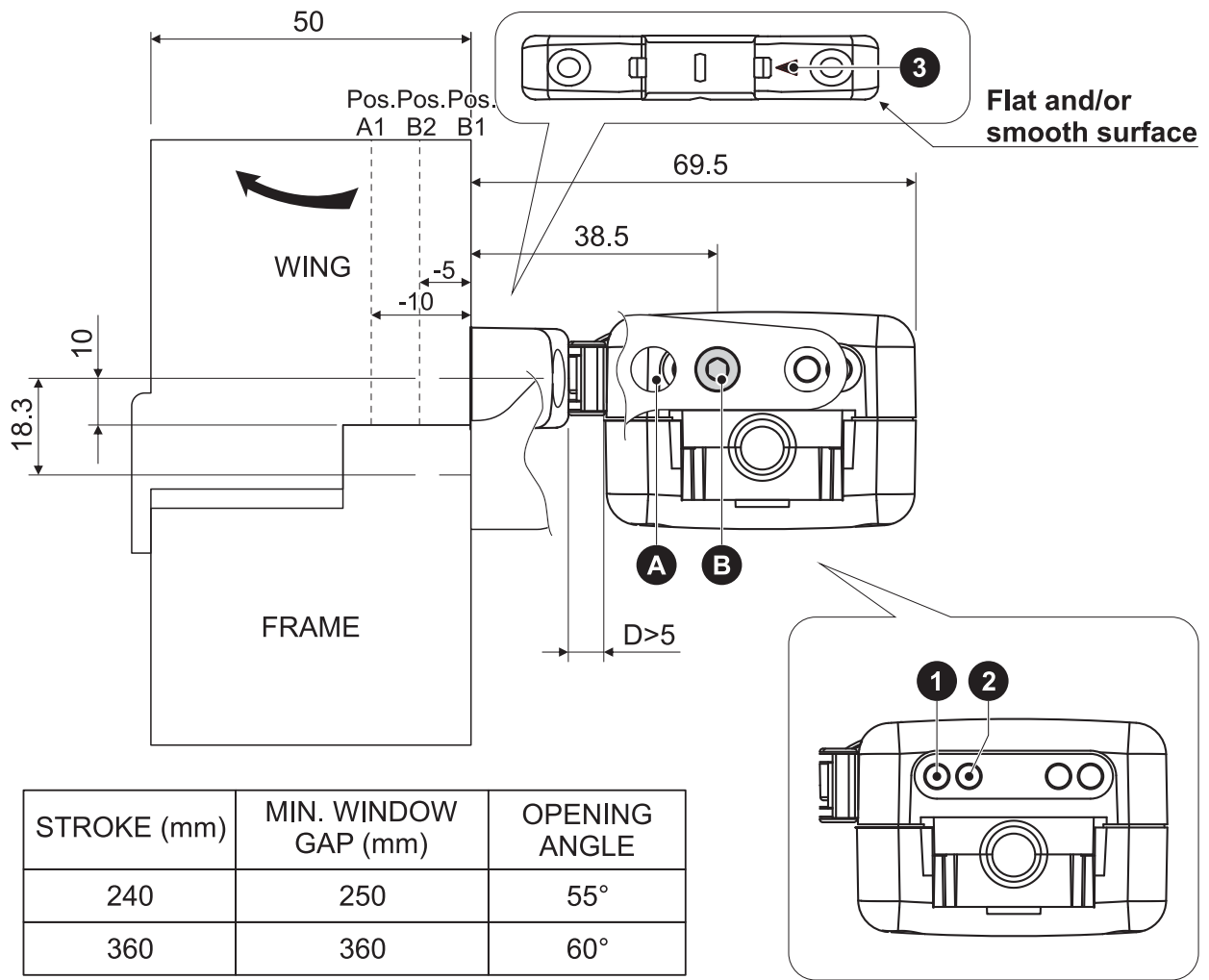

THE RELEASE SIDE INDICATOR (REF. 3) IN THIS ASSEMBLY TYPE HAS TO BE ON THE RIGHT.



USE ONLY A SCREW IN POSITION "A" OR "B".



IF THE WINDOW FRAME IS COPLANAR, REMOVE THE ACTUATOR FROM THE WINDOW FRAME USING THE APPLICATIONS OF THE ABOVE GIVEN TABLE.

Fig. 7b Dimensions in mm

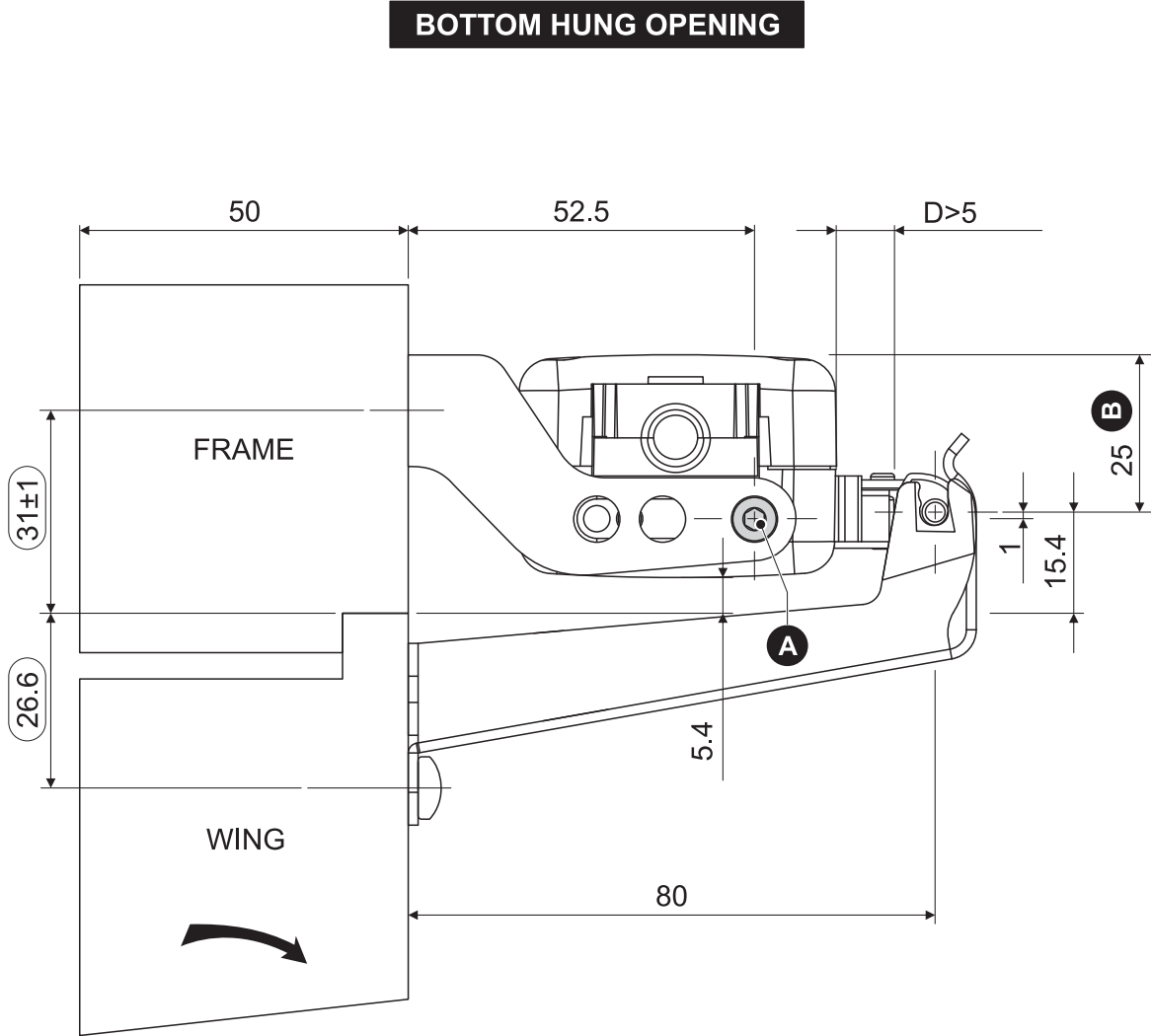

STROKE (mm)	MIN. WINDOW GAP (mm)	OPENING ANGLE	"B" MOTOR OVERALL DIMENSIONS (mm)
240	500	26°	33.6
360	900	22°	31.6



**USE ONLY A SCREW IN POSITION "A".**

**Fig. 7c** Dimensions in mm

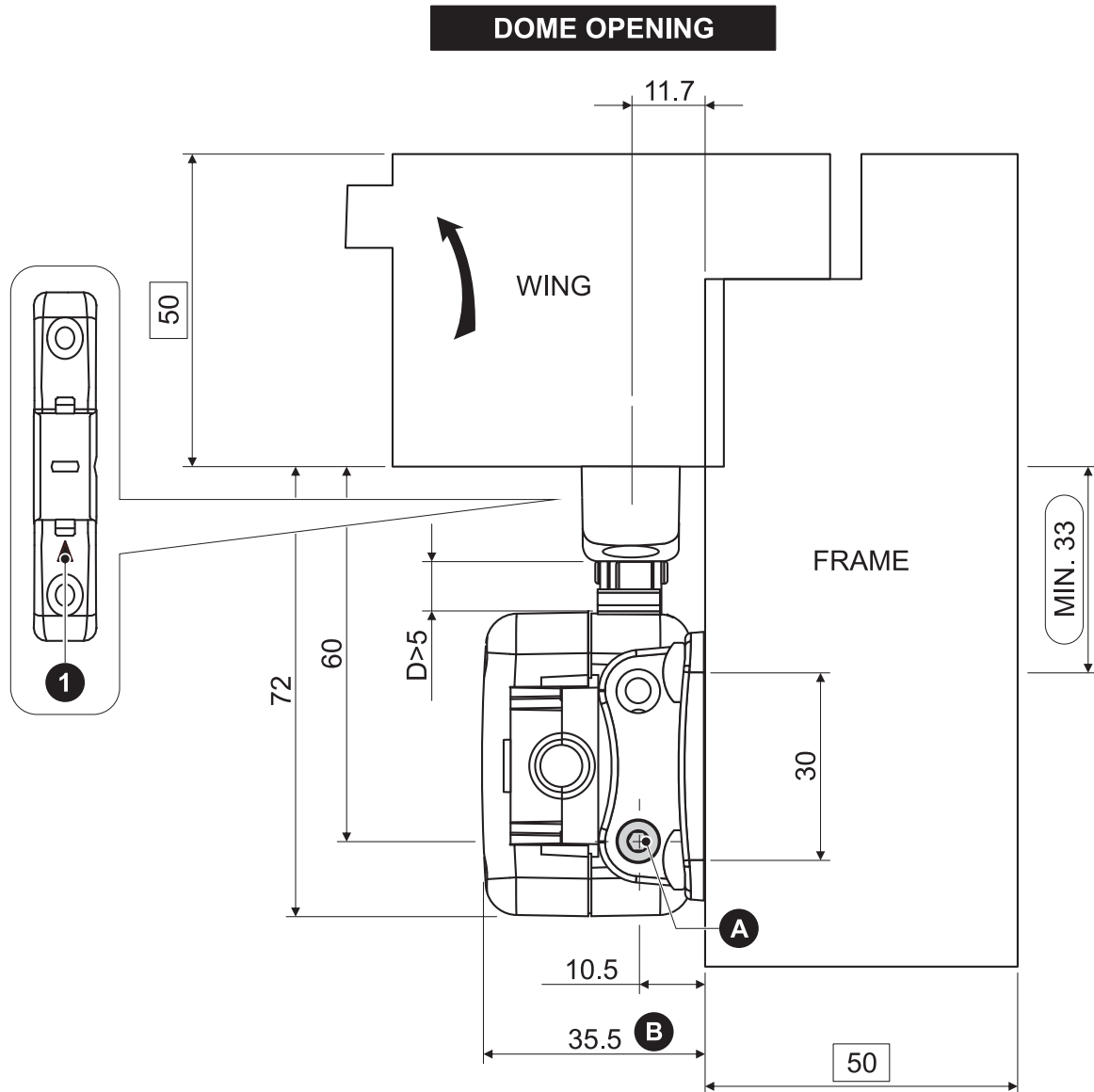

STROKE (mm)	MIN. WINDOW GAP (mm)	OPENING ANGLE	"B" MOTOR OVERALL DIMENSIONS (mm)
240	300	48°	40
360	400	55°	43



**THE RELEASE SIDE INDICATOR (REF. 1) IN THIS ASSEMBLY TYPE HAS TO BE ON THE LEFT.**



**USE ONLY A SCREW IN POSITION "A".**

## 5.2- TOP HUNG WINDOWS (Fig. 8 and Fig. 19 ÷ 27)

- 1) Open the package (**par. 3.7**) and extract the various components;
- 2) **Fig. 19-** With a pencil draw the centre line "X" of the window frame;
- 3) **Fig. 20-** Apply the adhesive template (**Ref. 1**) on the window frame aligning it with the previously drawn centre line "X";

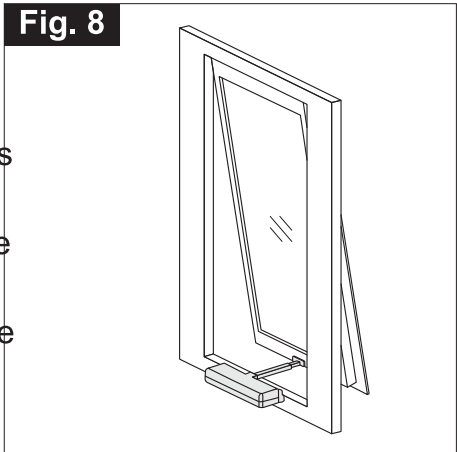

**CAUTION: FOR NON-COPLANAR WINDOW FRAMES, IT IS NECESSARY TO CUT THE ADHESIVE TEMPLATE CONCERNED PART AND TO APPLY IT ON THE WINDOW FRAME PAYING ATTENTION TO KEEP IT IN THE SAME REFERENCE POSITION.**

- 4) **Fig. 21-** With a suitable drill, create on the window frame holes having the related diameter, given on the adhesive template;
- 5) **Fig. 22÷24-** With the suitable screws tighten the brackets for window frame connection (right - left) and the quick coupling;
- 6) **Fig. 25/26-** After having connected the electric connector in the actuator, perform the electric connections according to the provisions of **par. 5.5**, as well as with reference to the wiring diagram. Let the chain come out for at least 5 cm of stroke, then disconnect the connector;
- 7) **Fig. 26-** Connect the chain end to the quick coupling;
- 8) **Fig. 27-** Fasten the actuator to the brackets for connection to the window frame using the suitable screws;



**VERIFY IN Fig. 7a THE CORRECT FASTENING POSITIONING OF THE ACTUATOR.**



**MAKE SURE THAT THE RED LABEL LOCATED ON THE QUICK COUPLING CORRESPONDS TO THE SAME LABEL ON THE ACTUATOR.**



**VERIFY THAT AFTER THE TIGHTENING THE CONNECTION BRACKETS TO THE WINDOW FRAME ADHERE TO THE ACTUATOR IN ORDER TO ASSURE A CORRECT APPLICATION.**

- 9) **Fig. 27-** Select the wished stroke (I= 240 mm - II= 360 mm) using the switch (**Ref. 1**) located on one side of the actuator. The actuator is supplied with the stroke set on 240 mm.



**TO CHANGE THE PRE-SET STROKE, USE A SCREWDRIVER (FIG. 27) WITH SUITABLE TIP. MAKE SURE TO INSERT THE TIP UP TO THE MICROSWITCH BASE AND TO SHIFT IT COMPLETELY. AN INCORRECT IN-BETWEEN POSITION STALLS THE ACTUATOR.**

- 10) **Fig. 25-** Insert the electric connector;



THE STROKE SELECTION HAS TO BE CARRIED OUT WITH SWITCHED OFF ACTUATOR ONLY BY COMPETENT AND QUALIFIED TECHNICAL PERSONNEL.



FOR A CORRECT ADJUSTMENT OF THE WINDOW FRAME CLOSING SEE THE INDICATIONS GIVEN IN PAR. 5.7.

### 5.3- BOTTOM HUNG WINDOWS (Fig. 9 and Fig. 28 ÷ 41)

- 1) Open the package (par. 3.7) and extract the various components;
- 2) Fig. 28- With a pencil draw the centre line "Y" of the window frame;
- 3) Fig. 29- Apply the adhesive template (Ref. 1) on the window frame aligning it with the previously drawn centre line "Y";

Fig. 9

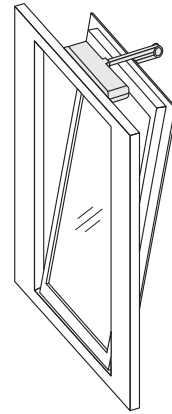

CAUTION: FOR NON-COPLANAR WINDOW FRAMES, IT IS NECESSARY TO CUT THE ADHESIVE TEMPLATE CONCERNED PART AND TO APPLY IT ON THE WINDOW FRAME PAYING ATTENTION TO KEEP IT IN THE SAME REFERENCE POSITION.

- 4) Fig. 30- With a suitable drill, create on the window frame holes having the related diameter, given on the adhesive template;
- 5) Fig. 31÷33- With the suitable screws tighten the brackets for window frame connection (right - left) and the bottom hung opening bracket;
- 6) Fig. 34/35- After having connected the electric connector in the actuator, perform the electric connections according to the provisions of par. 5.5, as well as with reference to the wiring diagram. Let the chain come out for at least 5 cm of stroke, then disconnect the connector;
- 7) Fig. 36- Connect the chain end to the bottom hung bracket;
- 8) Fig. 37- Fasten the actuator to the brackets for connection to the window frame using the suitable screws;



VERIFY IN Fig. 7b THE CORRECT FASTENING POSITIONING OF THE ACTUATOR.



VERIFY THAT AFTER THE TIGHTENING THE CONNECTION BRACKETS TO THE WINDOW FRAME ADHERE TO THE ACTUATOR IN ORDER TO ASSURE A CORRECT APPLICATION.

- 9) Fig. 37- Select the wished stroke (I= 240 mm - II= 360 mm) using the switch (Ref. 1) located on one side of the actuator. The actuator is supplied with a stroke set on 240 mm;



TO CHANGE THE PRE-SET STROKE, USE A SCREWDRIVER (FIG. 37) WITH SUITABLE TIP. MAKE SURE TO INSERT THE TIP UP TO THE MICROSWITCH BASE AND TO SHIFT IT COMPLETELY. AN INCORRECT IN-BETWEEN POSITION STALLS THE ACTUATOR.

10) Fig. 34- Insert the electric connector;



THE STROKE SELECTION HAS TO BE CARRIED OUT WITH SWITCHED OFF ACTUATOR ONLY BY COMPETENT AND QUALIFIED TECHNICAL PERSONNEL.



FOR A CORRECT ADJUSTMENT OF THE WINDOW FRAME CLOSING SEE THE INDICATIONS GIVEN IN PAR. 5.7.

#### 5.4- DOME WINDOWS (Fig. 10 and Fig. 38 ÷ 49)

- 1) Open the package (par. 3.7) and extract the various components;
- 2) Fig. 38- With a pencil draw the centre line "Z" of the window frame;
- 3) Fig. 39- Apply the adhesive template (Ref. 1) on the window frame aligning it with the previously drawn centre line "Z";

Fig.10

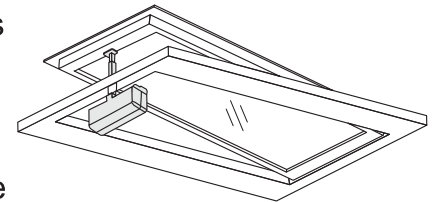

CAUTION: FOR NON-COPLANAR WINDOW FRAMES, IT IS NECESSARY TO CUT THE ADHESIVE TEMPLATE CONCERNED PART AND TO APPLY IT ON THE WINDOW FRAME PAYING ATTENTION TO KEEP IT IN THE SAME REFERENCE POSITION.

- 4) Fig. 40- With a suitable drill, create on the window frame holes having the related diameter, given on the adhesive template;
- 5) Fig. 41 ÷ 46- With the suitable screws, fasten the brackets for vertical assembly (Ref. A or Ref. B), the quick coupling and eventually the hole covering plate (Fig. 44 -Ref. 1);
- 6) Fig. 47/48- After having connected the electric connector in the actuator, perform the electric connections according to the provisions of par. 5.5, as well as with reference to the wiring diagram. Let the chain come out for at least 5 cm of stroke, then disconnect the connector;
- 7) Fig. 48- Connect the chain end to the quick coupling;
- 8) Fig. 49- Fasten the actuator to the brackets for vertical assembly (Ref. A or Ref. B) using the suitable screws;



VERIFY IN Fig. 7c THE CORRECT FASTENING POSITIONING OF THE ACTUATOR.



MAKE SURE THAT THE GREEN LABEL LOCATED ON THE QUICK COUPLING CORRESPONDS TO THE SAME LABEL ON THE ACTUATOR.



VERIFY THAT AFTER THE TIGHTENING THE CONNECTION BRACKETS TO THE WINDOW FRAME ADHERE TO THE ACTUATOR IN ORDER TO ASSURE A CORRECT APPLICATION.

9) **Fig. 49-** Select the wished stroke (I=240 mm - II=360 mm) using the switch (**Ref. 1**) located on one side of the actuator. The actuator is supplied with a stroke set on 240 mm.



**TO CHANGE THE PRE-SET STROKE, USE A SCREWDRIVER (FIG. 27) WITH SUITABLE TIP. MAKE SURE TO INSERT THE TIP UP TO THE MICROSWITCH BASE AND TO SHIFT IT COMPLETELY. AN INCORRECT IN-BETWEEN POSITION STALLS THE ACTUATOR.**

10) **Fig. 47-** Insert the electric connector;



**THE STROKE SELECTION HAS TO BE CARRIED OUT WITH SWITCHED OFF ACTUATOR ONLY BY COMPETENT AND QUALIFIED TECHNICAL PERSONNEL.**



**FOR A CORRECT ADJUSTMENT OF THE WINDOW FRAME CLOSING SEE THE INDICATIONS GIVEN IN PAR. 5.7.**

### 5.5- ELECTRIC CONNECTIONS (Wiring diagram)



THE CONNECTION OF MODEL MJ1/24V HAS TO BE CARRIED OUT WITH VERY LOW VOLTAGE SAFETY FEEDER PROTECTED AGAINST SHORT CIRCUIT.



THE ELECTRIC CONNECTION OF THE ACTUATOR CAN BE PERFORMED ONLY BY COMPETENT AND QUALIFIED TECHNICAL PERSONNEL FORESEEN BY THE LAW IN FORCE IN THE COUNTRY OF INSTALLATION WHO CAN ISSUE TO THE CUSTOMER A DECLARATION OF CONFORMITY FOR THE CONNECTION AND/OR PLANT CARRIED OUT.



BEFORE PERFORMING THE ELECTRIC CONNECTION OF THE ACTUATOR, VERIFY THE CORRECT INSTALLATION ON THE WINDOW.



THE MAINS TO WHICH THE ACTUATOR IS CONNECTED MUST COMPLY WITH THE REQUIREMENTS OF THE LAWS IN FORCE IN THE COUNTRY OF INSTALLATION, AS WELL AS SATISFY THE TECHNICAL FEATURES GIVEN IN TAB. 1 AND ON THE RATING PLATE AND THE “CE” MARKING (PAR. 3.1), AS WELL AS BE EQUIPPED WITH A SUITABLE “EARTHING PLANT”.



THE SECTION OF THE MAINS CABLES MUST BE PROPERLY SIZED ACCORDING TO THE ABSORBED ELECTRIC POWER (SEE RATING PLATE AND “CE” MARKING).



ANY TYPE OF ELECTRIC MATERIAL (PLUG, CABLE, TERMINALS, ETC.) USED FOR THE CONNECTION MUST BE SUITABLE FOR THE USE, WITH “CE” MARKING, AND COMPLYING WITH THE REQUIREMENTS FORESEEN BY THE LAWS IN FORCE IN THE COUNTRY OF INSTALLATION.



TO ASSURE AN EFFICIENT SEPARATION FROM THE MAINS, IT IS COMPULSORY TO INSTALL UPSTREAM OF THE DEVICE A TEMPORARY BIPOLAR SWITCH (PUSH-BUTTON) OF APPROVED TYPE. UPSTREAM OF THE COMMAND LINE, IT IS COMPULSORY TO INSTALL AN UNIPOLAR MAIN SWITCH WITH OPENING OF CONTACTS OF AT LEAST 3 mm.



BEFORE MAKING ANY ELECTRICAL CONNECTIONS ON THE ACTUATOR, MAKE SURE THE POWER SUPPLY CABLE IS NOT DAMAGED. IF THE CABLE IS DAMAGED, THEN IT MUST BE REPLACED BY THE MANUFACTURER THROUGH THE TECHNICAL ASSISTANCE SERVICE OR BY TECHNICAL OPERATORS.

### 5.6- COMMAND DEVICES



THE CONTROL DEVICES USED TO DRIVE THE ACTUATOR MUST ASSURE THE SAFETY CONDITIONS FORESEEN BY THE LAWS IN FORCE IN THE COUNTRY OF USE.

According to the different type of installations, the actuators can be driven by the following control devices:

#### 1) MANUAL PUSH-BUTTON:

Bipolar switch button with central OFF position, with biased-off switch



## 2) CONTROL AND FEEDING UNIT:

Microprocessor control units (e.g.: Mod. TF, etc.) controlling the single actuator or more than one actuator simultaneously by means of one or more manual push-buttons, an infrared remote control or a 433 Mhz radio control.

To these control units, it is possible to connect rain sensors(**RD - 12V**), wind sensor (**RW**) and brightness sensor.



**TO ASSURE A CORRECT OPERATION OF THE ACTUATOR, THE COMMAND AND FEEDING UNITS EVENTUALLY USED HAVE TO PROVIDE POWER SUPPLY TO THE ACTUATOR FOR MAX. 120 sec.**



**BEFORE OPERATING THE ACTUATOR, THE USER MUST COMPULSORILY VERIFY THAT NEAR AND/OR UNDER THE WINDOW THERE ARE NOT ANY PERSON, ANIMAL AND THING WHOSE SAFETY MAY BE ACCIDENTALLY JEOPARDISED (SEE PAR. 4.4).**

## 5.7- CORRECT ASSEMBLY OF THE ACTUATOR ON THE WINDOW FRAME



**THE CORRECT ADJUSTMENT OF THE WINDOW FRAME CLOSING ASSURES THE LIFE AND THE TIGHTNESS OF THE SEALS, AS WELL AS THE GOOD OPERATION OF THE ACTUATOR.**

- 1) With open window frame, verify that the selected stroke is some centimetre lower than the stroke limited by window frame mechanical limit devices;



**VERIFY THAT THE CHAIN END IS ON THE SAME AXIS OF THE QUICK COUPLING. OTHERWISE, LOOSEN THE TIGHTENING SCREWS AND POSITION CORRECTLY. WHEN THE DEVICES ARE NOT COAXIAL, DAMAGES TO THE ACTUATOR AND THE WINDOW FRAME MAY ARISE (FIG. 11).**

- 2) Verify that the two support brackets of the actuator are aligned to each other and the four tightening screws are well tightened. Between the two brackets and the actuator there must not be any clearance.

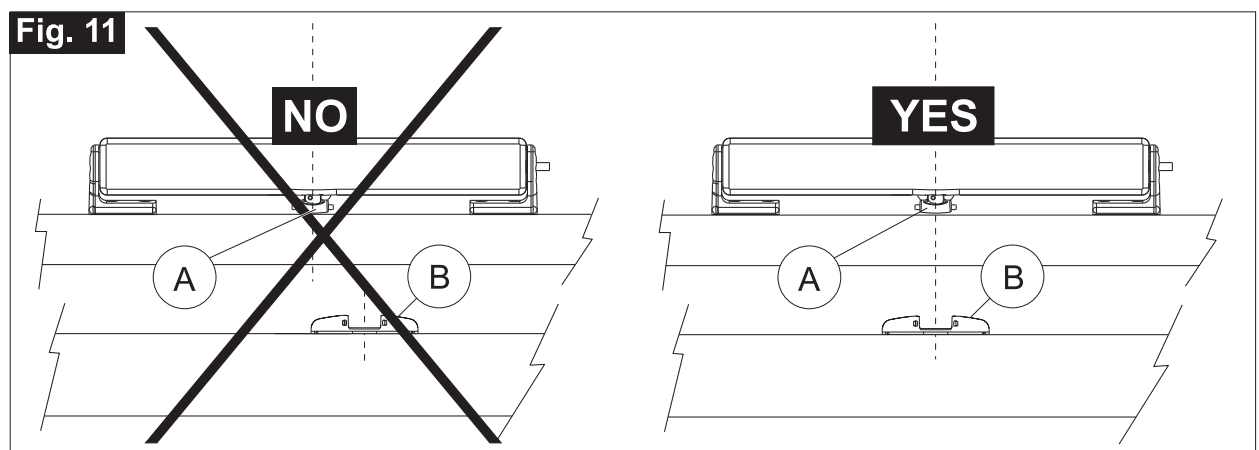

### 5.8- EMERGENCY PROCEDURES

Should it be necessary to close the window manually, due to power supply failure or mechanism block, follow these instructions:



**BEFORE PERFORMING ANY TYPE OF TRIPPING ON THE ACTUATOR AND ON THE WINDOW, IT IS COMPULSORY TO DISCONNECT THE POWER SUPPLY OF THE ACTUATOR AND TO PUT ON "0" THE EVENTUAL SWITCHES OF THE CONTROL DEVICES.**



**IT IS COMPULSORY TO PADLOCK THE MAIN SWITCH OF THE DISCONNECTION DEVICE INSTALLED ON THE MAINS IN ORDER TO AVOID ANY UNEXPECTED START. IF THE MAIN SWITCH CANNOT BE PADLOCKED, IT IS COMPULSORY TO PLACE A SIGN FORBIDDING THE ENABLING.**

- **Top hung: Fig. 12-** Insert the release tool (**Ref. 1**) in the openings (**Ref. 2**) as shown in figure, disconnect the chain end from the ARS coupling and extract the actuator;
- **Bottom hung opening: Fig. 13-** Insert a screwdriver between the bottom hung opening bracket and the chain end, then lever until the chain end is released from the above mentioned bracket.



**SHOULD IT BE IMPOSSIBLE TO CARRY OUT THE ABOVE MENTIONED MANOEUVRES, EXTRACT THE ACTUATOR FROM THE BRACKETS PROVIDING CONNECTION TO THE FRAME BY UNSCREWING THE PROPER SCREWS.**

**Fig. 12**

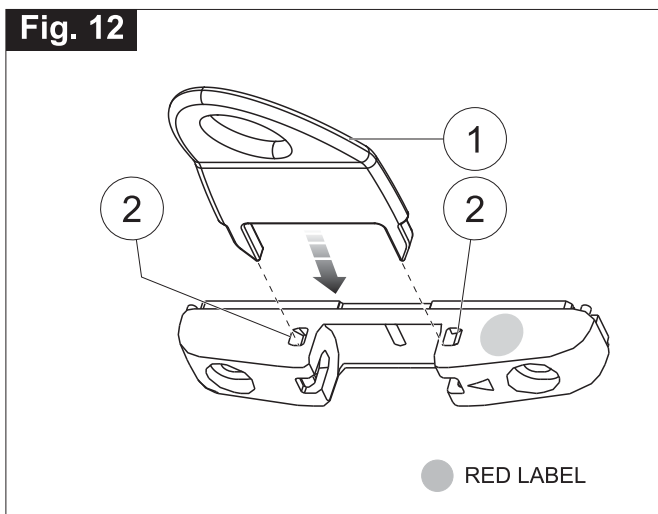

**Fig. 13**

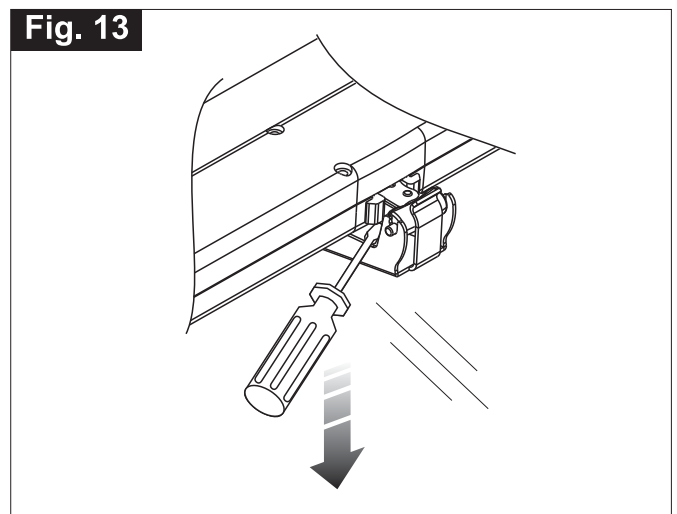

## 6.1- USE OF THE ACTUATOR



THE ACTUATOR CAN BE USED EXCLUSIVELY BY AN USER ACTING IN COMPLIANCE WITH THE INSTRUCTIONS CONTAINED IN THIS MANUAL AND/OR IN THE MANUAL OF THE ACTUATOR CONTROL DEVICE (e.g.: WIND AND RAIN CONTROL UNIT).



BEFORE USING THE ACTUATOR, IT IS COMPULSORY FOR THE USER TO READ AND UNDERSTAND IN ALL ITS PARTS THIS MANUAL, AS WELL AS THE EVENTUAL MANUAL OF THE INSTALLED CONTROL DEVICE TYPE.



BEFORE OPERATING THE ACTUATOR, THE USER MUST COMPULSORILY VERIFY THAT NEAR AND/OR UNDER THE WINDOW THERE ARE NOT ANY PERSON, ANIMAL AND THING WHOSE SAFETY MAY BE ACCIDENTALLY JEOPARDISED (SEE PAR. 4.4).



DURING THE OPERATION OF THE ACTUATOR CONTROL DEVICE, THE USER HAS TO COMPULSORY OCCUPY A SAFE CONTROL POSITION ASSURING VISUAL CONTROL ON THE WINDOW MOVEMENT.



IT IS COMPULSORY TO VERIFY CONSTANTLY IN TIME THE FUNCTIONAL EFFICIENCY AND THE RATED PERFORMANCE OF THE ACTUATOR, OF THE WINDOW FRAME WHERE IT IS INSTALLED AND OF THE ELECTRIC PLANT, PERFORMING WHEN NECESSARY INTERVENTIONS OF ROUTINE OR SUPPLEMENTARY MAINTENANCE ASSURING OPERATION CONDITIONS COMPLYING WITH SAFETY REGULATIONS.



ALL ABOVE MENTIONED MAINTENANCE INTERVENTIONS CAN BE PERFORMED ONLY BY COMPETENT AND QUALIFIED TECHNICAL PERSONNEL MEETING THE PROFESSIONAL AND TECHNICAL REQUIREMENTS FORESEEN BY THE LAW IN FORCE IN THE COUNTRY OF INSTALLATION.

The use of the actuator allows to control automatically the opening and closing of the window according to the type of control device installed (see par. 5.6).

**7.1- GENERAL INSTRUCTIONS**

**IF THE ACTUATOR WORKS INCORRECTLY, CONTACT THE MANUFACTURER.**



**ANY WORK ON THE ACTUATOR (E.G.: POWER CABLE, ETC.) OR ITS COMPONENTS MAY ONLY BE CARRIED OUT BY PERSONNEL QUALIFIED BY THE MANUFACTURER. STATEUROP DECLINES ALL LIABILITY FOR WORK PERFORMED BY UNAUTHORISED PEOPLE**

The actuator incorporates components that do not require significant routine or extraordinary maintenance operations.

In heavy-duty conditions (e.g.: very dirty work areas, frequent use, elevated temperature changes, load variations caused by wind or snow, etc.) make sure, at least once every 6 months, that the actuator assembly components are clean, the fixing systems (brackets and screws) are tight, the window frame is not deformed and the seals are tight, and check the cables and connectors.

If any malfunctions arise after cleaning or inspection, contact the STATEUROP technical assistance service.

**8.1- GENERAL INSTRUCTIONS**

**THE DEMOLITION OF THE ACTUATOR MUST OCCUR IN COMPLIANCE WITH THE LAWS IN FORCE ON ENVIRONMENT PROTECTION.**



**DIFFERENTIATE THE PARTS MAKING UP THE ACTUATOR ACCORDING TO THEIR DIFFERENT MATERIAL TYPE (PLASTIC, ALUMINIUM, ETC.).**

## 9.1- GENERAL INSTRUCTIONS



THE USE OF “NON-ORIGINAL” SPARE PARTS AND ACCESSORIES WHICH MAY ENDANGER THE SAFETY AND THE EFFICIENCY OF THE ACTUATOR IS FORBIDDEN. THIS ACTION SHALL INVOLVE THE WARRANTY EXPIRATION.



ORIGINAL SPARE PARTS AND ACCESSORIES HAVE TO BE REQUESTED EXCLUSIVELY TO YOUR DEALER OR TO THE MANUFACTURER STATING TYPE, MODEL, SERIAL NUMBER, AND YEAR OF CONSTRUCTION OF THE ACTUATOR.



IN CASE OF REPLACEMENT OF THE POWER SUPPLY CABLE, IT IS NECESSARY TO USE A CABLE TYPE HOS-VVF 3 x 0.75.



THE REPLACEMENT CAN BE PERFORMED EXCLUSIVELY BY COMPETENT AND QUALIFIED TECHNICAL PERSONNEL MEETING THE PROFESSIONAL AND TECHNICAL REQUIREMENTS FORESEEN BY THE LAWS IN FORCE IN THE COUNTRY OF INSTALLATION.

## 9.2 - BRACKETS FOR VERTICAL ASSEMBLY

**Fig. 14**

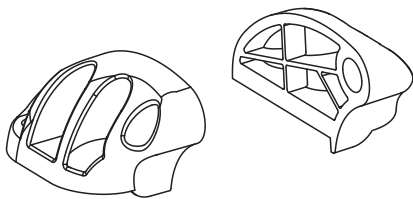

**Fig. 15**

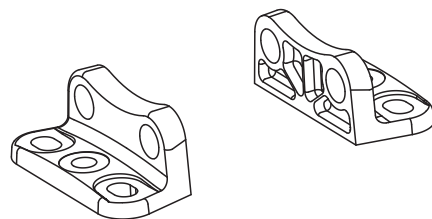

### 9.3 - QUICK COUPLING WITH INTEGRATED RELEASE PUSH-BUTTON "ARP"

This connection allows the application in case of top hung and dome assemblies. Unlike the quick coupling to the frame (**ARS**) inserted in the standard supply, the ARP is equipped with a push-button (**Fig. 16 - Ref. 1**) for the quick release in case of emergency manoeuvres.

CODES TO ORDER THE ARP		
CODE	COLOUR	TYPE OF APPLICATION
1UA015	Black	DOME/SKYLIGHT (Vertical assembly application)
1UA016	White	
1UA017	Grey	

#### 9.3.1- DOME WINDOWS (Fig. 16 ÷ 18, Fig. 10)

Follow the procedure described in **par. 5.4** up to **Fig. 42**, and then correctly position the ARP coupling on the frame as shown in **Fig. 17**.

**Fig. 16**

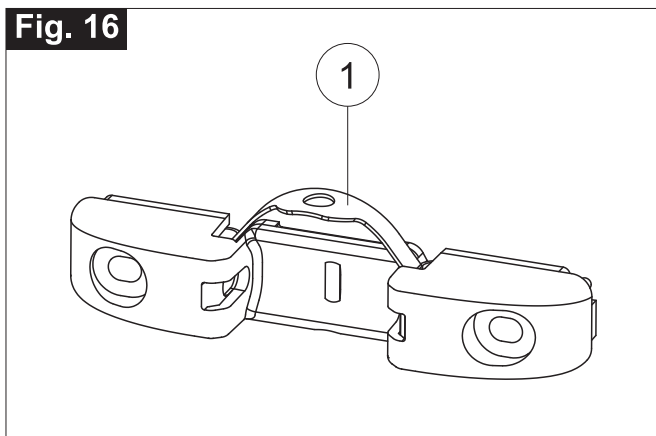

**Fig. 17**

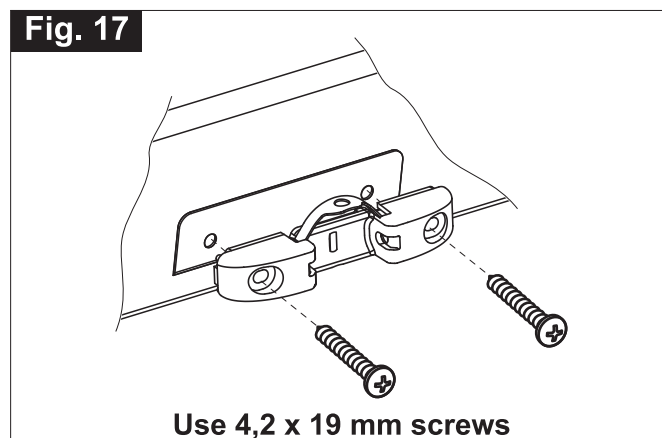

### 9.3.2- EMERGENCY MANOEUVRES (Fig. 18)

Should it be necessary to close the window manually, due to power supply failure or mechanism block, follow these instructions:



**BEFORE PERFORMING ANY TYPE OF INTERVENTION ON THE ACTUATOR AND ON THE WINDOW, IT IS COMPULSORY TO DISCONNECT THE POWER SUPPLY OF THE ACTUATOR AND TO SET ON "0" THE EVENTUAL SWITCHES OF THE CONTROL DEVICES.**



**IT IS COMPULSORY TO PADLOCK THE MAIN SWITCH OF THE DISCONNECTION DEVICE INSTALLED ON THE MAINS IN ORDER TO AVOID ANY UNEXPECTED START. IF THE MAIN SWITCH CANNOT BE PADLOCKED, IT IS COMPULSORY TO PLACE A SIGN FORBIDDING THE ENABLING.**

• **Fig. 18-** Press the push-button (Ref. 1) to release the chain end, and therefore to allow the release of the actuator.



**SHOULD IT BE IMPOSSIBLE TO REACH THE PUSH-BUTTON AND PERFORM THE ABOVE MENTIONED PROCEDURE, EXTRACT THE ACTUATOR FROM THE BRACKETS PROVIDING CONNECTION TO THE ACTUATOR UNSCREWING THE PROPER SCREWS.**

**Fig. 18**

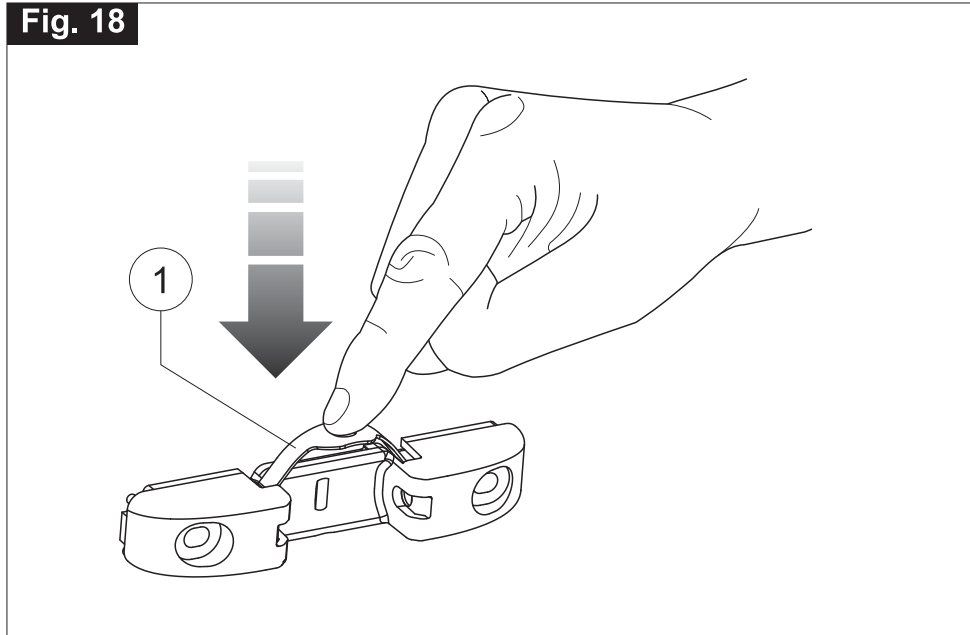

Fig. 19

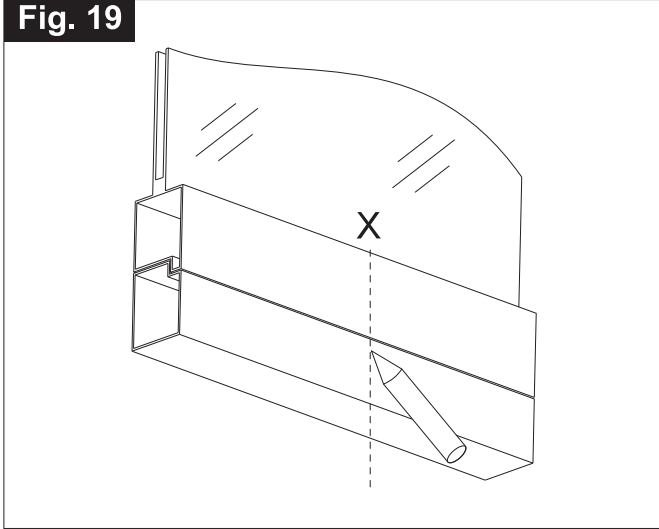

Fig. 20

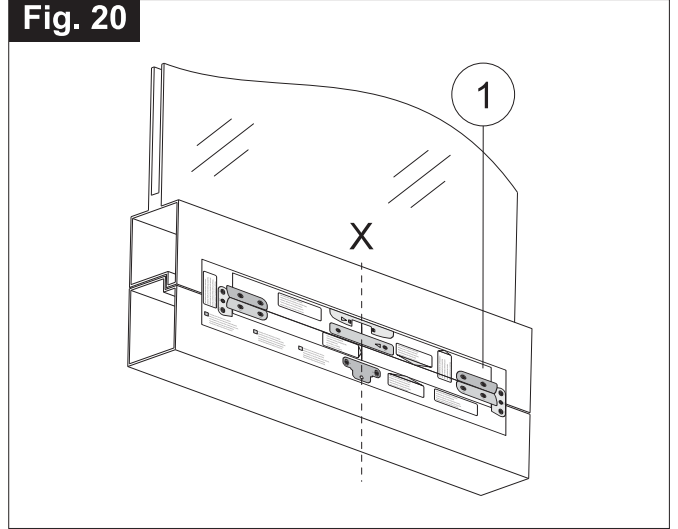

Fig. 21

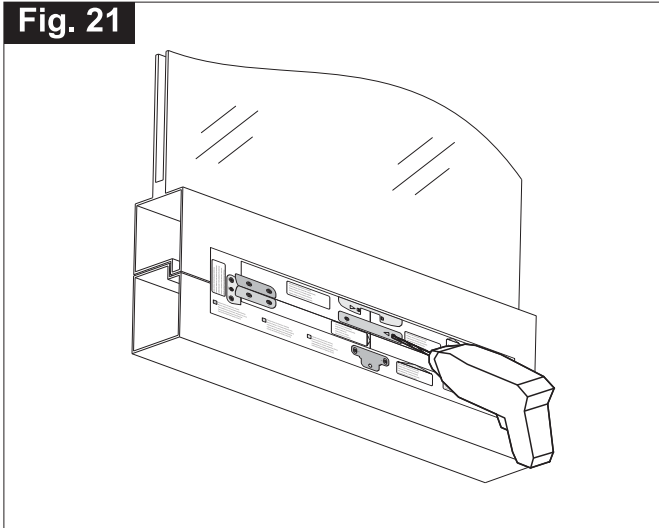

Fig. 22

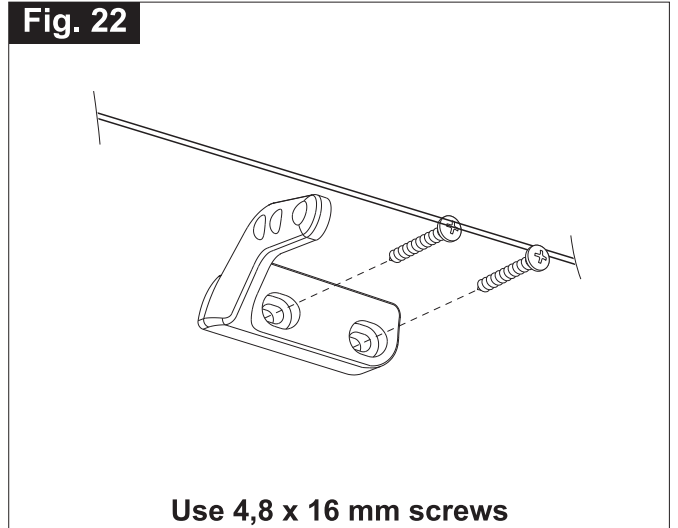

Fig. 23

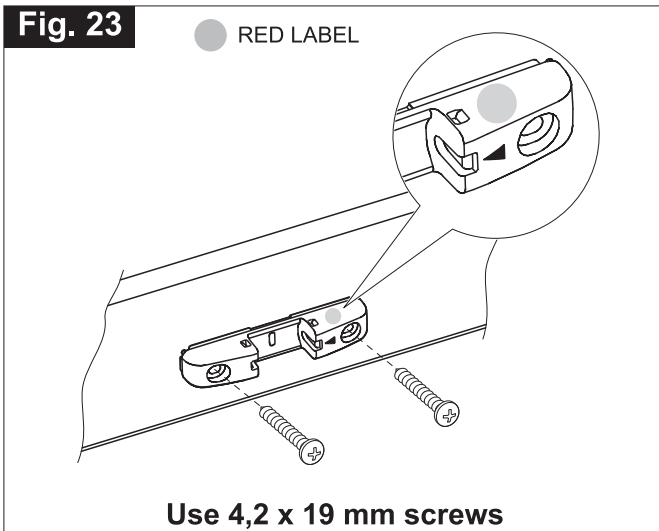

Fig. 24

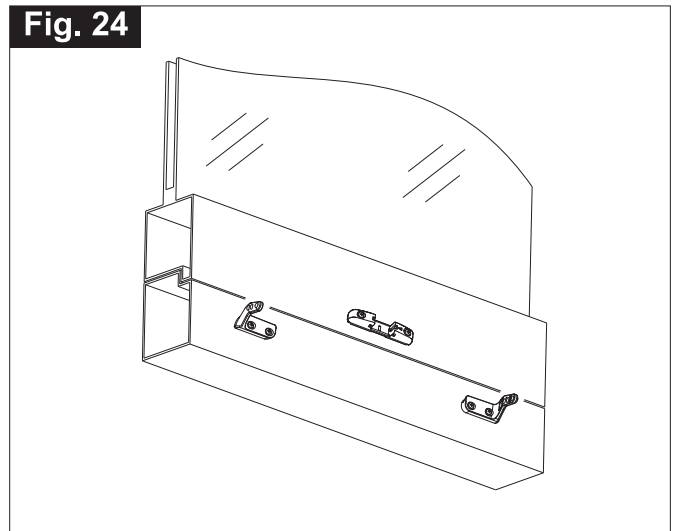



Fig. 25

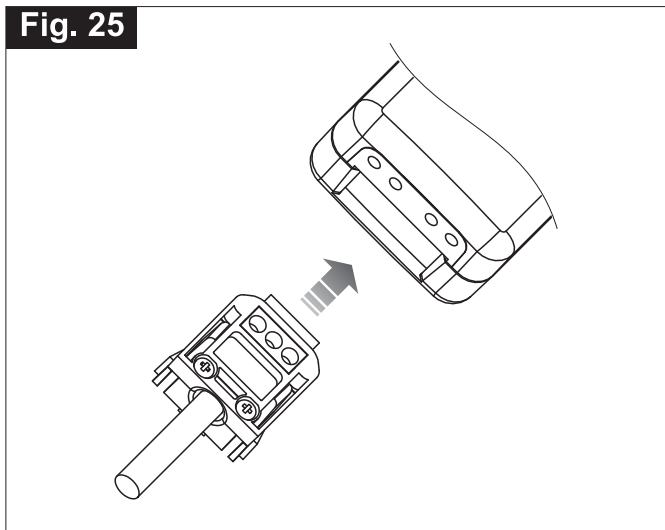

Fig. 26

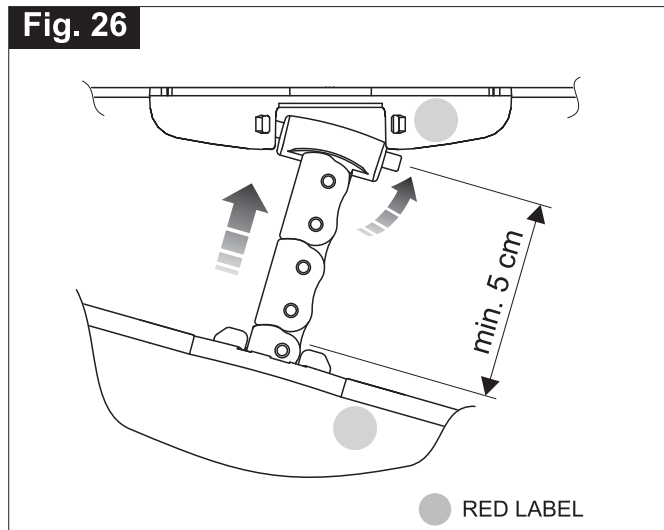

Fig. 27

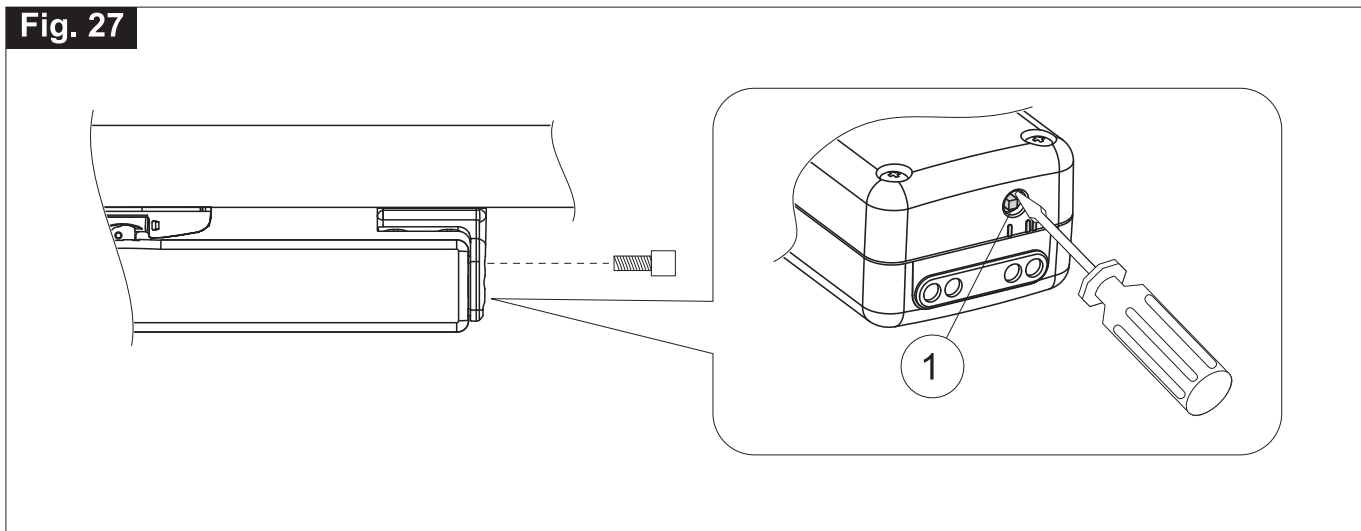

Fig. 28

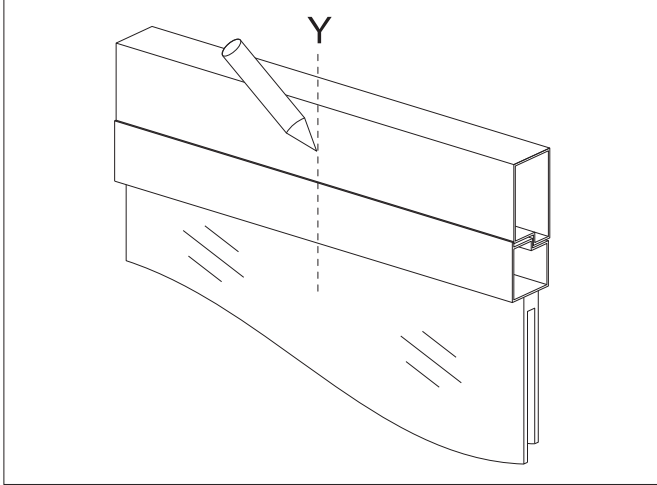

Fig. 29

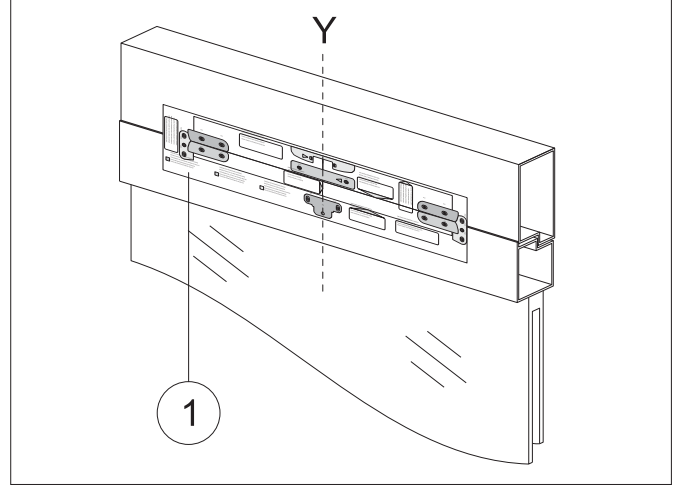

Fig. 30

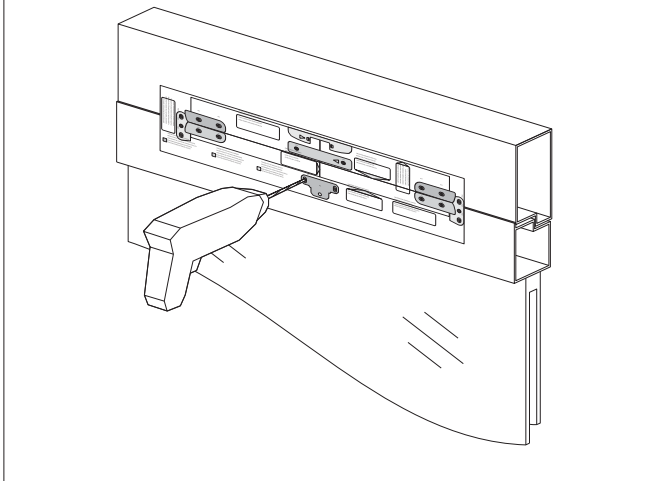

Fig. 31

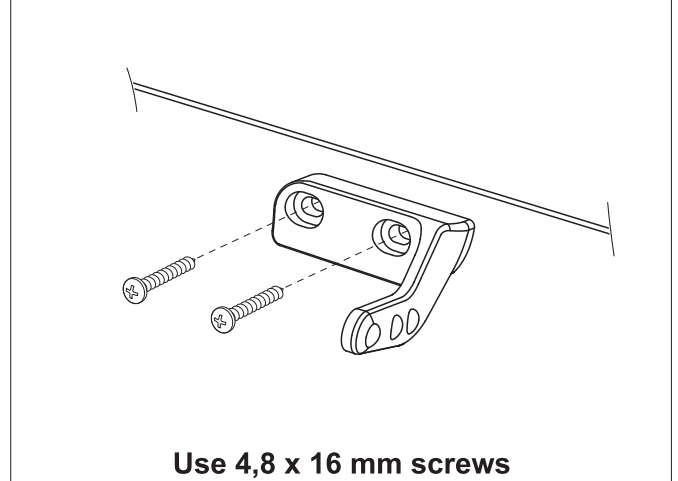

Fig. 32

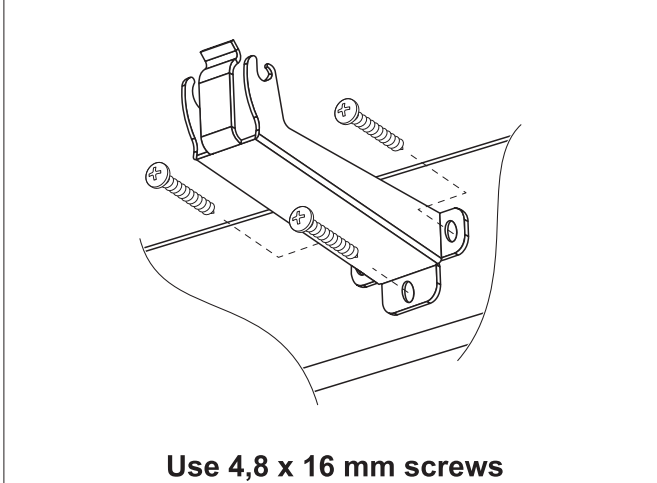

Fig. 33

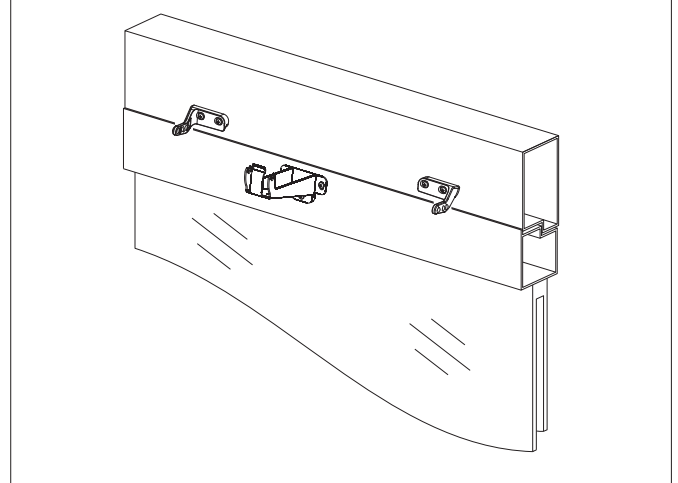

Fig. 34

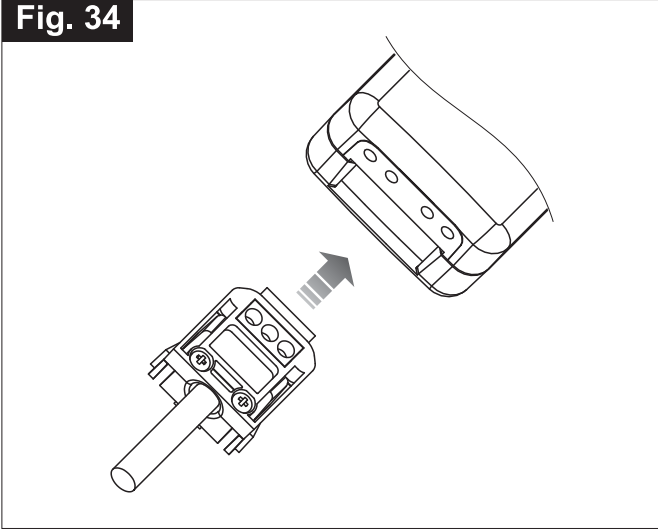

Fig. 35

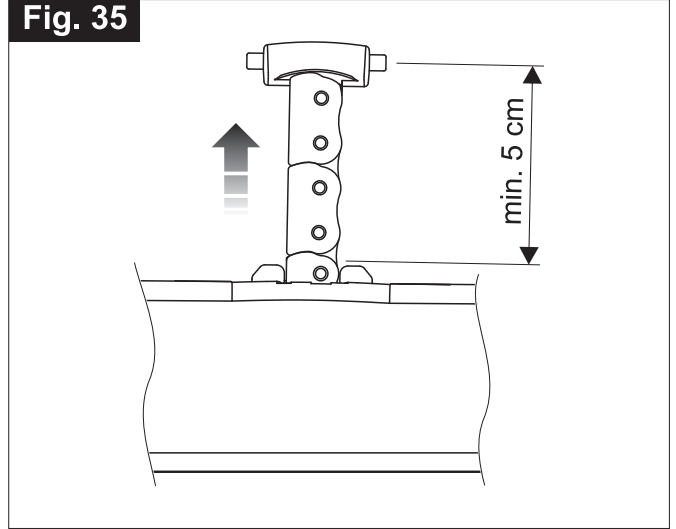

Fig. 36

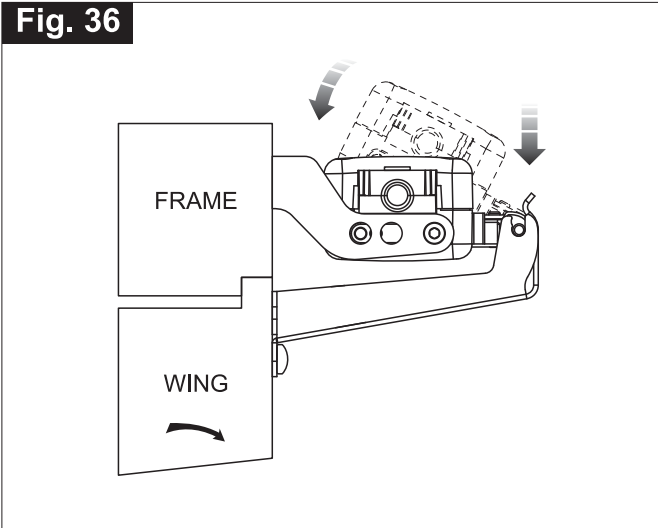
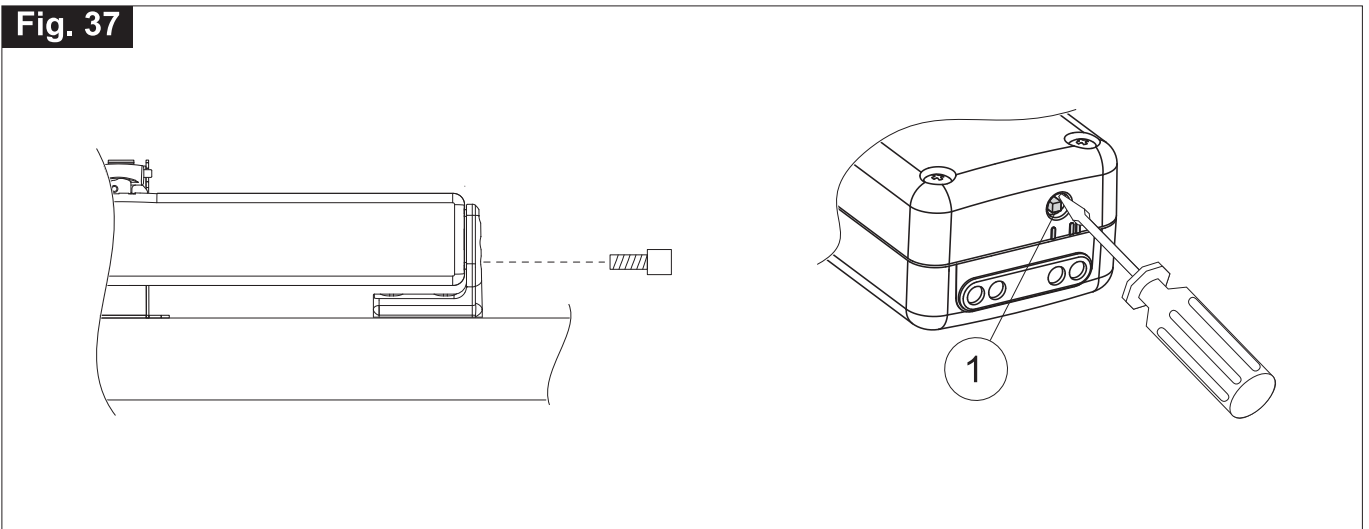
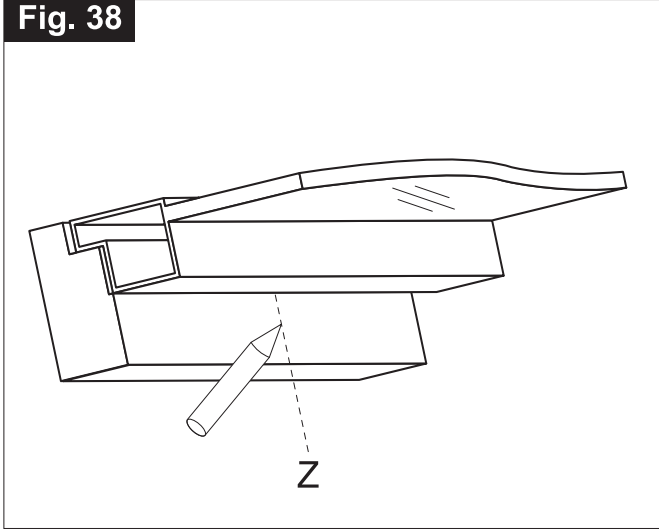

Fig. 37



**Fig. 38**



**Fig. 39**

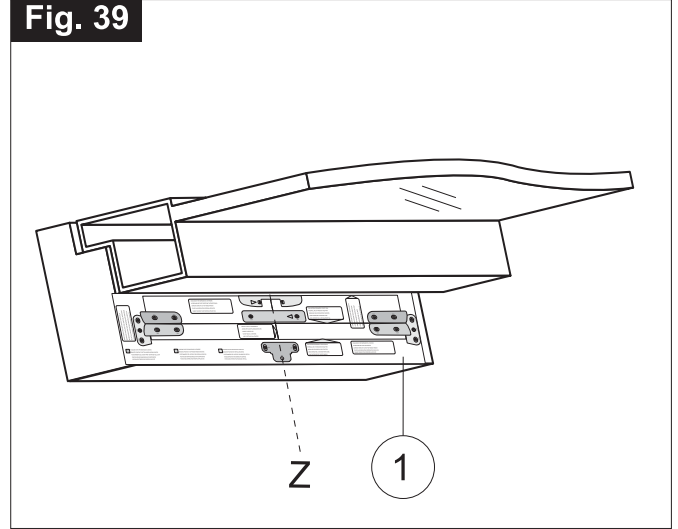

**Fig. 40**

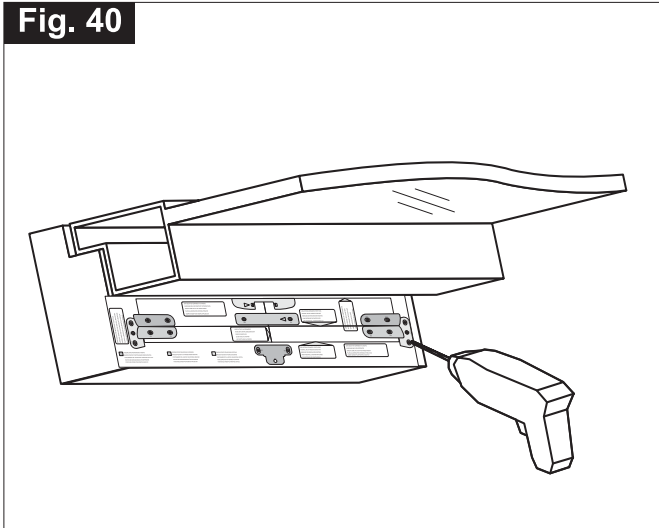

**Fig. 41**

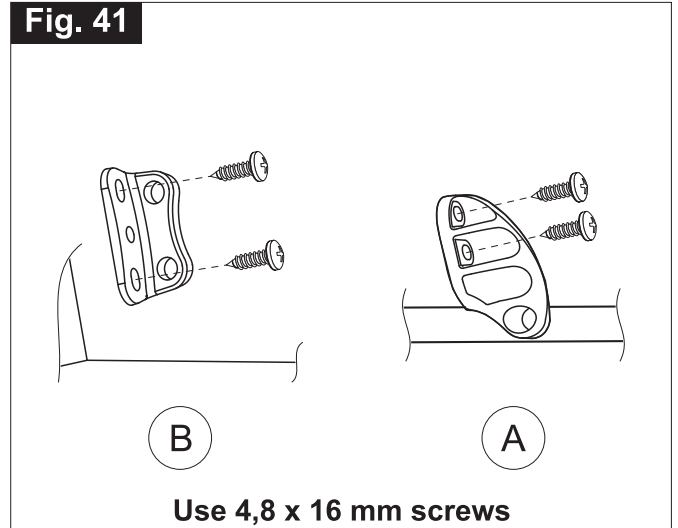

**Fig. 42**

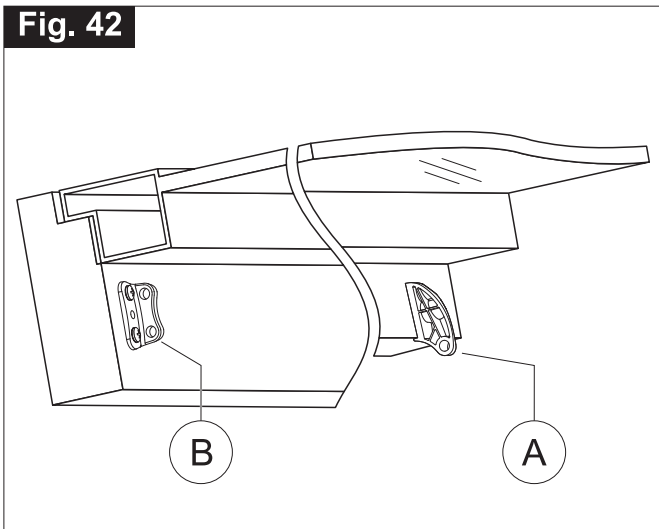

**Fig. 43**

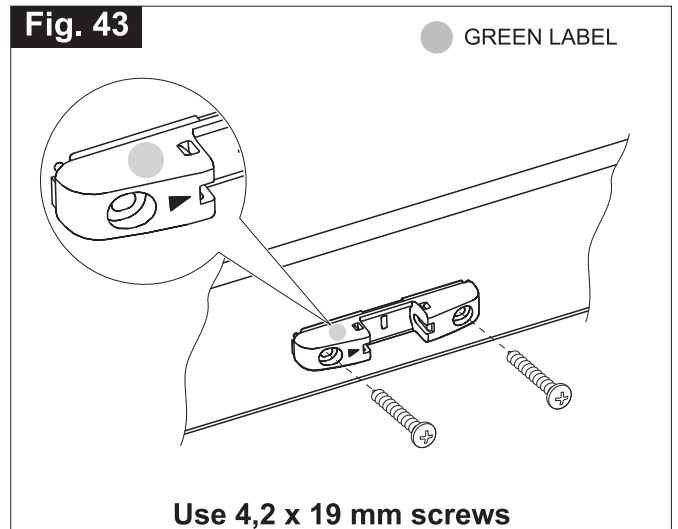

Fig. 44

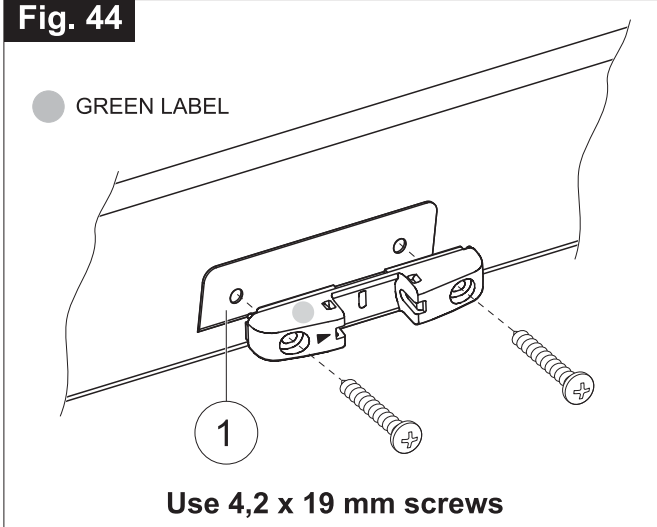

Fig. 45

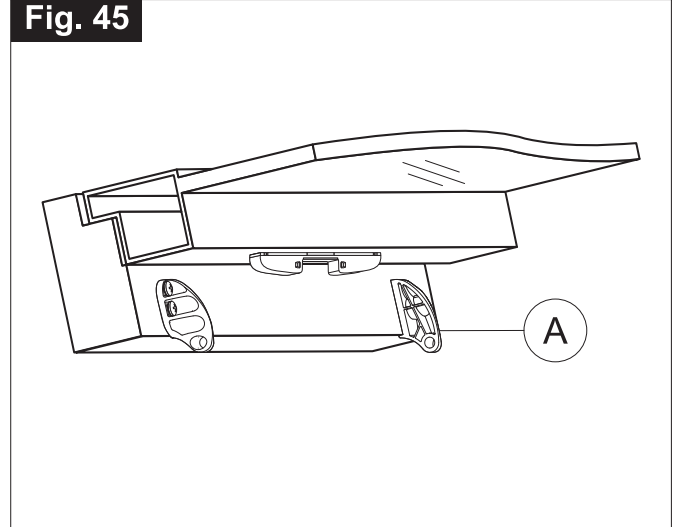

Fig. 46

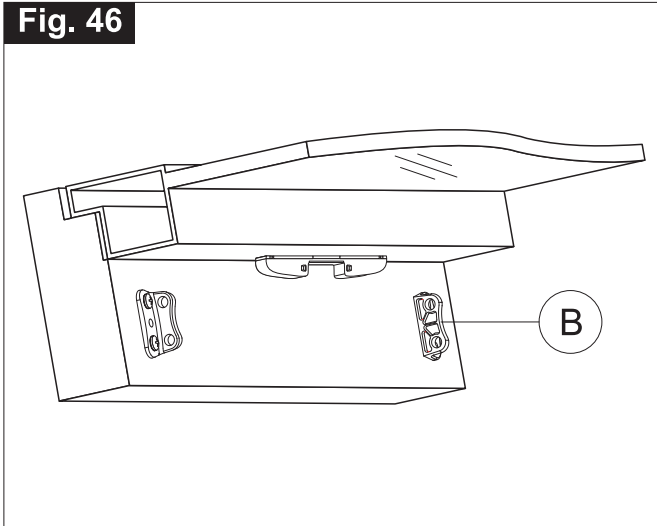

Fig. 47

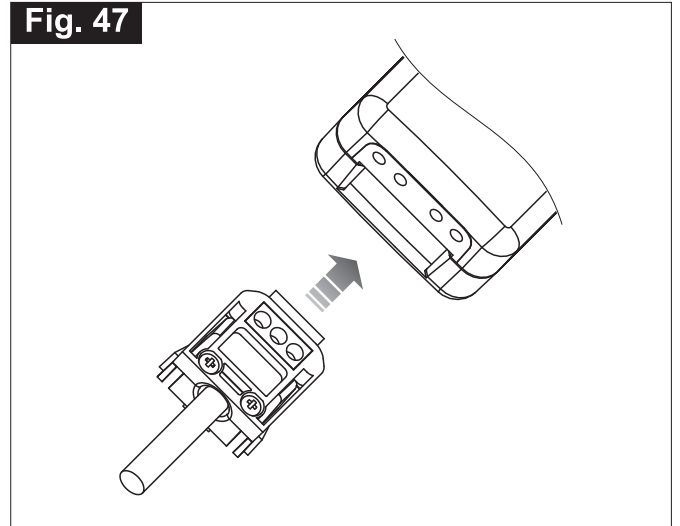

Fig. 48

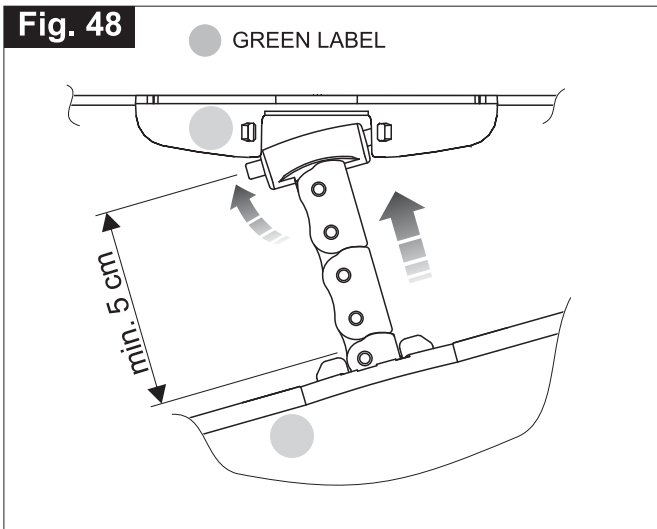
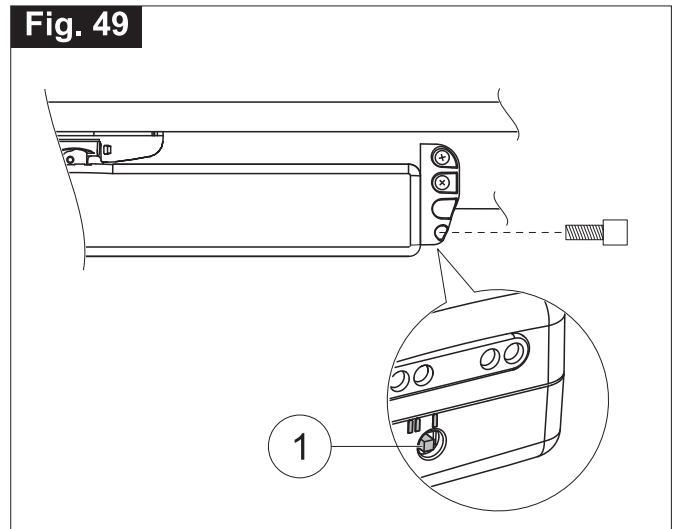
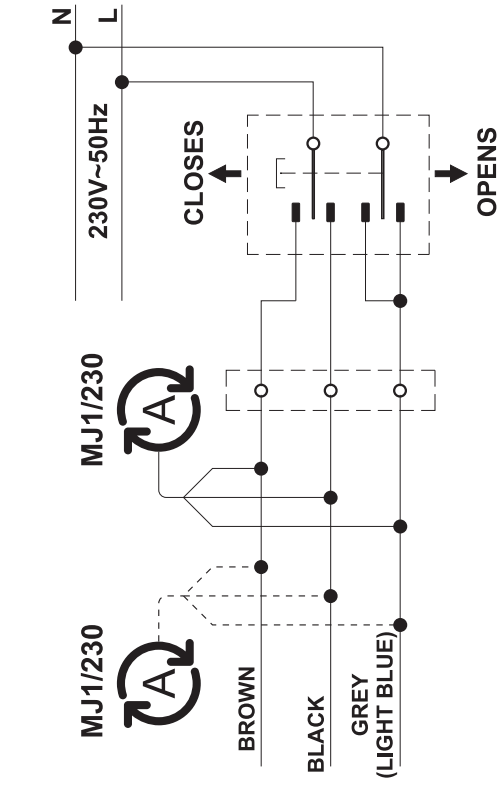

Fig. 49



230 V

Wiring diagram



THIS SYMBOL IDENTIFIES THE STATEUROPE ELECTRICAL ACTUATOR IN WIRING DIAGRAM

24 V

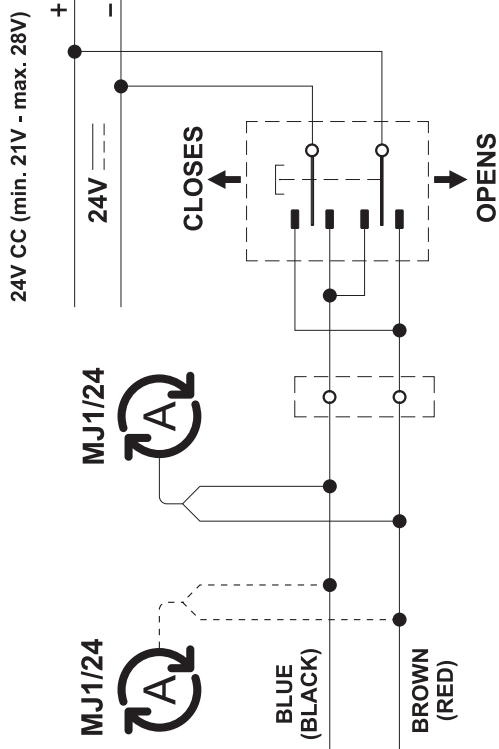

THIS SYMBOL IDENTIFIES THE STATEUROPE ELECTRICAL ACTUATOR IN WIRING DIAGRAM

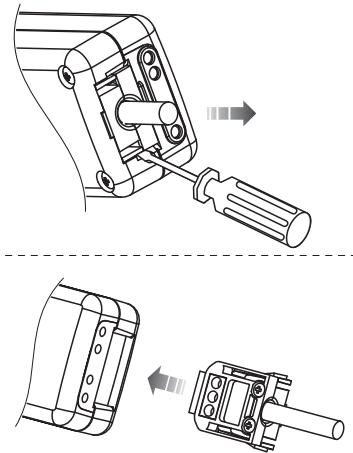
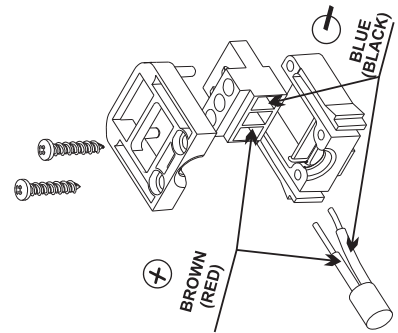
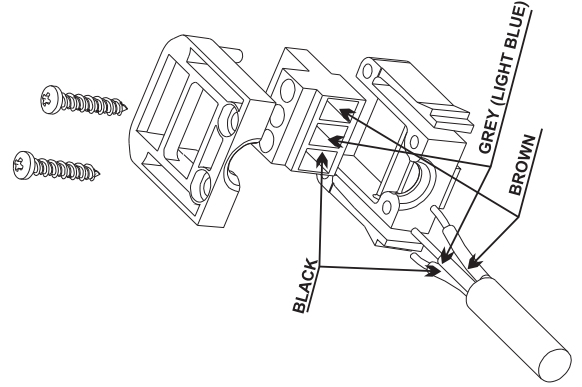

Warranty for faults or defects according to art. 1490 of the Civil Code covers products and single parts of products for 24 months after the shipment from the factory.

Warranty for the good operative performance of devices agreed by the manufacturer means that the manufacturer will commit itself to repair and replace, free of charge and as soon as possible, the parts that may be fail due to a material manufacturing defect during the warranty period. The buyer cannot be entitled to any compensation right for any damages or other expenses. Fragile parts or parts that are exposed to normal wear and tear or that are exposed to corrosive agents or treatments or to overloads, even if just temporary, etc, are not included in the warranty. The manufacturer will not be liable for any damages caused by incorrect assembling, handling, fitting, excessive stress or damages due to incompetence.

Furthermore, the manufacturer will not be liable for tampering with the product, if the product is disassembled or lacks a label or if it has obvious indications of collision or other. Repairs under warranty should always be delivered under "ex-works" terms. The buyer will always be liable for transportation costs (inward and outward). The manufacturer will be liable for any specialized personnel inspection labour costs, except for places that cannot be easily inspected and that require further verification costs and maintenance. In any case, transportation costs (inward/outward), travelling hours and board and lodging costs shall be reimbursed.

**The warranty is valid only if the form herein (which is part of the usage and installation instructions) is filled out completely and specified with the reason of the reported fault.**

The products must be installed and used in accordance with the technical characteristics and instructions provided by STATEUROP and also according to the compliance of safety norms and dispositions that regulate the installation and the use of the electric appliances, effective in the country in which the products are installed and used. To that end, the buyer explicitly exempts STATEUROP from any liability with regard to improper usage, the non-compliance of safety norms, technical specifications and use and installation instructions.

MODEL	_____	TECHNICAL REPORT								
SERIAL No.	<table border="1" style="display: inline-table; border-collapse: collapse;"> <tr> <td style="width: 20px; height: 20px;"></td> <td style="width: 20px; height: 20px;"></td> <td style="width: 20px; height: 20px;"></td> <td style="width: 20px; height: 20px;"></td> <td style="width: 20px; height: 20px;"></td> <td style="width: 20px; height: 20px;"></td> <td style="width: 20px; height: 20px;"></td> <td style="width: 20px; height: 20px;"></td> </tr> </table>									_____
CUSTOMER	_____	_____								
ADDRESS	_____ _____	_____								
RETAILER'S NAME (STAMP AND SIGNATURE)		_____								
		_____								
		_____								
		_____								
		_____								
		_____								
		_____								
		_____								
		_____								
		_____								

