

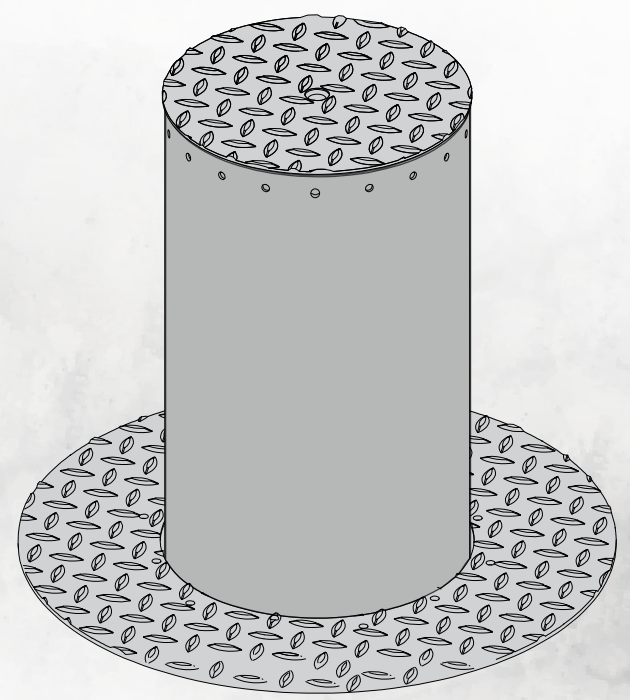

MPIE10

INSTALLER AND USER'S MANUAL

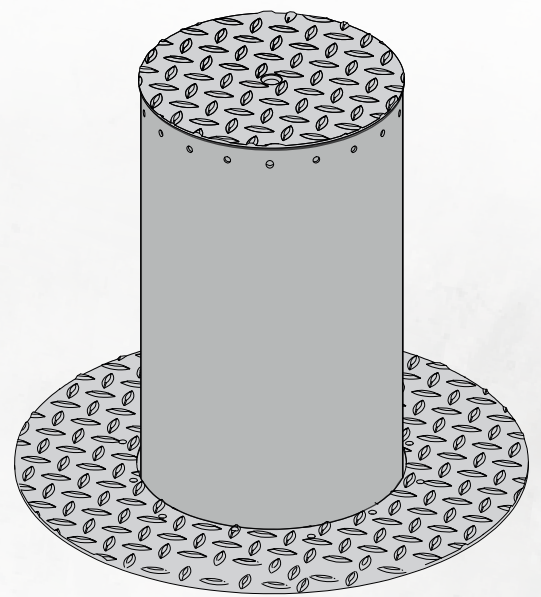



00. CONTENT

INDEX

01. SAFETY INSTRUCTIONS	1B
02. AUTOMATISM	
TECHNICAL CHARACTERISTICS	4A
MANUAL UNLOCKING	4A
KIT COMPONENTS	4A
DIMENSIONS	4B
03. INSTALLATION	
AUTOMATISM INSTALLATION	6A
04. TROUBLESHOOTING	
INSTRUCTIONS FOR FINAL CONSUMERS AND SPECIALIZED TECHNICIANS	7

01. SAFETY INSTRUCTIONS

ATENÇÃO

	This product is certified in accordance with European Community (EC) safety standards.
RoHS	This product complies with Directive 2011/65/EU of the European Parliament and of the Council, of 8 June 2011, on the restriction of the use of certain hazardous substances in electrical and electronic equipment and with Delegated Directive (EU) 2015/863 from Commission.
	(Applicable in countries with recycling systems). This marking on the product or literature indicates that the product and electronic accessories (eg. Charger, USB cable, electronic material, controls, etc.) should not be disposed of as other household waste at the end of its useful life. To avoid possible harm to the environment or human health resulting from the uncontrolled disposal of waste, separate these items from other types of waste and recycle them responsibly to promote the sustainable reuse of material resources. Home users should contact the dealer where they purchased this product or the National Environment Agency for details on where and how they can take these items for environmentally safe recycling. Business users should contact their vendor and check the terms and conditions of the purchase agreement. This product and its electronic accessories should not be mixed with other commercial waste.
	This marking indicates that the product and electronic accessories (eg. charger, USB cable, electronic material, controls, etc.) are susceptible to electric shock by direct or indirect contact with electricity. Be cautious when handling the product and observe all safety procedures in this manual.

01. SAFETY INSTRUCTIONS

GENERAL WARNINGS

- This manual contains very important safety and usage information. very important. Read all instructions carefully before beginning the installation/usage procedures and keep this manual in a safe place that it can be consulted whenever necessary.
- This product is intended for use only as described in this manual. Any other enforcement or operation that is not mentioned is expressly prohibited, as it may damage the product and put people at risk causing serious injuries.
- This manual is intended firstly for specialized technicians, and does not invalidate the user's responsibility to read the "User Norms" section in order to ensure the correct functioning of the product.
- The installation and repair of this product may be done by qualified and specialized technicians, to assure every procedure are carried out in accordance with applicable rules and norms. Nonprofessional and inexperienced users are expressly prohibited of taking any action, unless explicitly requested by specialized technicians to do so.
- Installations must be frequently inspected for unbalance and the wear signals of the cables, springs, hinges, wheels, supports and other mechanical assembly parts.
- Do not use the product if it is necessary repair or adjustment is required.
- When performing maintenance, cleaning and replacement of parts, the product must be disconnected from power supply. Also including any operation that requires opening the product cover.
- The use, cleaning and maintenance of this product may be carried out by any persons aged eight years old and over and persons whose physical, sensorial or mental capacities are lower, or by persons without any knowledge of the product, provided that these are supervision and instructions given by persons with experienced in terms of usage of the product in a safe manner and who understands the risks and dangers involved.

- Children shouldn't play with the product or opening devices to avoid the motorized door or gate from being triggered involuntarily.

WARNINGS FOR TECHNICIANS

- Before beginning the installation procedures, make sure that you have all the devices and materials necessary to complete the installation of the product.
- You should note your Protection Index (IP) and operating temperature to ensure that is suitable for the installation site.
- Provide the manual of the product to the user and let them know how to handle it in an emergency.
- If the automatism is installed on a gate with a pedestrian door, a door locking mechanism must be installed while the gate is in motion.
- Do not install the product "upside down" or supported by elements do not support its weight. If necessary, add brackets at strategic points to ensure the safety of the automatism.
- Do not install the product in explosive site.
- Safety devices must protect the possible crushing, cutting, transport and danger areas of the motorized door or gate.
- Verify that the elements to be automated (gates, door, windows, blinds, etc.) are in perfect function, aligned and level. Also verify if the necessary mechanical stops are in the appropriate places.
- The central must be installed on a safe place of any fluid (rain, moisture, etc.), dust and pests.
- You must route the various electrical cables through protective tubes, to protect them against mechanical exertions, essentially on the power supply cable. Please note that all the cables must enter the central from the bottom.
- If the automatism is to be installed at a height of more than 2,5m from the ground or other level of access, the minimum safety and health requirements for the use of work equipment workers at the work of Directive 2009/104/CE of European Parliament and of the Council of 16

01. SAFETY INSTRUCTIONS

September 2009.

- Attach the permanent label for the manual release as close as possible to the release mechanism.
- Disconnect means, such as a switch or circuit breaker on the electrical panel, must be provided on the product's fixed power supply leads in accordance with the installation rules.
- If the product to be installed requires power supply of 230Vac or 110Vac, ensure that connection is to an electrical panel with ground connection.
- The product is only powered by low voltage safety with central (only at 24V motors)

WARNINGS FOR USERS

- Keep this manual in a safe place to be consulted whenever necessary.
- If the product has contact with fluids without being prepared, it must immediately disconnect from the power supply to avoid short circuits, and consult a specialized technician.
- Ensure that technician has provided you the product manual and informed you how to handle the product in an emergency.
- If the system requires any repair or modification, unlock the automatism, turn off the power and do not use it until all safety conditions have been met.
- In the event of tripping of circuits breakers or fuse failure, locate the malfunction and solve it before resetting the circuit breaker or replacing the fuse. If the malfunction is not repairable by consult this manual, contact a technician.
- Keep the operation area of the motorized gate free while the gate is in motion, and do not create strength to the gate movement.
- Do not perform any operation on mechanical elements or hinges if the product is in motion.

RESPONSABILITY

- Supplier disclaims any liability if:
 - Product failure or deformation result from improper installation use or maintenance!
 - Safety norms are not followed in the installation, use and maintenance of the product.
 - Instructions in this manual are not followed.
 - Damaged is caused by unauthorized modifications
 - In these cases, the warranty is voided.

MOTORLINE ELECTROCELOS SA.

Travessa do Sobreiro, nº29
4755-474 Rio Côvo (Santa Eugénia)
Barcelos, Portugal

SYMBOLS LEGEND:



• Important safety notices



• Useful information



• Programming information



• Potentiometer information



• Connectors information



• Buttons information

02. AUTOMATISM

TECHNICAL CHARACTERISTICS

MPIE10 bollards were developed for traffic control, limiting the passage of vehicles. Built entirely in 304 stainless steel and PVC, they are anti-vandalism bollard, suitable for underground installation.

	400	600	800
• Course	370mm	570mm	785mm
• Weight	35Kg	40Kg	45Kg
• Power Supply	24 Vdc		
• Power	150W		
• Nominal power consumption	3A		
• Operating Temperature	-20 ~ +50°C		
• Material of the moving piece	Ø204x2mm Stainless steel		
• Cover	Non-slip 4mm Stainless steel		
• Material of the embedded piece	10mm PVC		
• Top flange	400mm		
• Operation frequency	70%		
• Lifting and Lowering Speed	40-45mm/sec		
• Protection Index	IP55		
• Maximum weight supported	20.000Kg		

MANUAL UNLOCKING

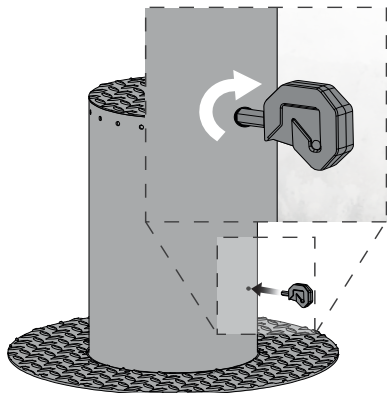

To unlock the electromechanical bollard, insert the key into the slot and turn in a clockwise direction.



- Please hold the key to descend the bollard slowly, because once unlocked, the bollard is free and will go down if you don't hold it.

- The bollard can be equipped with a 24Vdc battery which, in the event of a power failure, allows you to open (down) the bollard once. Do not use the bollard again until power is restored, because the battery was placed only for emergency situations and may not have enough energy to complete the closure.

02. AUTOMATISM

KIT COMPONENTS

The kit is composed by the following components:

- 01 • 01 MSC50 twilight sensor
- 02 • 01 Control board
- 03 • 01 Integrated RGB LED module
- 04 • 01 MPIE10
- 05 • 02 FALK remote controls

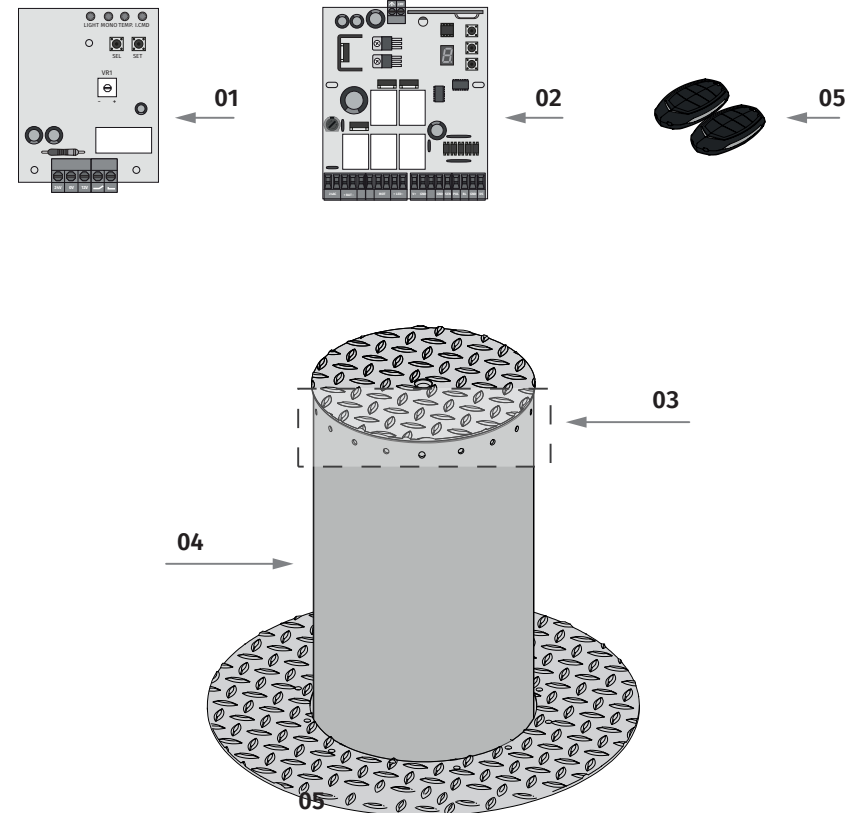

02. AUTOMATISM

DIMENSIONS

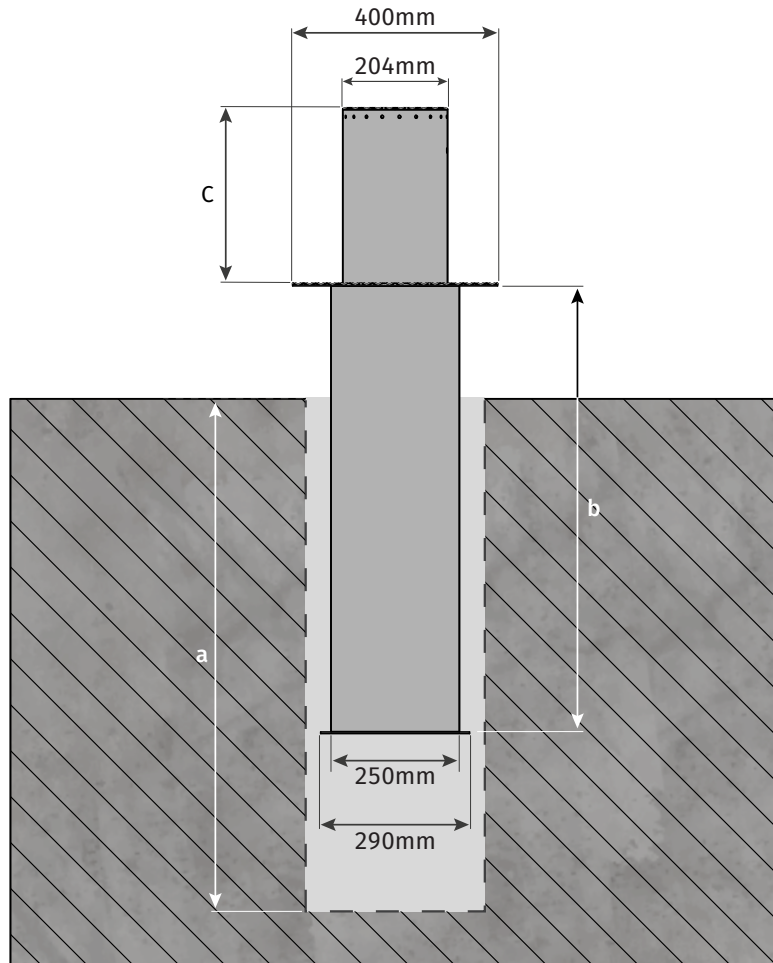

	400	600	800
• Dimension (a)	1040mm	1250mm	1450mm
• Dimension (b)	870mm	1080mm	1280mm
• Dimension (c)	370mm	570mm	785mm

03. INSTALLATION

AUTOMATISM INSTALLATION



Before any installation step, check and make sure that the cable inside the automation is in accordance with **image A**, well-adjusted to the support.

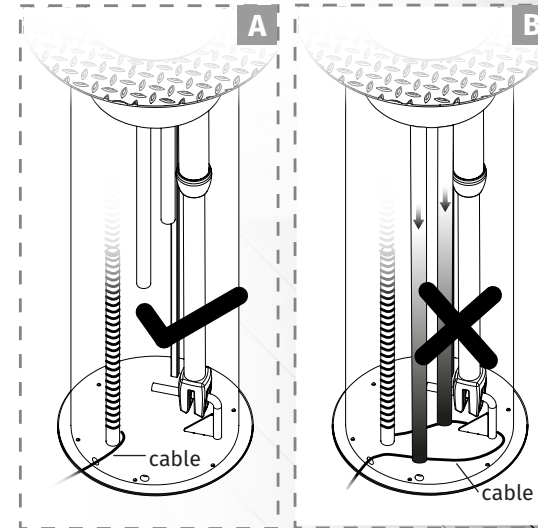

The cable **cannot** have too much slack inside the automation or wrapped around the motor support rod **due to the risk of crushing by the stoppers** as shown in **figure B**.

1 CREATE FOUNDATION

Drill a hole on the ground, with the necessary dimension for the placement of the bollard, taking into account the table on page 5A.

2 APPLY CONCRETE

Apply the concrete at the bottom of the hole.

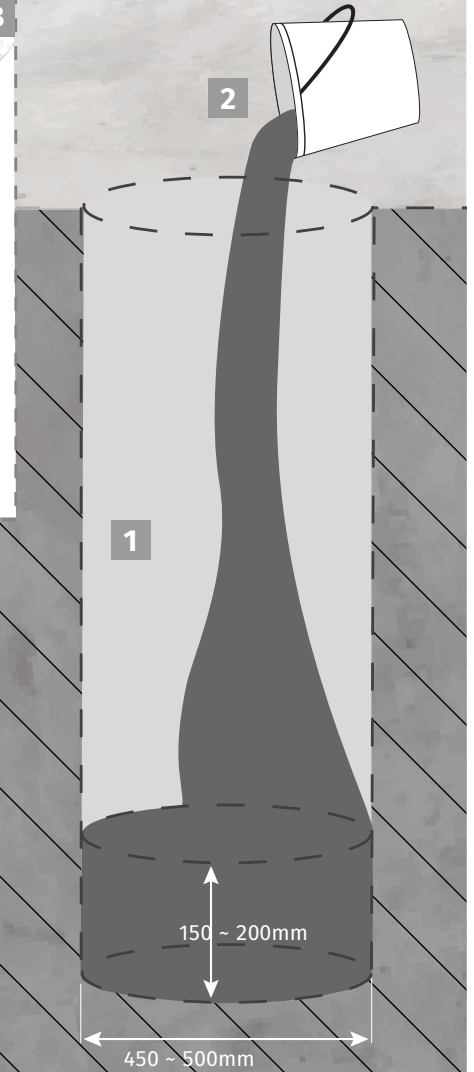

03. INSTALLATION

AUTOMATISM INSTALLATION

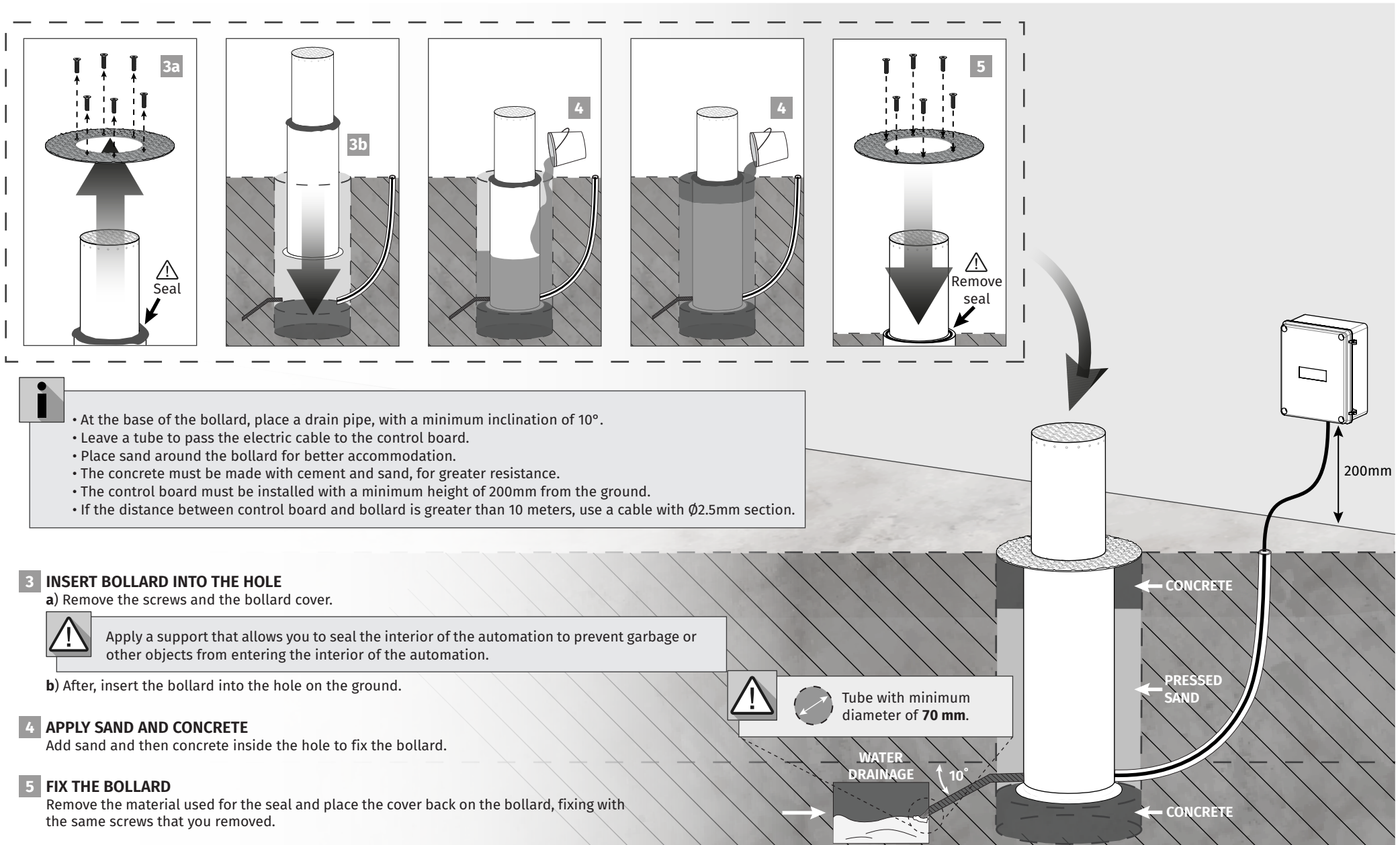

- At the base of the bollard, place a drain pipe, with a minimum inclination of 10°.
- Leave a tube to pass the electric cable to the control board.
- Place sand around the bollard for better accommodation.
- The concrete must be made with cement and sand, for greater resistance.
- The control board must be installed with a minimum height of 200mm from the ground.
- If the distance between control board and bollard is greater than 10 meters, use a cable with $\varnothing 2.5\text{mm}$ section.

3 INSERT BOLLARD INTO THE HOLE

a) Remove the screws and the bollard cover.

Apply a support that allows you to seal the interior of the automation to prevent garbage or other objects from entering the interior of the automation.

b) After, insert the bollard into the hole on the ground.

4 APPLY SAND AND CONCRETE

Add sand and then concrete inside the hole to fix the bollard.

5 FIX THE BOLLARD

Remove the material used for the seal and place the cover back on the bollard, fixing with the same screws that you removed.

Tube with minimum diameter of 70 mm.

WATER DRAINAGE
10°

04. TROUBLESHOOTING

INSTRUCTIONS FOR FINAL CONSUMERS AND SPECIALIZED TECHNICIANS

Anomaly	Procedure	Behavior	Procedure II	Discovering the origin of the problem		
• Bollard doesn't work.	• Check that the control board has power and it is working correctly.	• Still not working.	• Consult a qualified technician.	<p>1 • Open control box and check if it has 230V power supply;</p> <p>2 • Check input fuses of the control board;</p>	<p>3 • Disconnect bollards from control board and test them by connecting directly to power supply.</p>	<p>4 • If the bollard work, the problem is on the control board. Pull it out and send it to our technical services for diagnosis;</p> <p>5 • If the bollard don't work, remove them from installation site and send to our technical services for diagnosis.</p>
• Bollard doesn't move but makes noise.	• Unlock the bollard and move it manually to check if there are mechanical problems.	• The bollard is stuck.	• Consult a technician.	Check all motion systems related with the bollard and to find out what is the problem.		
		• The bollard moves easily.	• Consult a qualified technician.	<p>1 • Disconnect the bollard from control board and test it by connecting directly to power supply in order to find out if it has</p>	<p>problems;</p> <p>2 • If the bollard work, the problem is on the control board.</p>	<p>Pull it out and send it to our technical services for diagnosis;</p> <p>3 • If the bollard don't work, remove</p>
• Bollard opens but doesn't close.	• Unlock the bollard and manually move it to the closed position. Lock the Bollard (s) again. Turn the general electrical board off for 5 seconds, then turn it back on. Give opening order with the remote control.	• Bollard opened but didn't close again.	<p>1 • Check if there are any obstacles obstructing the movement of the bollard.</p> <p>2 • Check if any control devices of the bollard are stuck and sending a permanent signal to the control board.</p> <p>3 • Consult a qualified technician.</p>	<p>All control boards have LEDs that easily allow to conclude which devices are with anomalies. All safety devices LEDs (DS) in normal situations remain On. All "START" circuits LEDs in normal situations remain Off. If LEDs devices are not all On, there is some security systems malfunction (photocells, safety edges). If "START" circuits LEDs are turn (Op and Cl), there is a control device sending permanent signal.</p>	<p>A) SECURITY SYSTEMS:</p> <p>1 • Close with a shunt all safety systems on the control board (check manual of the control board. If the automated system starts working normally check for the problematic device.</p> <p>2 • Remove one shunt at a time until you find the malfunction device.</p> <p>3 • Replace it for a functional device and check if the motor works correctly with all the other devices. If you find another one</p>	<p>defective, follow the same steps until you find all the problems.</p> <p>B) START SYSTEMS:</p> <p>1 • Disconnect all wires connected to the START connector.</p> <p>2 • If the LED turned OFF, try reconnecting one device at a time until you find the defective device.</p> <p>NOTE • In case procedures described in sections A) and B) don't result, remove control board and send to our technical services for diagnosis.</p>
• Bollard doesn't make complete route.	• Unlock the bollard and move it manually to check if there are mechanical problems.	• Encountered problems?	• Consult an experienced bollards expert.	Check all motion systems related with the bollard and to find out what is the problem.		
		• The bollard moves easily?	• Consult a qualified technician.	<p>1 • Disconnect motor from control board and test it by connecting directly to power supply in order to find out if it is broken;</p> <p>2 • If the bollard(s) doesn't work, remove it from installation site and send to our technical services for diagnosis.</p> <p>3 • If motor work well and move</p>	<p>the bollard at full force during the entire course, the problem is with control board. Set force using trimmer on the board. Make a new working time programming, giving enough time for opening and closing with appropriate force (consult control board manual).</p> <p>4 • If this doesn't work, remove control board and send it to</p>	<p>technical services.</p> <p>NOTE • Setting force of the control board should be enough to make the bollard open and close without stopping, but should stop and invert with a little effort from a person. In case of safety systems failure, the gate shall never cause physical damaged to obstacles (vehicles, people, etc.).</p>