

EN

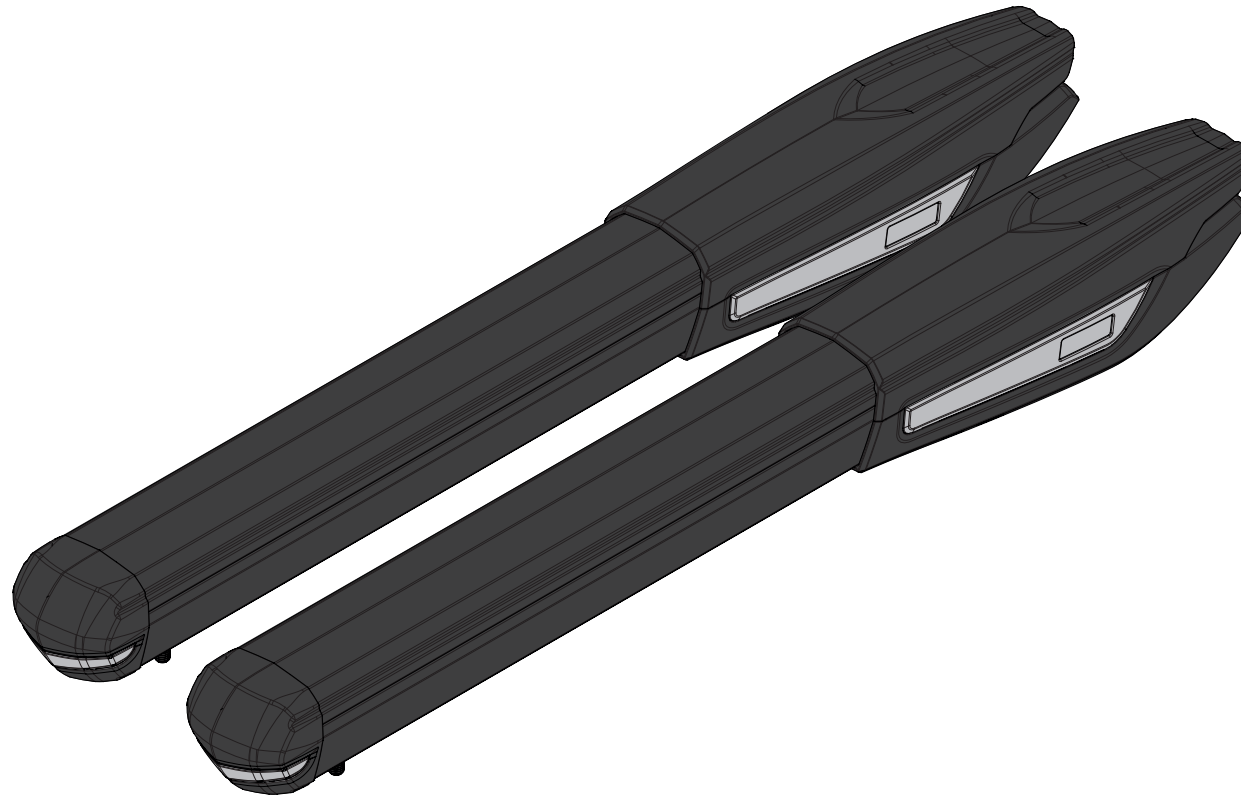

PERSA 400

USER'S AND INSTALLER'S MANUAL



motorline[®]
PROFESSIONAL



V4.3
REV. 05/2024

00. CONTENT

INDEX

01. SAFETY INSTRUCTIONS

ATTENTION _____ 1B

02. PACKAGE

INSIDE PACKAGE _____ 4A

03. AUTOMATISM

TECHNICAL SPECIFICATIONS _____ 4B

LOCK/UNLOCK MOTOR _____ 5A

04. INSTALLATION

VERTICAL INSTALLATION DIMENSIONS _____ 5B

HORIZONTAL INSTALLATION DIMENSIONS _____ 6A

INSTALLATION STEPS _____ 7A

MICROS ADJUSTMENT _____ 8A

INSTALLATION MAP _____ 9

05. CONNECTION SCHEME

110V/230V MOTOR _____ 10A

24V MOTOR _____ 10A

06. COMPONENTS TEST

24V MOTOR _____ 10B

110V/230V MOTOR _____ 11

07. MAINTENANCE







MAINTENANCE _____ 12

08. TROUBLESHOOTING

FINAL CONSUMERS INSTRUCTIONS _____ 13

INSTRUCTIONS FOR SPECIALIZED INSTALLERS _____ 13

01. SAFETY INSTRUCTIONS

| | |
|---|---|
|  | This product is certified in accordance with European Community (EC) safety standards. |
|  | This product complies with Directive 2011/65/EU of the European Parliament and of the Council, of 8 June 2011, on the restriction of the use of certain hazardous substances in electrical and electronic equipment and with Delegated Directive (EU) 2015/863 from Commission. |
|  | (Applicable in countries with recycling systems). This marking on the product or literature indicates that the product and electronic accessories (eg. Charger, USB cable, electronic material, controls, etc.) should not be disposed of as other household waste at the end of its useful life. To avoid possible harm to the environment or human health resulting from the uncontrolled disposal of waste, separate these items from other types of waste and recycle them responsibly to promote the sustainable reuse of material resources. Home users should contact the dealer where they purchased this product or the National Environment Agency for details on where and how they can take these items for environmentally safe recycling. Business users should contact their vendor and check the terms and conditions of the purchase agreement. This product and its electronic accessories should not be mixed with other commercial waste. |
|  | This marking indicates that batteries should not be discarded like other household waste at the end of their useful life. Batteries must be delivered to selective collection points for recycling. |
|  | The different types of packaging (cardboard, plastic, etc.) must be subject to selective collection for recycling. Separate packaging and recycle it responsibly. |
|  | This marking indicates that the product and electronic accessories (eg. charger, USB cable, electronic material, controls, etc.) are susceptible to electric shock by direct or indirect contact with electricity. Be cautious when handling the product and observe all safety procedures in this manual. |

01. SAFETY INSTRUCTIONS

GENERAL WARNINGS

- This manual contains very important safety and usage information. Read all instructions carefully before beginning the installation/usage procedures and keep this manual in a safe place that it can be consulted whenever necessary.
- This product is intended for use only as described in this manual. Any other enforcement or operation that is not mentioned is expressly prohibited, as it may damage the product and put people at risk causing serious injuries.
- This manual is intended firstly for specialized technicians, and does not invalidate the user's responsibility to read the "User Norms" section in order to ensure the correct functioning of the product.
- The installation and repair of this product may be done by qualified and specialized technicians, to assure every procedure are carried out in accordance with applicable rules and norms. Nonprofessional and inexperienced users are expressly prohibited of taking any action, unless explicitly requested by specialized technicians to do so.
- Installations must be frequently inspected for unbalance and the wear signals of the cables, springs, hinges, wheels, supports and other mechanical assembly parts.
- Do not use the product if it is necessary repair or adjustment is required.
- When performing maintenance, cleaning and replacement of parts, the product must be disconnected from power supply. Also including any operation that requires opening the product cover.
- The use, cleaning and maintenance of this product may be carried out by any persons aged eight years old and over and persons whose physical, sensorial or mental capacities are lower, or by persons without any knowledge of the product, provided that these are supervision and instructions given by persons with experienced in terms of usage of the product in a safe manner and who understands the risks and dangers involved.

- Children shouldn't play with the product or opening devices to avoid the motorized door or gate from being triggered involuntarily.
- If the power cable is damaged, it must be replaced by the manufacturer, after-sales service or similarly qualified personnel to avoid danger.
- The device must be disconnected from the electrical network when removing the battery.
- Ensure that blocking is avoided between the actuated part and its fixed parts due to the opening movement of the actuated part.

WARNINGS FOR TECHNICIANS

- Before beginning the installation procedures, make sure that you have all the devices and materials necessary to complete the installation of the product.
- You should note your Protection Index (IP) and operating temperature to ensure that is suitable for the installation site.
- Provide the manual of the product to the user and let them know how to handle it in an emergency.
- If the automatism is installed on a gate with a pedestrian door, a door locking mechanism must be installed while the gate is in motion.
- Do not install the product "upside down" or supported by elements do not support its weight. If necessary, add brackets at strategic points to ensure the safety of the automatism.
- Do not install the product in explosive site.
- Safety devices must protect the possible crushing, cutting, transport and danger areas of the motorized door or gate.
- Verify that the elements to be automated (gates, door, windows, blinds, etc.) are in perfect function, aligned and level. Also verify if the necessary mechanical stops are in the appropriate places.
- The control board must be installed on a safe place of any fluid (rain, moisture, etc.), dust and pests.
- You must route the various electrical cables through protective tubes, to protect them against mechanical exertions, essentially on

01. SAFETY INSTRUCTIONS

the power supply cable. Please note that all the cables must enter the control board from the bottom.

- If the automatism is to be installed at a height of more than 2,5m from the ground or other level of access, the minimum safety and health requirements for the use of work equipment workers at the work of Directive 2009/104/CE of European Parliament and of the Council of 16 September 2009.
- Attach the permanent label for the manual release as close as possible to the release mechanism.
- Disconnect means, such as a switch or circuit breaker on the electrical panel, must be provided on the product's fixed power supply leads in accordance with the installation rules.
- If the product to be installed requires power supply of 230Vac or 110Vac, ensure that connection is to an electrical panel with ground connection.
- The product is only powered by low voltage safety with control board (only at 24V motors).
- Parts/products weighing more than 20 kg must be handled with special care due to the risk of injury. It is recommended to use suitable auxiliary systems for moving or lifting heavy objects.
- Pay special attention to the danger of falling objects or uncontrolled movement of doors/gates during the installation or operation of this product.

WARNINGS FOR USERS

- Keep this manual in a safe place to be consulted whenever necessary.
- If the product has contact with fluids without being prepared, it must immediately disconnect from the power supply to avoid short circuits, and consult a specialized technician.
- Ensure that technician has provided you the product manual and informed you how to handle the product in an emergency.
- If the system requires any repair or modification, unlock the automatism, turn off the power and do not use it until all safety

conditions have been met.

- In the event of tripping of circuits breakers or fuse failure, locate the malfunction and solve it before resetting the circuit breaker or replacing the fuse. If the malfunction is not repairable by consult this manual, contact a technician.
- Keep the operation area of the motorized gate free while the gate in in motion, and do not create strength to the gate movement.
- Do not perform any operation on mechanical elements or hinges if the product is in motion.

RESPONSABILITY

- Supplier disclaims any liability if:
 - Product failure or deformation result from improper installation use or maintenance!
 - Safety norms are not followed in the installation, use and maintenance of the product.
 - Instructions in this manual are not followed.
 - Damaged is caused by unauthorized modifications
 - In these cases, the warranty is voided.

MOTORLINE ELECTROCELOS SA.

Travessa do Sobreiro, nº29
4755-474 Rio Côvo (Santa Eugénia)
Barcelos, Portugal

SYMBOLS LEGEND:



• Important safety notices



• Useful information



• Programming information



• Potentiometer information



• Connectors information



• Buttons information

02. PACKAGE

INSIDE PACKAGE

In the package you will find the following components:

- 01 • 02 Swing motors
- 02 • 01 Control board
- 03 • 02 Remote controls (4 channels)
- 04 • 02 Front supports
- 05 • 02 Rear supports
- 06 • 02 Capacitors [12,5µF (230V) or 35µF (110V)]
- 07 • 01 Pair of photocells
- 08 • 01 User's manual
- 09 • Release keys

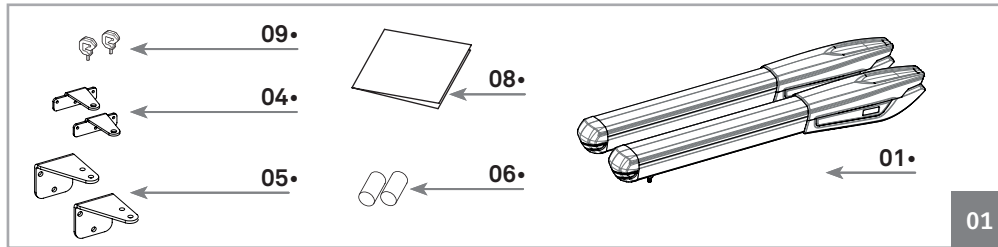

Electronic components in the kit:

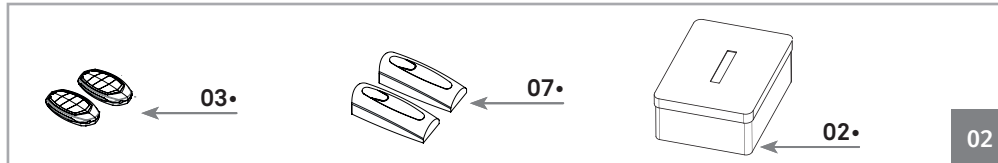

Kit Package:

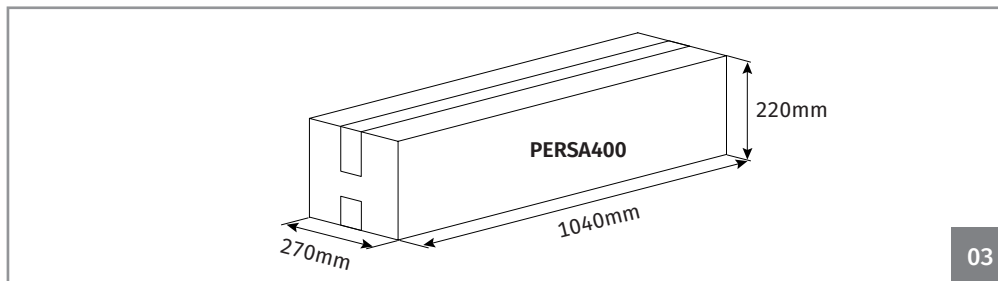

03. AUTOMATISM

TECHNICAL SPECIFICATIONS

PERSA specifications are as follow:

| | | PERSA400 |
|--------------------------|----------|-----------------|
| • Power Supply | 230V | AC 230V 50/60Hz |
| | 110V | AC 110V 50/60Hz |
| | 24V | DC 24V |
| • Power | 230/110V | 300W |
| | 24V | 80W |
| • Current | 230V | 1,3A |
| | 110V | 2,5A |
| | 24V | 3A |
| • Rotational speed | 230/110V | 1400 RPM |
| | 24V | 1650 RPM |
| • Noise level | | <50dB |
| • Force | | 2800N |
| • Operating temperatures | | -25°C to 65°C |
| • Thermal protection | | 120°C |
| • Protection class | | IP54 |
| • Working frequency | 230/110V | 25% |
| | 24V | Intensive |
| • Course | | 400mm |
| • Max leaf length | | <3000mm |
| • Capacitor | 230V | 12,5µF |
| | 110V | 35µF |
| • Opening speed | 230V | 20mm/s |
| | 24V | 23,5mm/s |

03. AUTOMATISM

TECHNICAL SPECIFICATIONS

PERSA 400 dimensions are the following:

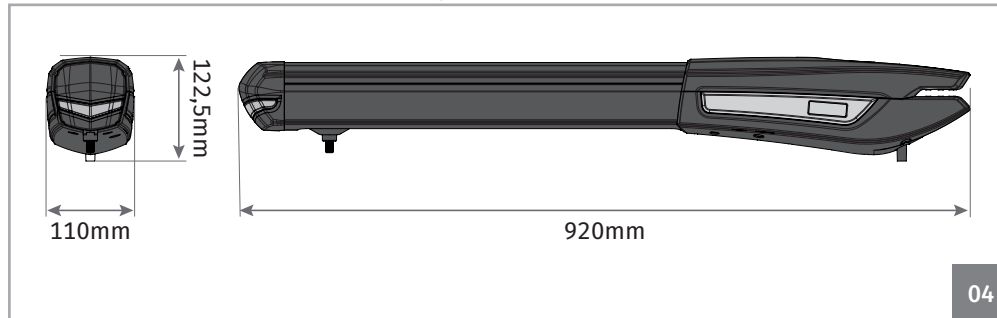

LOCK/UNLOCK MOTOR

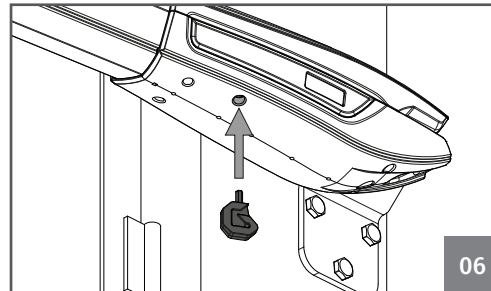
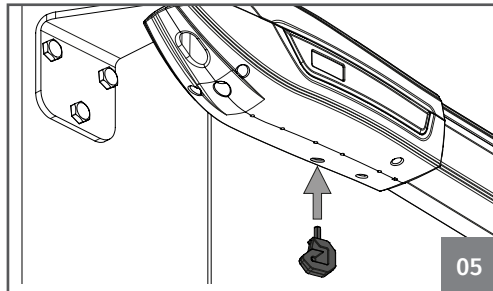

Place the unlocking key in the slot signed on image 05 (motor installed on the left) or 06 (motor installed on the right).

Turn the key to lock or unlock the motor.

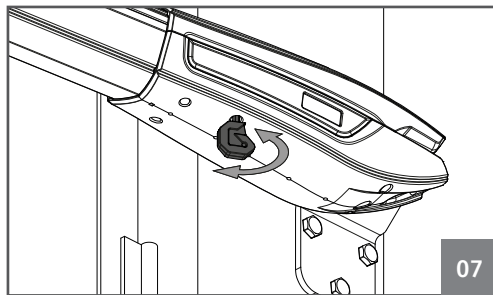

04. INSTALLATION

VERTICAL INSTALLATION DIMENSIONS

PERSA 400 automatism must be installed with a small inclination, to prevent water infiltration through the extension arm.

For this, the front support must be fixed to the gate with a height lower than the height of the rear support. See example below:

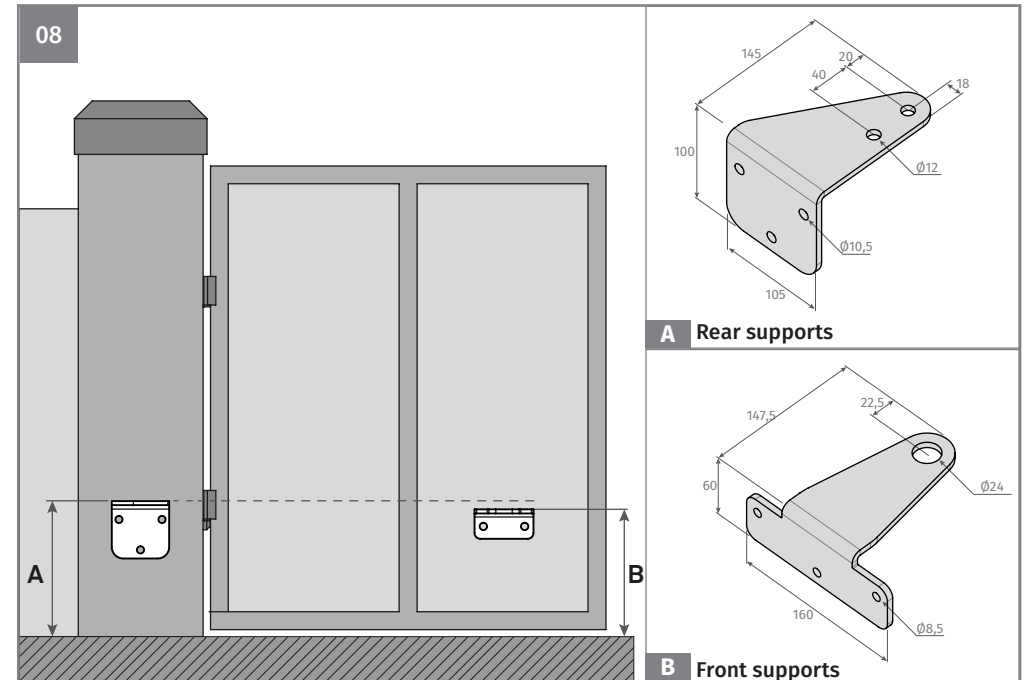

Dimension A • Vertical distance from the floor to the top of the rear support.

Dimension B • Vertical distance from the floor to the top of the front support.

| | | |
|---|----------|--|
| A | ?? mm | • Set dimension A (this can be any size of your choice). |
| B | A - 56mm | • After you set dimension A , subtract 56mm to find dimension B . |

Example:

- If the height of the rear support (dimension A) is set at 600 mm, then the height of the front support (dimension B) will be 544 mm (600mm-56mm).



It is very important that these dimensions are respected! Only this way can be assured the correct functioning and durability of the automatism!
It is also very important that the floor is level to use these dimensions!

04. INSTALLATION

HORIZONTAL INSTALLATION DIMENSIONS

On the illustrated diagrams below and on the next page, the dimensions are defined to be used in the automation installation.

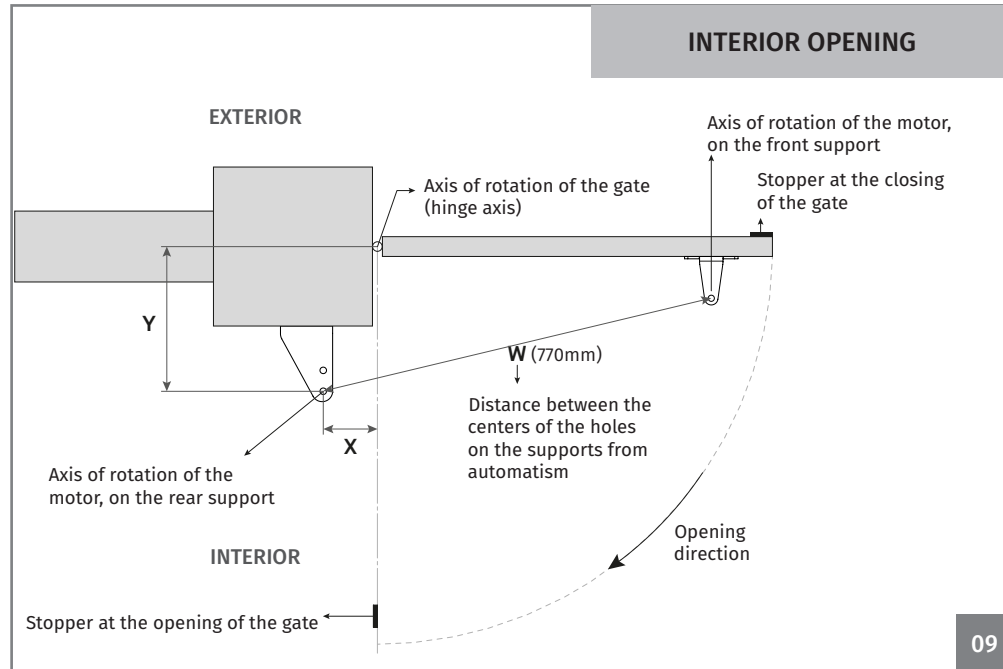

09

* The installation of opening stopper is not mandatory.

During the installation process, it is required to respect the dimensions that are within the highlighted area: (ex: y=170; x=140)

Legend:

Dimension X - Horizontal distance between hinge axis of the gate and the rear axis of rotation of the motor.
Dimension Y - Vertical distance between hinge axis of the gate and the rear axis of rotation of the motor.
Dimension W - Distance between axis of the motor supports (770mm).

| | | PERSA 400 | | | | |
|-------------|-------------|-----------|-------|-------|-----|--|
| Dimension Y | Dimension X | | | | | |
| | 165 | 170 | 175 | 180 | 185 | |
| 195 | - | - | - | - | - | |
| 200 | - | 90,1 | 91,76 | 93,38 | - | |
| 205 | - | 90,24 | 91,86 | - | - | |
| 210 | - | 90,38 | 91,95 | - | - | |
| 215 | - | 90,5 | - | - | - | |
| 220 | - | - | - | - | - | |

X and Y in (mm)

04. INSTALLATION

HORIZONTAL INSTALLATION DIMENSIONS

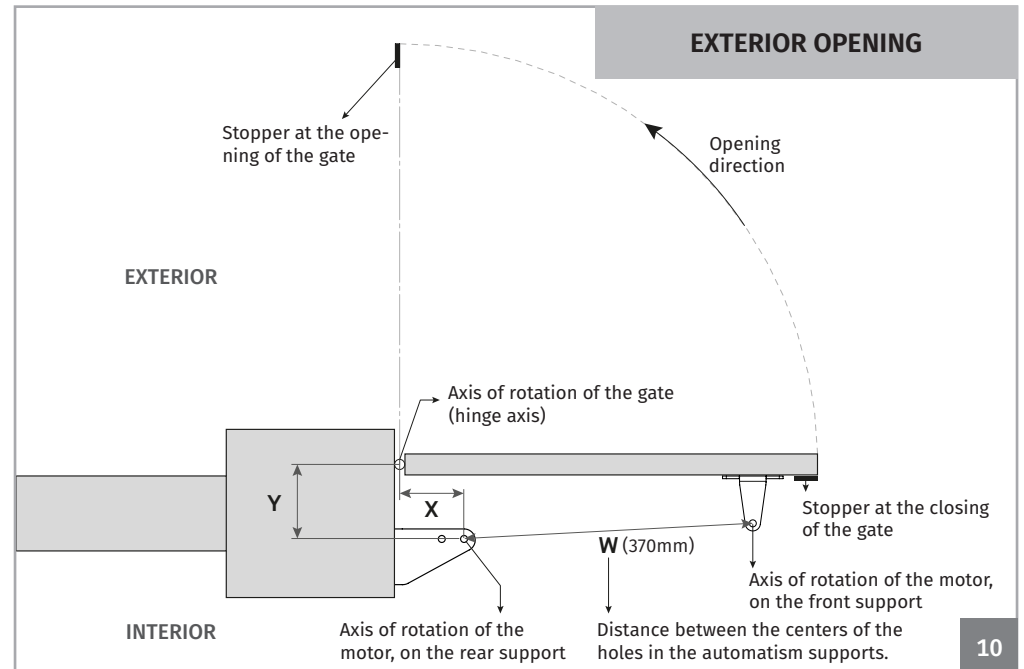

10

* The installation of opening stopper is not mandatory.

During the installation process, it is required to respect the dimensions that are within the highlighted area: (ex: y=190; x=180)

Legend:

Dimension X - Horizontal distance between hinge axis of the gate and the rear axis of rotation of the motor.
Dimension Y - Vertical distance between hinge axis of the gate and the rear axis of rotation of the motor.
Dimension W - Distance between axis of the motor supports (770mm).

| | | PERSA 400 | | | | |
|-------------|-------------|-----------|-------|-----|-----|--|
| Dimension Y | Dimension X | | | | | |
| | 195 | 200 | 205 | 210 | 215 | |
| 160 | - | - | - | - | - | |
| 165 | - | 90,28 | 91,68 | - | - | |
| 170 | - | - | - | - | - | |
| 175 | - | - | - | - | - | |
| 180 | - | - | - | - | - | |

X and Y in (mm)

04. INSTALLATION

INSTALLATION STEPS

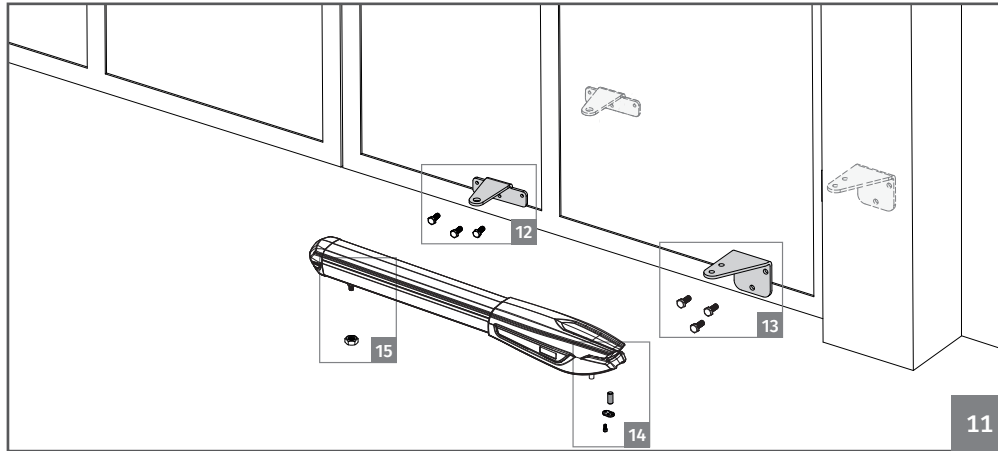

Pay attention to the installation dimensions mentioned on pages 5B, 6A and 6B!

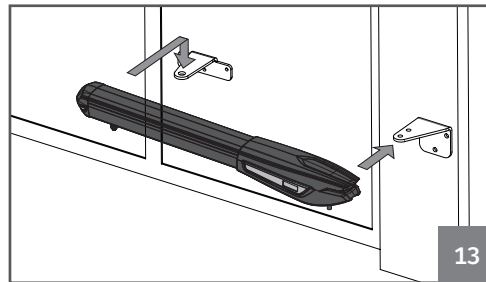
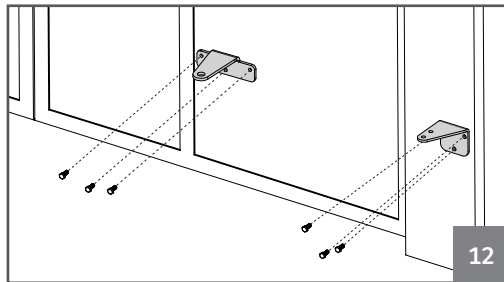

01 • Fix the supports.

- The rear support must be fixed to the pillar or wall, respecting the dimensions provided on the previous pages.
- The front support must be fixed to the gate, respecting the height and distance dimensions for the rear support. These can be fixed using screws with mechanical/chemical bushing, welding, or any other method of your choice as long as you ensure proper fixing of the supports!

02 • Install the automatism on the supports.

- The motor must be placed on both supports the same time to avoid leaving the motor suspended by only one of the supports. To make the task easier, you should unlock the gate in order to be able to extend/retract arm easily (see page 5B), to get the correct position for supports.

04. INSTALLATION

INSTALLATION STEPS

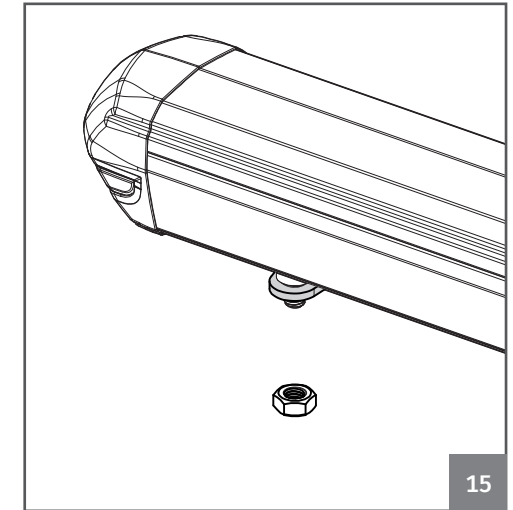
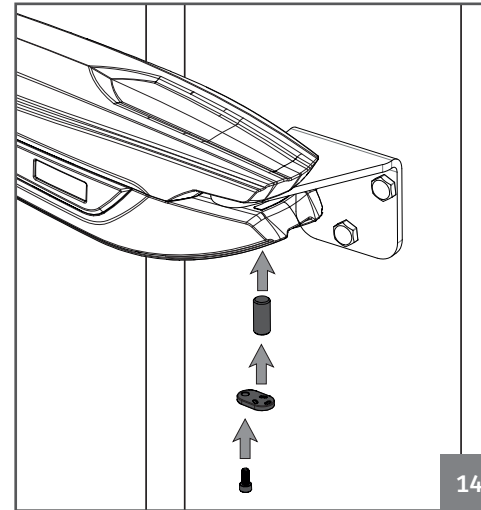

03 • Test the movement.

- Place the dowels in each support with a small amount of lubricant so that there is no excessive friction.
- With the motor unlocked, move the gate by hand to check that the gate opens and closes without any hindrance. This will ensure that the automatism is not subject to problems during its operation.

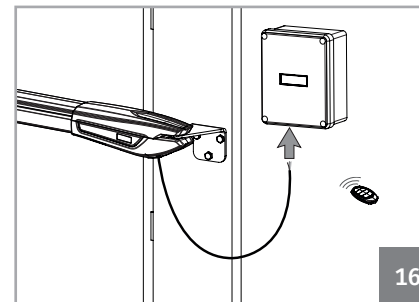

04 • Connect the automatism to the control board and configure the control devices.

- With the automatism already installed, connect it to the control board for programming (see manual for the control board to be configured). You must also configure the desired control devices (remote controls, pushbuttons, etc.) and other additional components such as antenna, flashing lamp, key selector, among others.



It is important to respect this installation order!

Otherwise, it is not possible to ensure correct installation and the motors may not work properly!

04. INSTALLATION

MICROS ADJUSTMENT

01 • Unlock the motor (see page 5A).

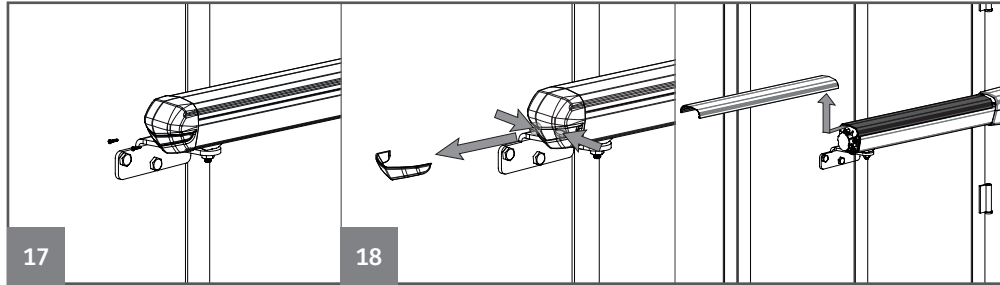

02 • Remove the chrome clip with a screwdriver.

03 • Unfasten the two front screws, remove the cover and the profile cover.

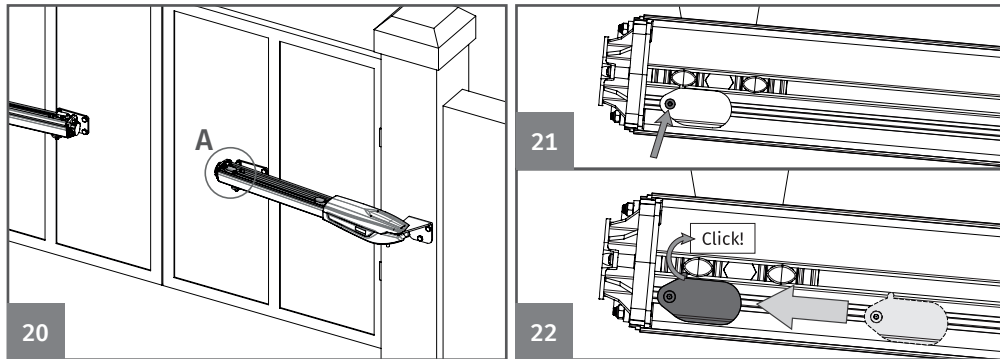
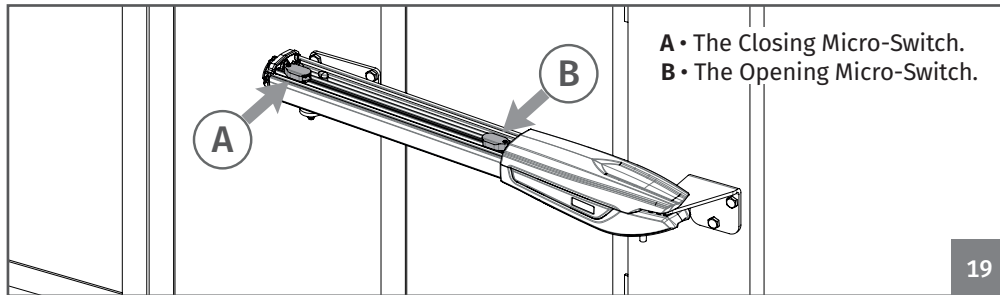

03 • Take the gate to the closed position.

04 • Loosen the screw shown in the image (21), so that it is possible to move the micro-switch in the profile.

05 • Adjust the closure micro-switch (A) until it makes *click* on the pressure piece. Tighten the screw to secure the micro in that position.

04. INSTALLATION

MICROS ADJUSTMENT

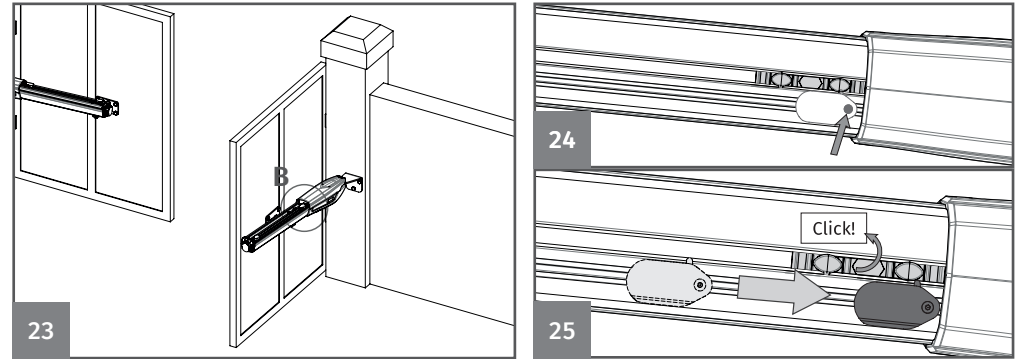

06 • Take the gate to the open position.

07 • Loosen the screw shown in the image (24), so that it is possible to move the micro-switch in the profile.

08 • Adjust the closure micro-switch (B) until it makes *click* on the pressure piece. Tighten the screw to secure the micro in that position.

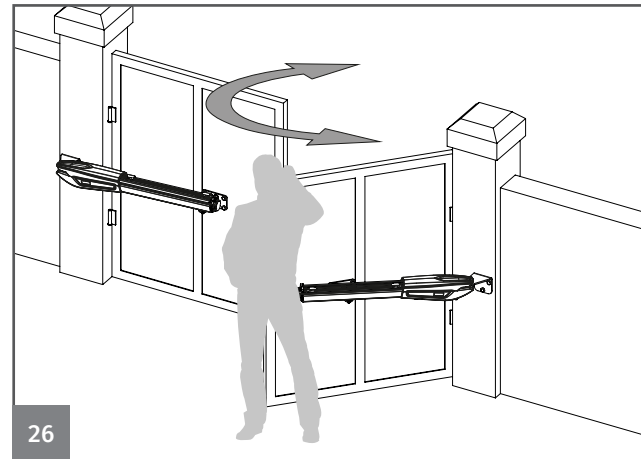

09 • Test the gate manually and if necessary readjust the micros, as indicated in the previous paragraphs.

10 • When finished, place the profile cover and the plastic cover.

11 • Repeat the whole process for the other motor.

04. INSTALLATION

INSTALLATION MAP

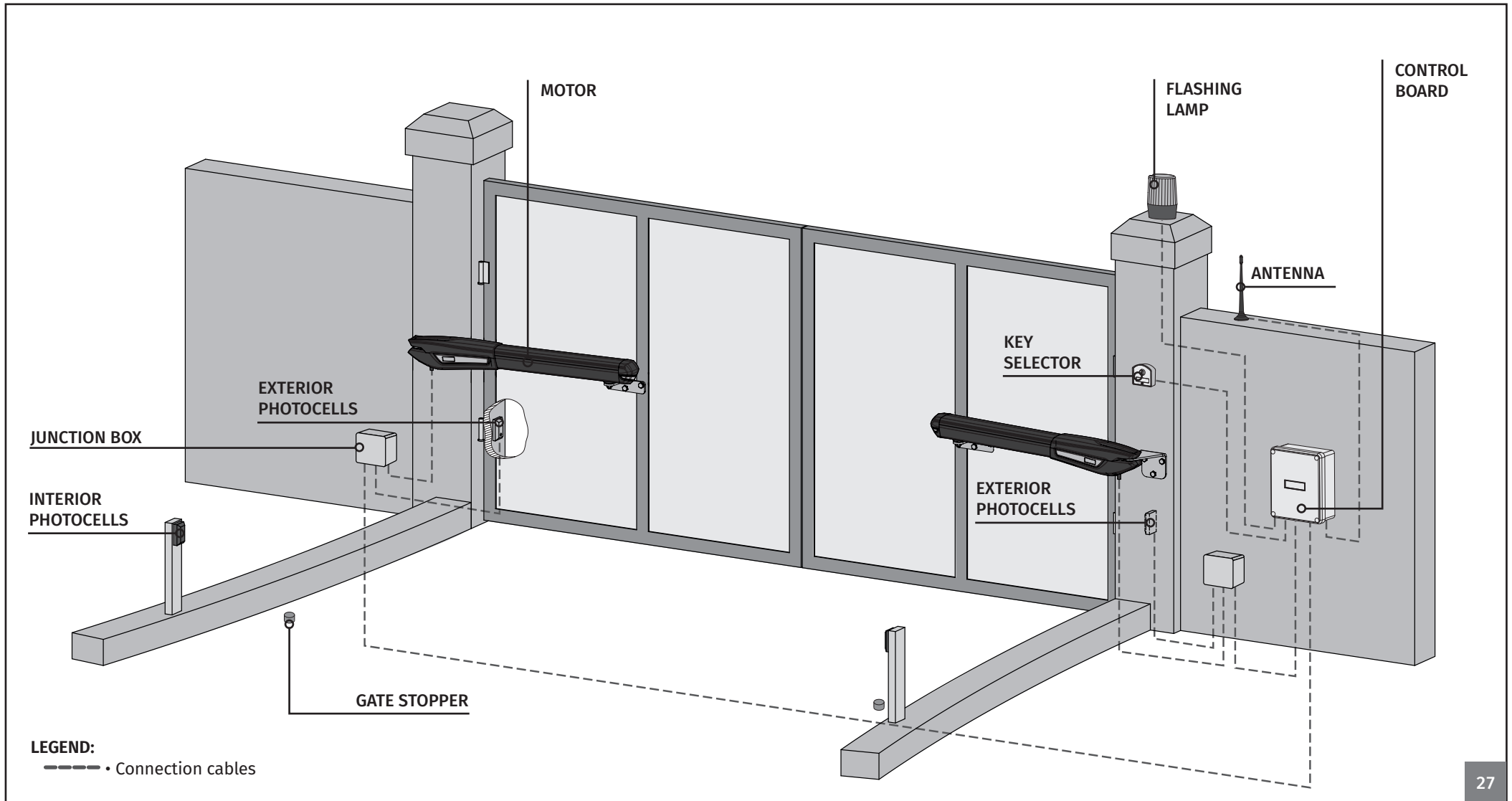

27



It is important to use stoppers at the opening and closing of the gate. If not respected, components of the automation may suffer efforts for which they were not prepared, and as a result will be damaged.



It is important to use junction boxes for connections between motors, components and control board. All cables must enter and exit on the bottom of the junction and control board boxes.

05. CONNECTION SCHEME

110V/230V MOTOR

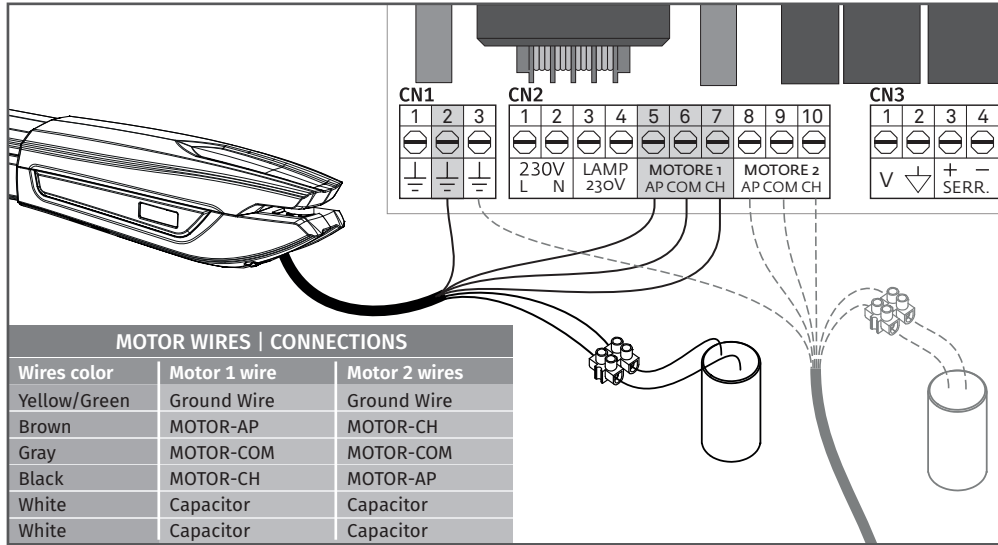

Connections should be made as shown above, connecting the 6 motor wires to the appropriate inputs of the control board and capacitor.

NOTE: The white motor wires are connected directly to the capacitor wires!

24V MOTOR

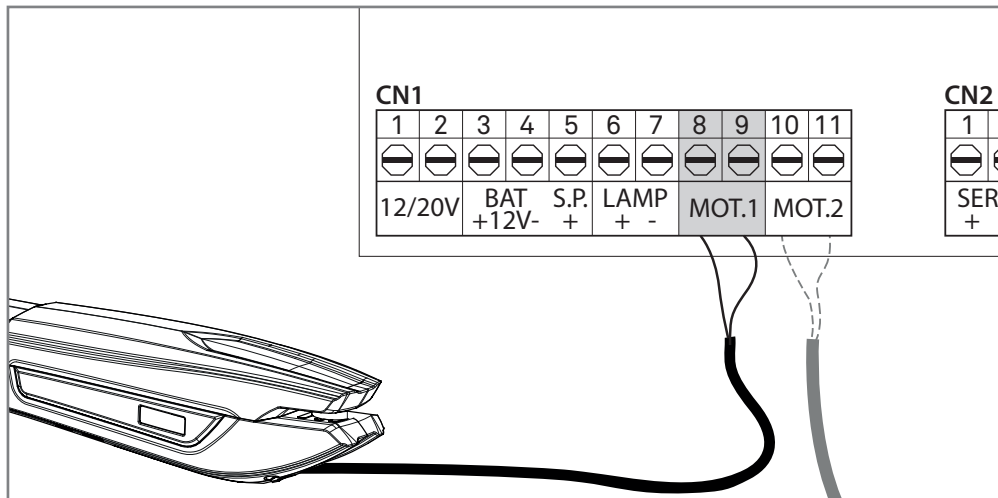

06. COMPONENTS TEST

MOTOR 24V

To detect which are the components with problems in a 24V PERSA automatism installation, it is necessary to conduct tests with a direct connection to a external power supply (battery 24V). In the diagram below shows how to make this connection.

NOTES:

- Once you connect the wires to a 24V battery, the motor must work for one direction. To test the reverse movement, change the position of the wires connected to the battery.

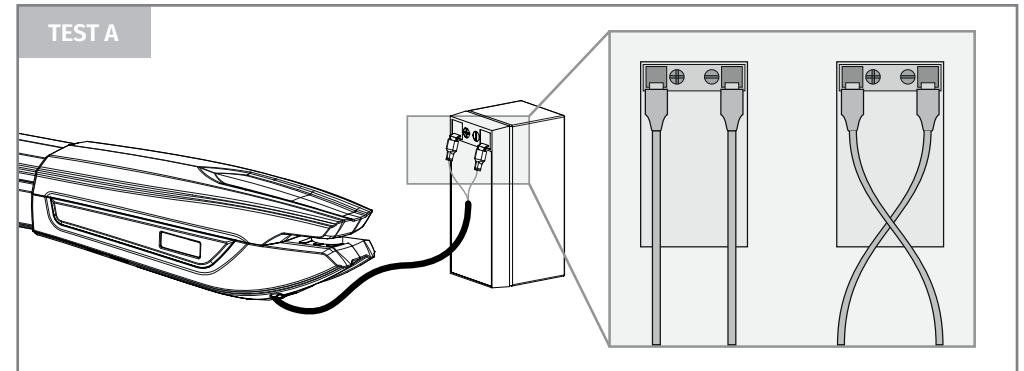

Test A • Make the connections as indicated in the image.

If the motor works, the problem is in the control board. If it does not operate, do the test B.

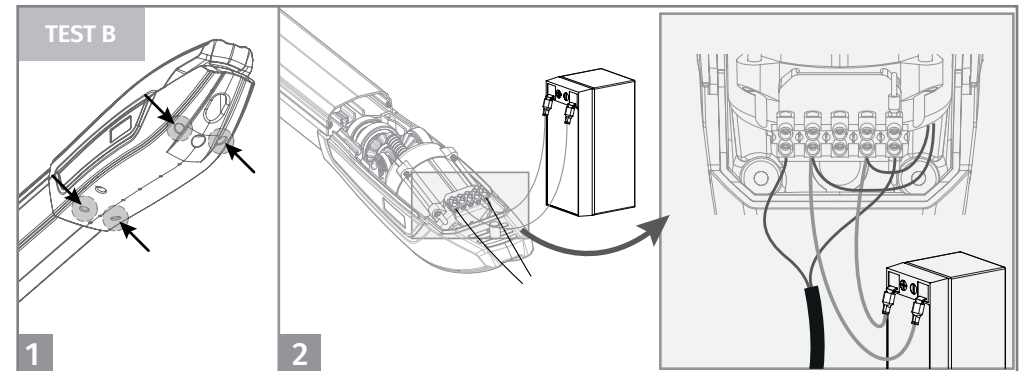

Test B • Loosen the 4 screws to remove the cover and access the internal connections.

Make the connections as indicated in the image.

If the motor works, the problem is on the diode(s) or on the micro(s). If it does not operate, replace with a new 24V motor and re-test to ensure that all is ok.

06. COMPONENTS TEST

110V /230V MOTOR

To detect if the malfunction is on the control board or on the motor is, sometimes, necessary to perform tests with direct connection to a 110V/230V power supply.

For this, it is necessary to intercalate a capacitor on the connection in order to the automatism to work (check the type of capacitor to be used in the product manual).

The diagram below, shows how to make that connection and how to intercalate the different components wires.



All tests must be performed by specialized technicians due to serious danger associated with the bad use of electrical systems!!

NOTES:

- To perform the tests, there is no need to remove the automatism from the place it is installed, because in this way, it is possible to understand if the automatism can function properly connected directly to the power.
- You should use a new capacitor during this test to ensure that the problem is not with the capacitor.

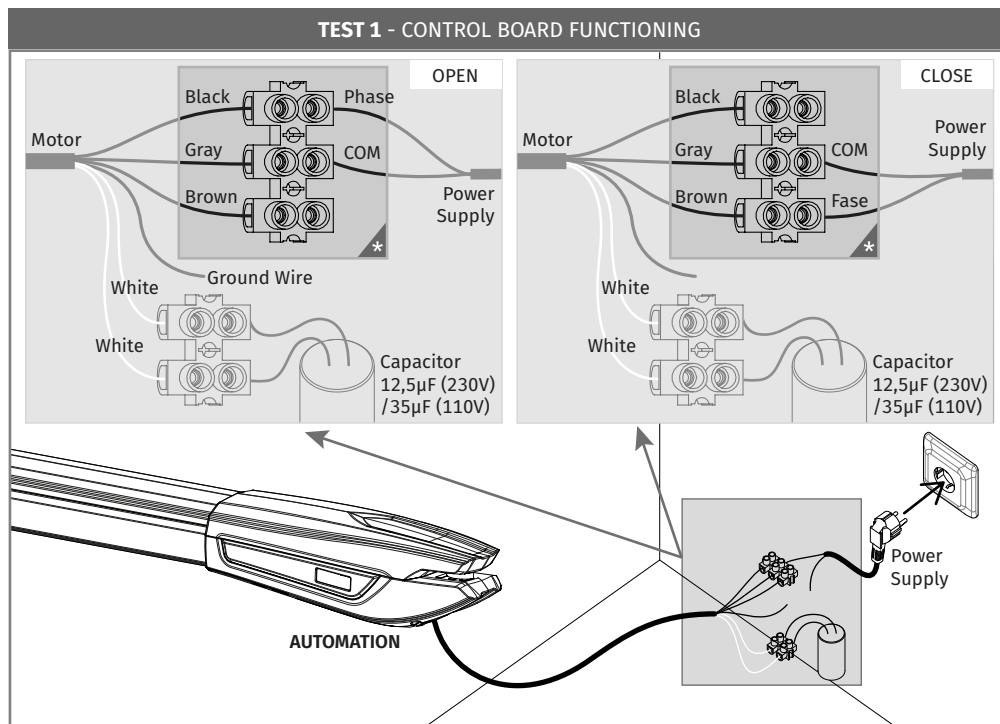

- 01 • Connect the 3 automation wires in the terminal.
 - 02 • Connect the two automation white wires with the capacitor wires.
 - 03 • Connect the power supply wires in the terminal, in the opening the motor will rotate one way and during the closing, the motor will rotate the opposite way.
 - 04 • Finally, connect it to a 230V or 110V power plug, depending on the motor/control board in test. **If the motor works**, the problem is in the control board.
- If the motor does not**, make the **TEST 2**.

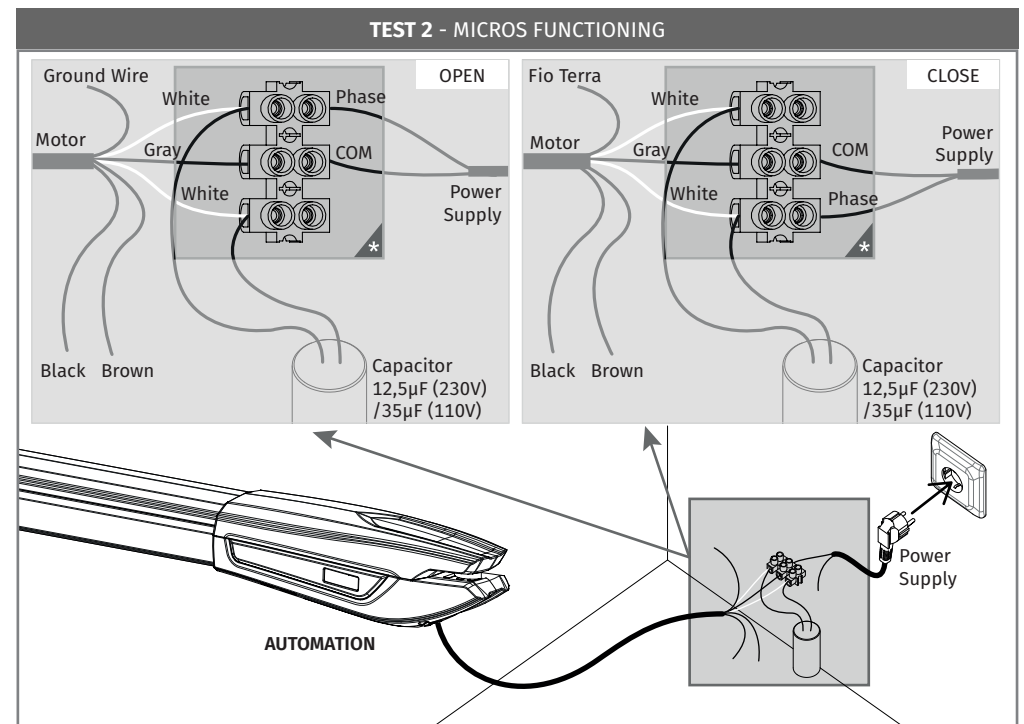

- 01 • Replace the brown and black wires by white wires and connect in the terminal.
 - 02 • Connect the capacitor in the terminal, in the same white wires inputs.
 - 03 • Connect the power supply wires in the terminal, in the opening the motor will rotate one way and during the closing, the motor will rotate the opposite way.
 - 04 • Finally, connect it to a 230V or 110V power plug, depending on the motor/control board in test. **If the motor works**, the problem is in the micrositches.
- If the motor does not work**, normally the problem is on the motor. Replace it with a new one and test again.

07. MAINTENANCE

MAINTENANCE

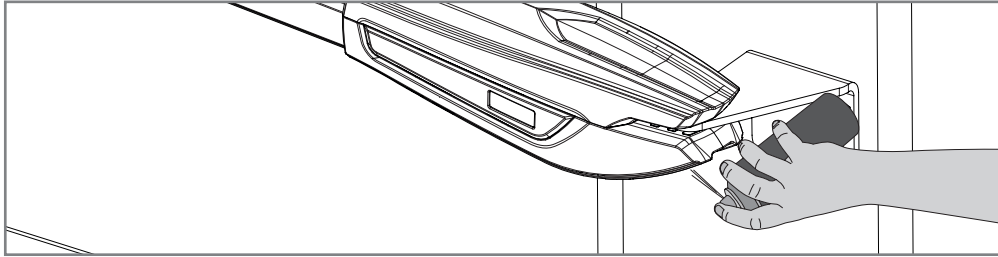

- **Lubricate dowels**
- Place a small amount of lubricant on the holes that contains support dowels.

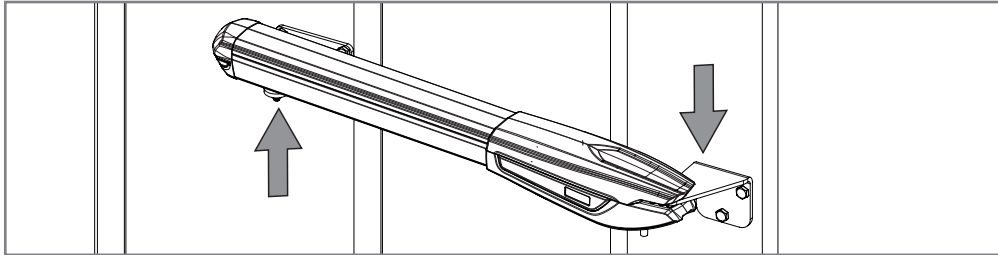

- **Check motor supports**
- Make sure that supports remain well fixed on the pillars and gate to ensure proper functioning of the equipment.



These maintenance measures must be applied every year in order to insure proper functioning of the automatism.

08. TROUBLESHOOTING

FINAL CONSUMERS INSTRUCTIONS

INSTRUCTIONS FOR SPECIALIZED INSTALLERS

| Anomaly | Procedure | Behavior | Procedure II | Discovering the origin of the problem | | | |
|---------------------------------------|--|---------------------------------------|---|--|---|--|--|
| • Motor doesn't work. | • Make sure you have power in the automation control board and if it is working properly. | • Still not working. | • Consult a qualified MOTORLINE technician. | 1 • Open control board and check if it has 230V/110V/24V power supply; 2 • Check input fuses; 3 • Disconnect motors from | control board and test them by connecting directly to power supply in order to find out if they have problems. 4 • If the motors work, the | problem is on the control board. Pull it out and send it to our MOTORLINE technical services for diagnosis; | 5 • If the motors doesn't work, remove them from installation site and send to our MOTORLINE technical services for diagnosis. |
| • Motor doesn't move but makes noise. | • Unlock motor and move gate by hand to check for mechanical problems on the gate. | • Is the gate stuck? | • Consult an experienced gate expert. | 1 • Check all motion axis and associated motion systems related with gate and automatism (dowels, hinges, etc.) to find out what is the problem. | | | |
| | | • Gate moves easily? | • Consult a qualified MOTORLINE technician. | 1 • Check capacitors, testing automatism with new capacitors; 2 • If capacitors are not the problem, disconnect motors from | control board and test them by connecting directly to power supply in order to find out if they have problems. | 3 • If the motors work, the problem is in the control board. Pull it out and send it to our MOTORLINE technical services for diagnosis; | 4 • If the motors doesn't work, remove them from installation site and send to our MOTORLINE technical services for diagnosis. |
| • Motor opens but doesn't close. | • Unlock motor and move gate by hand to closed position. Lock motor(s) again and turn off power supply for 5 seconds. Reconnect it and send order to open gate using remote control. | • Gate opened but didn't close again. | 1 • Check if there is any obstacle in front of the photocells; 2 • Check if any of the control devices (key selector, push button, video intercom, etc.) of the gate are stuck and sending permanent signal to control board; 3 • Consult a qualified MOTORLINE technician. | All MOTORLINE control boards have LEDs that easily allow to conclude which devices are with anomalies. All safety devices LEDs (DS) in normal situations remain On. All "START" circuits LEDs in normal situations remain Off. If LEDs devices are not all On, there is some security systems malfunction (photocells, safety edges), etc. If "START" circuits LEDs are turn On, there is a control device sending permanent signal. | A) SECURITY SYSTEMS: 1 • Close with a shunt all safety systems on the control board (check manual of the control board). If the automated system starts working normally check which device is problematic. 2 • Remove one shunt at a time until you find the malfunction device. 3 • Replace it for a functional device and check if the motor works correctly with all the other devices. If you find another one defective, follow the same steps until you find all the problems. | B) START SYSTEMS: 1 • Disconnect all wires connected to the START connector. 2 • If the LED turned Off, try reconnecting one device at a time until you find the defective device. NOTE: In case procedures described in sections A) and B) don't result, remove control board and send to our technical services for diagnosis. | |
| • Motor doesn't make complete route. | • Unlock motor and move gate by hand to check for mechanical problems on the gate. | • Encountered problems? | • Consult an experienced gate expert. | 1 • Check all motion axis and associated motion systems related with gate and automation (dowels, hinges, etc.) to find out what is the problem. | | | |
| | | • Gate moves easily? | • Consult a qualified MOTORLINE technician. | 1 • Check capacitors, testing with new capacitors; 2 • If capacitors are not the problem, disconnect motors from control board and test them by connecting directly to power supply in order to find out if they are faulty; 3 • If the motors doesn't work, remove them from installation | site and send to our MOTORLINE technical services for diagnosis. 4 • If motors work well and move gate at full force during the entire course, the problem is in the control board. Set force using trimmer on the control board. Make a new working time programming, giving enough time for opening and closing with appropriate force (see manual of | the control board). 5 • If this doesn't work, remove control board and send it to MOTORLINE technical services. NOTE: Setting force of the control board should be enough open and close the gate without stopping, but should stop with a little effort from a person. In case of safety systems failure, | the gate can never cause physical damage to obstacles (vehicles, people, etc.). |