



MTT06

USER'S AND INSTALLER'S MANUAL



motorline[®]
PROFESSIONAL





00. CONTENT

ÍNDEX

01. SAFETY INSTRUCTIONS	1B
02. AUTOMATION	
MTT03	4A
PACKING	4A
TECHNICAL CHARACTERISTICS	4B
DIMENSIONS	4B
03. INSTALLATION	
PRE-INSTALLATION	5A
GROUND PREPARATION	5A
INSTALLATION	5B
04. CONNECTIONS	
DIAGRAM	6
05. PROGRAMMING	
NAVIGATION IN THE MENUS	7A
FUNCTIONS	7A
06. MAINTENANCE	
MAINTENANCE	7B
07. TROUBLESHOOTING	
INSTRUCTIONS FOR FINAL CONSUMERS / SPECIALIZED TECHNICIANS	8

01. SAFETY INSTRUCTIONS

ATTENTION:

	This product is certified in accordance with European Community (EC) safety standards.
	This product complies with Directive 2011/65/EU of the European Parliament and of the Council, of 8 June 2011, on the restriction of the use of certain hazardous substances in electrical and electronic equipment and with Delegated Directive (EU) 2015/863 from Commission.
	(Applicable in countries with recycling systems). This marking on the product or literature indicates that the product and electronic accessories (eg. Charger, USB cable, electronic material, controls, etc.) should not be disposed of as other household waste at the end of its useful life. To avoid possible harm to the environment or human health resulting from the uncontrolled disposal of waste, separate these items from other types of waste and recycle them responsibly to promote the sustainable reuse of material resources. Home users should contact the dealer where they purchased this product or the National Environment Agency for details on where and how they can take these items for environmentally safe recycling. Business users should contact their vendor and check the terms and conditions of the purchase agreement. This product and its electronic accessories should not be mixed with other commercial waste.
	
	This marking indicates that the product and electronic accessories (eg. charger, USB cable, electronic material, controls, etc.) are susceptible to electric shock by direct or indirect contact with electricity. Be cautious when handling the product and observe all safety procedures in this manual.

01. SAFETY INSTRUCTIONS

GENERAL WARNINGS

- This manual contains very important safety and usage information. very important. Read all instructions carefully before beginning the installation/usage procedures and keep this manual in a safe place that it can be consulted whenever necessary.
- This product is intended for use only as described in this manual. Any other enforcement or operation that is not mentioned is expressly prohibited, as it may damage the product and put people at risk causing serious injuries.
- This manual is intended firstly for specialized technicians, and does not invalidate the user's responsibility to read the "User Norms" section in order to ensure the correct functioning of the product.
- The installation and repair of this product may be done by qualified and specialized technicians, to assure every procedure are carried out in accordance with applicable rules and norms. Nonprofessional and inexperienced users are expressly prohibited of taking any action, unless explicitly requested by specialized technicians to do so.
- Installations must be frequently inspected for unbalance and the wear signals of the cables, springs, hinges, wheels, supports and other mechanical assembly parts.
- Do not use the product if it is necessary repair or adjustment is required.
- When performing maintenance, cleaning and replacement of parts, the product must be disconnected from power supply. Also including any operation that requires opening the product cover.
- The use, cleaning and maintenance of this product may be carried out by any persons aged eight years old and over and persons whose physical, sensorial or mental capacities are lower, or by persons without any knowledge of the product, provided that these are supervision and instructions given by persons with experienced in terms of usage of the product in a safe manner and who understands

the risks and dangers involved.

- Children shouldn't play with the product or opening devices to avoid the motorized door or gate from being triggered involuntarily.

WARNINGS FOR TECHNICIANS

- Before beginning the installation procedures, make sure that you have all the devices and materials necessary to complete the installation of the product.
- You should note your Protection Index (IP) and operating temperature to ensure that is suitable for the installation site.
- Provide the manual of the product to the user and let them know how to handle it in an emergency.
- If the automatism is installed on a gate with a pedestrian door, a door locking mechanism must be installed while the gate is in motion.
- Do not install the product "upside down" or supported by elements do not support its weight. If necessary, add brackets at strategic points to ensure the safety of the automatism.
- Do not install the product in explosive site.
- Safety devices must protect the possible crushing, cutting, transport and danger areas of the motorized door or gate.
- Verify that the elements to be automated (gates, door, windows, blinds, etc.) are in perfect function, aligned and level. Also verify if the necessary mechanical stops are in the appropriate places.
- The central must be installed on a safe place of any fluid (rain, moisture, etc.), dust and pests.
- You must route the various electrical cables through protective tubes, to protect them against mechanical exertions, essentially on the power supply cable. Please note that all the cables must enter the central from the bottom.
- If the automatism is to be installed at a height of more than 2,5m from the ground or other level of access, the minimum safety and

01. SAFETY INSTRUCTIONS

health requirements for the use of work equipment workers at the work of Directive 2009/104/CE of European Parliament and of the Council of 16 September 2009.

- Attach the permanent label for the manual release as close as possible to the release mechanism.
- Disconnect means, such as a switch or circuit breaker on the electrical panel, must be provided on the product's fixed power supply leads in accordance with the installation rules.
- If the product to be installed requires power supply of 230Vac or 110Vac, ensure that connection is to an electrical panel with ground connection.
- The product is only powered by low voltage safety with central (only at 24V motors)

WARNINGS FOR USERS

- Keep this manual in a safe place to be consulted whenever necessary.
- If the product has contact with fluids without being prepared, it must immediately disconnect from the power supply to avoid short circuits, and consult a specialized technician.
- Ensure that technician has provided you the product manual and informed you how to handle the product in an emergency.
- If the system requires any repair or modification, unlock the automatism, turn off the power and do not use it until all safety conditions have been met.
- In the event of tripping of circuits breakers or fuse failure, locate the malfunction and solve it before resetting the circuit breaker or replacing the fuse. If the malfunction is not repairable by consult this manual, contact a technician.
- Keep the operation area of the motorized gate free while the gate is in motion, and do not create strength to the gate movement.
- Do not perform any operation on mechanical elements or hinges if the product is in motion.

RESPONSABILITY

- Supplier disclaims any liability if:
 - Product failure or deformation result from improper installation use or maintenance!
 - Safety norms are not followed in the installation, use and maintenance of the product.
 - Instructions in this manual are not followed.
 - Damaged is caused by unauthorized modifications
- In these cases, the warranty is voided.

SYMBOLS LEGEND:



• Important safety notices



• Useful information



• Programming information



• Potentiometer information



• Connectors information



• Buttons information

02. AUTOMATION

MTT06



MTT06 is a tripod turnstile with smooth, quiet operation and low energy consumption. It includes RGB light for indicating the passage and has the possibility of placing sensors on both sides of the device, so that access can be carried out in both directions.

PACKING

Inside the package you will find the following components:

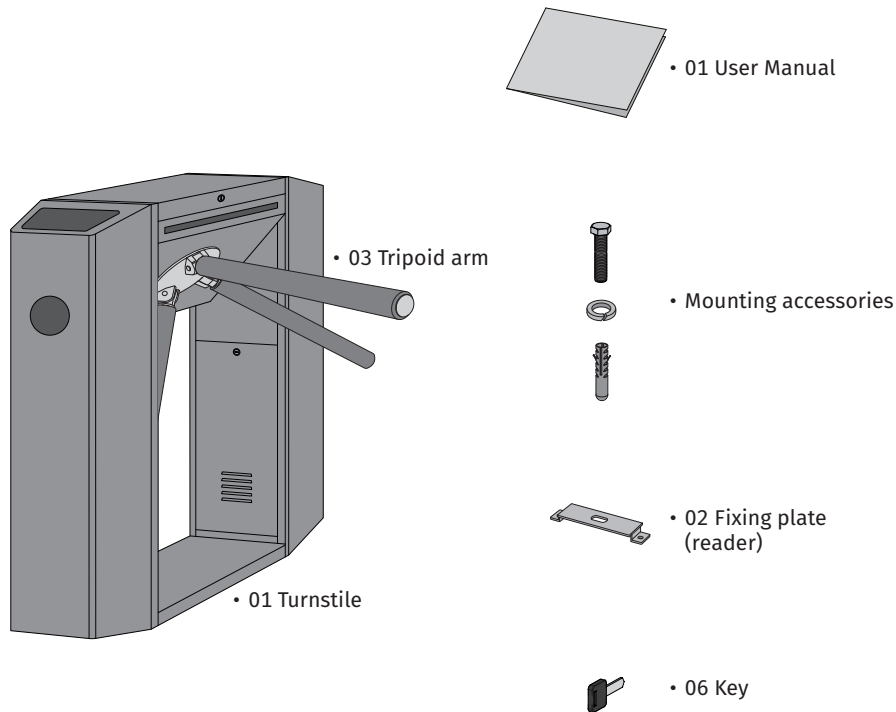

02. AUTOMATION

TECHNICAL CHARACTERISTICS

	MTT06
• Power supply	230 Vac
• Power	40W
• Frequency	50~60 Hz
• Passage width	520mm - 570mm
• Working temperature	-25°C ~ 55°C
• Mechanism	Electromagnetic
• IP	IP56
• Passages per minute	30 - 40 people / min

DIMENSIONS

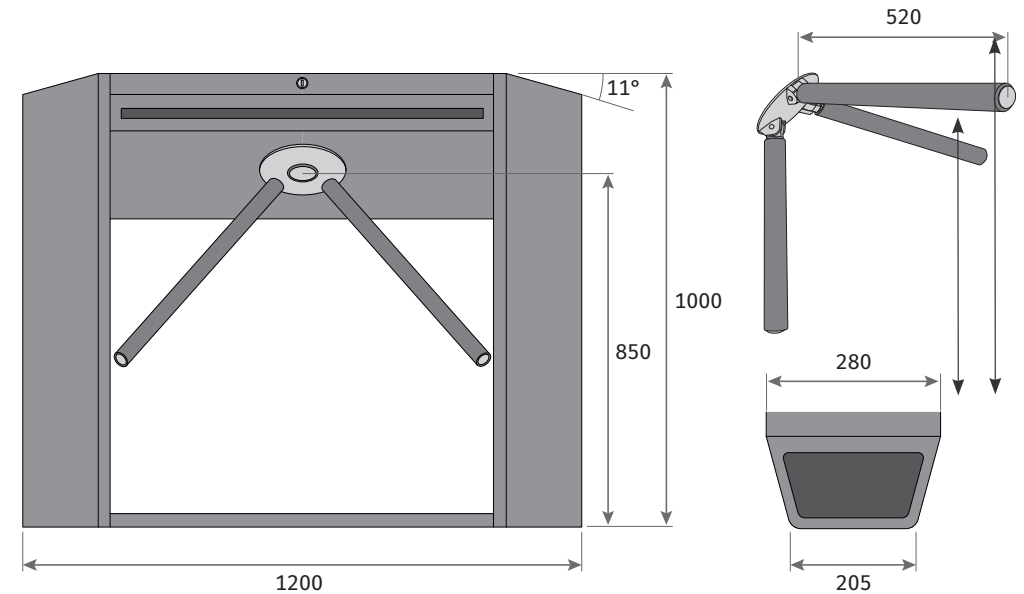

03. INSTALLATION

PRE-INSTALLATION

- Turnstile users must not open the mechanism. Maintenance and repair work should only be carried out by specialized personnel. Unconscious interventions can lead to dangerous situations for the mechanism and for the user
- Turnstiles must be protected against any type of shock and vibration.
- Do not insert any voltage beyond the values specified in the technical characteristics of the turnstile.
- Do not exceed the relative humidity and operating temperature values specified in the technical characteristics of the turnstile.
- Check all connections and verify that they are correct before supplying power to the turnstile.
- Do not use any equipment on the turnstile other than the hardware and parts provided by the producer.
- Disconnect the power supply in the event of an electrical failure in the turnstiles. Please contact the supplier directly without intervening in the product.
- Make sure the power was cut before proceeding to the maintenance / cleaning the turnstiles.
- The inside of the turnstile must not come into contact with water. Do not use the turnstile in high magnetic fields.
- The turnstile cannot be stored or operated in a humid environment.
- Do not continue to use your turnstile if it is damaged or defective. Contact us and inform the technical service of the product without delay.
- Do not allow children or unauthorized persons to play with the turnstile.

GROUND PREPARATION

- The floor on which the turnstiles are to be mounted must be completely flat and balanced.
- Installations should not be made if there are bumps and slopes on the floor.
- The assembly must not be done on unstable floors (example: soil, sand, gravel, plaster).
- There must not be installation or wiring under the floor where the tourniquet will be installed (If it is not possible to fulfill this requirement, the installation must be specified according to a project).
- No dust should enter the holes when mounting the turnstile on the floor.
- If possible, remove dust with a pneumatic hose or similar tools.

03. INSTALLATION

INSTALLATION

• INSTALL TURNSTILE

- 1 Remove the side door to access the interior of the structure.
- 2 Mark the drilling areas according to the holes in the bottom of the turnstile (on each side of the turnstile). Remove the turnstile and drill the soil.

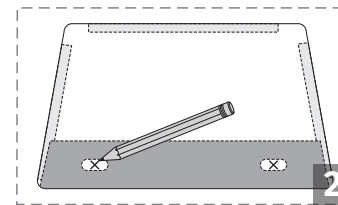

i The turnstile must be moved with the help of one person.

- 3 Place the turnstile at the installation site and pass the power cable (230V).
- 4 Insert the bushings (x4), nuts (x4) and screws (x4) into the holes. Tighten with a wrench.

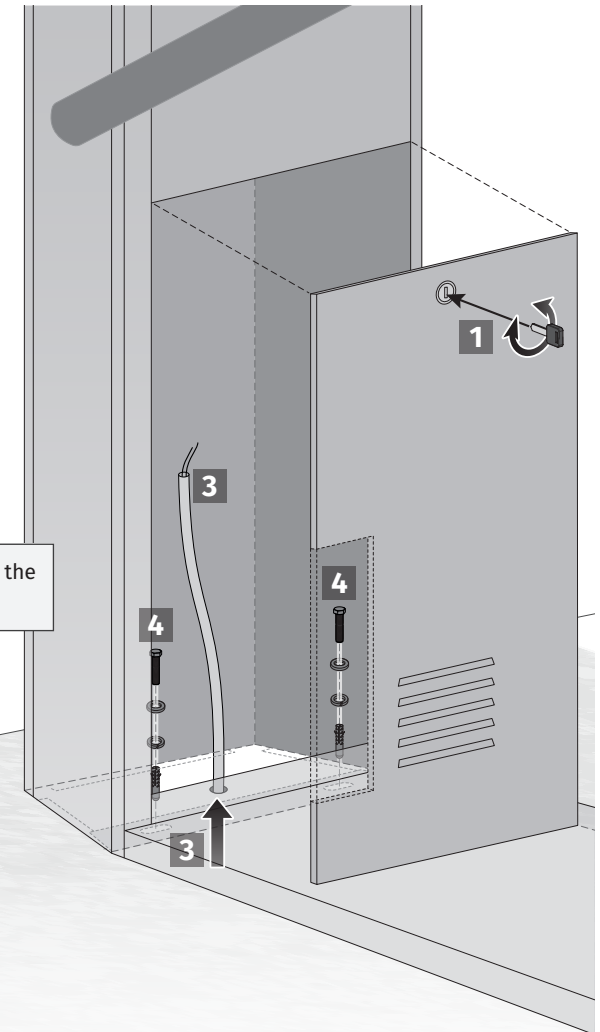
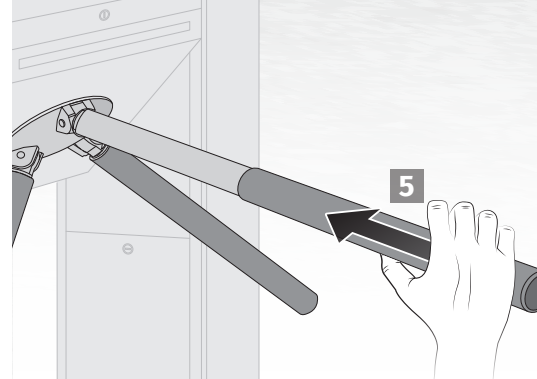

• APPLY SPONGES ON THE ARMS

- 5 Insert the protective sponges into each of the arms of the turnstile.

04. CONNECTIONS

DIAGRAM

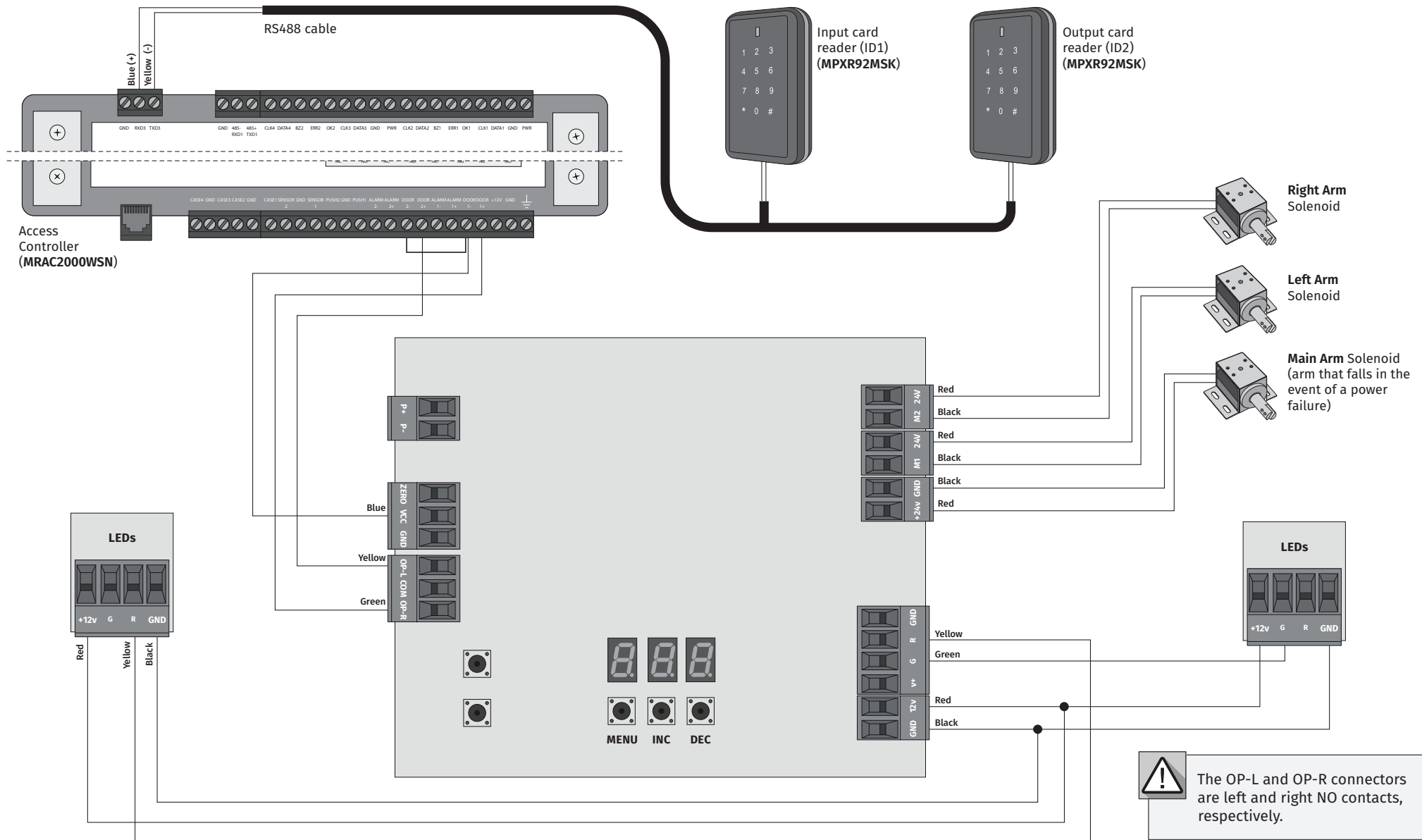

05. PROGRAMMING

NAVIGATION IN THE MENUS

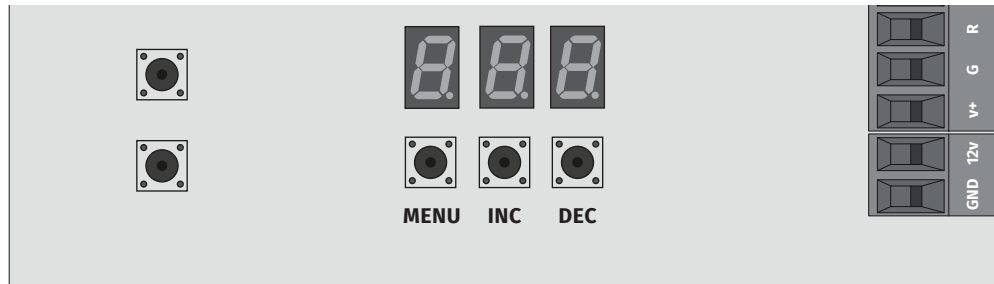

- 01 • To access the functions press the **MENU** for 1 second.
- 02 • Use **DEC** and **INC** to navigate between functions.
- 03 • Press **MENU** to enter the desired function.
- 04 • Use **DEC** and **INC** to choose the desired value for the function.
- 05 • Press **MENU** to save the value.



• After 5 seconds without button operation, it will automatically exit programming.

FUNCTIONS

MENU	FUNCTION	FACTORY VALUE	FACTORY VALUE	MINIMUM VALUE	MAXIMUM VALUE
F01	RELAY TIME ADJUSTMENT	It allows defining the time between the release of the arms (impulse to open) and the passage block. Value 1 = 1 second	005	000	030
F02	PASSAGE PERMISSIONS	000 • Right and left opening totally prohibited 001 • Both allowed 002 • Left opening prohibited, right opening allowed 003 • Right opening prohibited, left opening allowed	001	-	-
F03	OPERATION MODE	000 • Free passage 001 • Free passage when there is a power cut	001	-	-
F04	OCCUPANCY LIMIT	000 • Disabled 001 • Allows you to define a maximum occupancy number, blocking the passage if the space capacity is at the limit. (* Connection of an occupancy control system is required - Example: PORTER)	000	000	999

06. MAINTENANCE

MAINTENANCE



To make the maintenance of the turnstile, ensure that it is disconnected from the power supply.

- All external components of the turnstile (arms, box and body) must be cleaned regularly to ensure proper functioning.
- Acidic or basic chemicals should not be used on the turnstile sheet surface.
- All sheet metal surfaces must be cleaned with a stainless maintenance spray. If you do not have a spray with the characteristics indicated, contact your supplier for advice.
- The mechanism must be cleaned and lubricated periodically every six months. For this purpose, suitable lubricating grease must be used.
- The damper and brake settings of the mechanism must be checked and adjusted during maintenance.
- The interior must be cleaned regularly with a dry cloth and must not be exposed to dust.

07. TROUBLESHOOTING

FINAL CONSUMERS AND SPECIALIZED TECHNICIANS INSTRUCTIONS

Anomaly	Cause	Procedure
The turnstile arms do not lock, the LEDs are not working and the turnstile does not receive commands, even if there is power	<ul style="list-style-type: none"> The energy may not be enough The control board's power cable may be disconnected. The power supply may be defective. 	<ul style="list-style-type: none"> The power of the power supply must be checked with a multimeter. External and internal power cables must be checked manually.
There is energy in the turnstile, the LEDs are on, but the arms are stationary. The solenoids do not lock.	<ul style="list-style-type: none"> The brake solenoid cables may be disconnected. The access card may be defective. The solenoid locking pins may be overloaded. 	<ul style="list-style-type: none"> Check the connections between the control board and the solenoids. Measure the voltage values.
The LED lights are in the "green arrow" position, but the turnstile arms do not allow passage.	<ul style="list-style-type: none"> The solenoids may be defective. The solenoid springs may have been deformed and may not be able to pull the guides. The access card may be defective. 	<ul style="list-style-type: none"> If the solenoid is defective, it must be replaced. The solenoids must be cleaned with contact spray. If the springs are deformed, they must be replaced. If the access card is defective, it must be replaced.
The turnstile allows to pass but does not close after passing. It closes automatically after several passes.	<ul style="list-style-type: none"> Directional sensors may be defective. There may be poor contact when connecting the directional sensors. The access card may be defective. 	<ul style="list-style-type: none"> If the sensors are defective, they must be replaced. Check the cable terminals manually. If they are defective, they must be replaced. If the access card is defective, it must be replaced.
After passing, the arms remain crossed before reaching the center, or tap and stop audibly.	<ul style="list-style-type: none"> The damper may be out of adjustment. The damper may be defective. The damper bearing may be defective. 	<ul style="list-style-type: none"> The damper must be adjusted as described in the manual. If the damper is defective, it must be replaced. If the bearing is defective, it must be replaced.
The suspended arm does not fall even in an emergency.	<ul style="list-style-type: none"> The motor may be defective. Directional sensors may be defective. The drop pin may be stuck. 	<ul style="list-style-type: none"> If the engine is defective, it must be replaced. If the sensors are defective, they must be replaced. The drop pin must be cleaned and lubricated.
At the moment of passing, the arms remain locked, do not rotate or are difficult to rotate.	<ul style="list-style-type: none"> The spring may be damaged. A cable or an external element may be attached to the mechanism. The movement springs may not be working. 	<ul style="list-style-type: none"> If the spring is defective, it must be replaced. The turnstile must be switched off and not switched on again. Contact your authorized service. If the movement springs are deformed, they must be replaced.
When the suspended arm falls, it does not return to the starting position.	<ul style="list-style-type: none"> The arm pin may not fit the handle. The drop pin on the arm may be stuck. 	<ul style="list-style-type: none"> The arm drop pin must be cleaned with contact spray or similar materials. The mechanism must be lubricated with oil to facilitate the operation of the pin. If the problem is not resolved, the pin must be replaced.
The turnstile allows continuous passage in one direction only.	<ul style="list-style-type: none"> It may be running in unidirectional free mode. The solenoid cable or spring may be improperly connected. 	<ul style="list-style-type: none"> If there is a spring or cable not properly connected, connect correctly. If it doesn't work, they must be replaced.
The turnstile works correctly with all its functions, but the LEDs do not light.	<ul style="list-style-type: none"> LED boards or cables may be defective. The control board may be defective. 	<ul style="list-style-type: none"> If the LED board is defective, it must be replaced. If the LED cable is defective, it must be replaced. If the control board is defective, it must be replaced.